

# CATALOGUE GÉNÉRAL CATÁLOGO GENERAL MAIN CATALOGUE

Mobilier  
Mobiliario  
Furniture





# ENTERPRISE EMPRESA BUSINESS

---

**MOBEL LINEA, S.L.** est une entreprise familiale fondée en 1973 et située à Cervera (Lleida), Espagne.

Depuis le début, comme fabricants de mobilier de bureau, notre objectif a été de proposer des solutions simples, fonctionnelles, innovantes et de qualité pour transformer les espaces de travail en écosystèmes de productivité, de coexistence et de confort. La motivation constante à nous rapprocher des gens a eu un impact positif sur notre façon de travailler et de nous organiser en appliquant de nouvelles méthodologies et processus.

Au fil des années, nous avons acquis une notoriété dans le secteur et nous nous sommes imposés comme l'un des principaux fabricants de mobilier de bureau au niveau national et européen.

Malgré l'équipe de 280 personnes, nous continuons à garder vivante notre essence familiale.

**MOBEL LÍNEA, S.L.** somos una empresa familiar fundada en el año 1973 y situada en Cervera, provincia de Lérida (España).

Somos fabricantes de mobiliario de oficina, y desde los inicios, nuestro propósito ha sido ofrecer soluciones sencillas, funcionales, innovadoras y de calidad para transformar los espacios de trabajo en ecosistemas de productividad, convivencia y confort. Nuestra motivación constante por acercarnos a las personas ha impactado de forma positiva en nuestra forma de trabajar y de organizarnos aplicando nuevas metodologías y procesos.

Con el paso de los años hemos ido ganando notoriedad en el sector y nos hemos consolidado como uno de los fabricantes de muebles de oficina líder a nivel nacional y Europeo.

A pesar de contar con un total de 280 trabajadores, seguimos manteniendo viva nuestra esencia familiar.

**MOBEL LINEA, S.L.** is a family run business founded in 1973 and located in Cervera (Lleida), Spain.

As manufacturer of office furniture and seating, from the beginning, the aim has been to offer functional, innovative, and quality solutions to transform offices into spaces of productivity, collaboration, and well-being. The focus on people has a positive impact on the way Mobel Linea sees the future of working and organizing by applying new methodologies and processes.

Over the years the company has grown into an important player in the office furniture industry in Western Europe.

With a total of over 280 workers, Mobel Linea still maintains the family essence alive.



# RESSOURCES RECURSOS RESOURCES

Nos installations, comme l'équipe humaine de notre usine, se sont développées progressivement, en s'adaptant aux demandes et besoins du marché. En 1995, la production de l'usine a été divisée en deux entrepôts, l'un pour bois et l'autre pour le métal:

- MOBEL I: Entrepôt principal, d'une surface de 45.000 m<sup>2</sup>, destiné à la fabrication de mobilier et sièges.
- MOBEL III: situé dans la zone industrielle et d'une surface de 13.000 m<sup>2</sup>, il est destiné à la fabrication de composants, structures et armoires métalliques.

Notre production est gérée par une unité logistique novatrice depuis la création d'un entrepôt en 2004 entièrement automatisé et auto-portant avec une capacité de 33.000 europalettes. D'une hauteur de 41 mètres ce entrepôt est un point de référence sur le territoire.

Déjà en 2011, création d'une annexe de l'autre usine située dans la zone industrielle pour la fabrication des armoires métalliques. À cette époque, nous avons profité de l'intervention pour remplacer le tunnel de peinture par un tunnel beaucoup plus performant et écoresponsable.

Actuellement, nous nous engageons à accroître notre capacité de production en investissant dans une nouvelle ligne de fabrication de 2.000 m<sup>2</sup> avec laquelle nous atteindrons une plus grande capacité de production, une meilleure automatisation, une meilleure qualité de nos produits ainsi qu'une considérable réduction de la consommation énergétique.

Nuestras instalaciones, al igual que el equipo humano, han ido creciendo de forma progresiva adaptándose a las demandas del mercado. En 1995 se dividió la producción de la fábrica en dos naves, una para la madera y otra para el metal:

- MOBEL I: Nave principal, con una superficie de 45.000 m<sup>2</sup>, destinada a la producción de mobiliario de madera y sillería.
- MOBEL III: ubicada en el polígono industrial y con una superficie de 13.000 m<sup>2</sup> está destinada a la fabricación de estructuras y muebles metálicos.

En 2004 construimos un almacén automatizado que supuso la trazabilidad absoluta de la producción de la fábrica. El almacén destaca por su dimensiones, 41 metros de altura y una capacidad de hasta 33.000 europalets, y lo convierte en un punto de referencia en el territorio.

Ya en 2011, ampliamos la nave situada en el polígono industrial con el fin de fabricar armoires metálicos. En ese momento, aprovechamos la intervención para sustituir el túnel de pintura por otro mucho más eficiente y responsable con el Medio Ambiente.

En la actualidad, apostamos por ampliar nuestra capacidad productiva invirtiendo en un nuevo tren de producción de 2.000 m<sup>2</sup> con el que lograremos: mayor capacidad de producción, mayor automatización entre procesos, mayor calidad en nuestros productos y menor consumo energético.

Mobel Linea has been growing progressively, adapting to market demands. In 1995 the factory opened a second facility for metal production, so nowadays Mobel Linea's production takes place in:

- MOBEL I: Main facilities, with an area of 45,000 m<sup>2</sup>, headquarters and where production of wooden furniture and chairs finds place.
- MOBEL III: located in the nearby industrial estate, with 13,000 m<sup>2</sup>, is the place for the manufacture of metal cabinets, frames, and other metal parts.

In 2004 an all-automated warehouse was built for raw materials, stocks, and finished products. The warehouse stands out for its big dimensions, is 41 meters high and has a capacity of up to 33,000 Euro pallets, making it a point of reference in the landscape of Cervera.

In 2011, MOBEL III expanded to produce metal cabinets and the installation of a brand-new painting tunnel meeting the latest requirements in terms of efficiency and the environment.

This year, we invested in a new 2,000 m<sup>2</sup> production plant with which we are achieving: higher production capacity, better automation between processes, lower energy consumption and improving product quality.

CROISSANCE CONSTANTE

CRECIENDO DE FORMA  
CONSTANTE

STEADY GROWTH



# QUALITÉ CALIDAD QUALITY

La satisfaction client est inscrite dans notre ADN, c'est pourquoi nous veillons jour après jour à la qualité de tous nos produits.

Depuis 2001, nous sommes certifiés conformément aux normes de gestion de la qualité établies dans la norme **ISO 9001**. Essentiellement, avec cette norme, nous garantissons que tous les processus visent l'efficacité du système de gestion et l'assurance qualité de nos produits et services. De plus, le lien implicite entre **ISO 9001**, **ISO 14001**, **ISO 14006** et PEFC nous permet de réaliser un système de management intégré axé sur le management environnemental.

Nos produits sont de haute qualité et ils bénéficient du tampon qualité contrôlée après avoir été soumis à des tests rigoureux de sécurité et de durabilité par le laboratoire de l'institut technologique du meuble, bois, emballages et autres, **AIDIMME**.

La satisfacción de los clientes está inscrita en nuestro ADN, por eso velamos día tras día por la calidad de todos nuestros productos.

Desde el año 2001 estamos certificados de acuerdo con los estándares de gestión de calidad establecidos en la norma **ISO 9001**. En esencia, con esta norma, garantizamos que todos los procesos están orientados a la eficacia del sistema de gestión y al aseguramiento de la calidad de nuestros productos y servicios. Adicionalmente, la vinculación implícita entre la **ISO 9001**, la **ISO 14001**, la **ISO 14006** y el PEFC nos permite llevar a cabo un sistema de gestión integrado incidiendo en la gestión ambiental.

Fabricamos productos de alta calidad y por eso nuestros muebles llevan el sello de calidad tras ser sometidos a rigurosas pruebas de seguridad y durabilidad en el laboratorio **AIDIMME**, Instituto Tecnológico Metalmeccánico, Mueble, Madera, Embalaje y Afines.

Customer satisfaction is very important for Mobel Linea, which is why the quality of all the products are ensured day after day.

Since 2001 Mobel Linea has been certified in accordance with the quality management standards established in the **ISO 9001** standard. In essence, with this standard, it guarantees that all processes are aimed at the effectiveness of the management system and the quality assurance of their products and services. Additionally, the implicit link between **ISO 9001**, **ISO 14001**, **ISO 14006** and PEFC allows to carry out an integrated management system focusing on environmental management.

Manufacturing high-quality products and is why the furniture bears the seal of quality after being subjected to rigorous safety and durability tests in the **AIDIMME** laboratory, Technological Institute for Metalworking, Furniture, Wood, Packaging and Related.

# RÉSEAU COMMERCIAL RED COMERCIAL COMMERCIAL NETWORK

Grâce à notre réseau commercial de revendeurs, **MOBEL LINEA**, S.L. est présente dans différents pays du monde. Nos principaux marchés sont concentrés principalement en Europe (France, Allemagne, Royaume-Uni, la Suisse, la Belgique, la Hollande, Bulgarie, Portugal, Grèce, etc.), mais nous avons également des points stratégiques hors d'Europe (Émirats Arabes, Arabie Saoudite, Qatar, Costa Rica, etc.).

Grâce à notre flotte de 35 camions et 18 remorques, nous sommes en mesure de réaliser des livraisons à tous nos clients européens, garantissant ainsi les délais de livraison demandés et permettant même de les réduire en cas d'extrême priorité.

En plus de nos camions, nous utilisons le transport maritime pour le commerce international par le biais de containers ou groupages, travaillant avec les principales entreprises d'affrètement et obtenant un maximum de garantie de fiabilité, qualité et sécurité de la bonne arrivée de nos produits à destination.

Gracias a nuestra red comercial de representantes y distribuidores, **MOBEL LINEA**, S.L. está presente en distintos países del mundo. Nuestro nicho de mercado se concentra, en su mayoría, en Europa (Francia, Alemania, Reino Unido, Suiza, Bélgica, Bulgaria, Portugal, Grecia, etc.), pero también tenemos puntos estratégicos fuera de Europa (Emiratos Árabes, Arabia Saudí, Qatar, Costa Rica, etc.).

Disponemos de una flota de 35 camiones y 18 remolques, con los que garantizamos las entregas a todos nuestros clientes europeos, cumpliendo con los plazos de entrega exigidos e incluso reduciéndose en casos de extrema prioridad.

Además de nuestros camiones, para el Comercio Internacional, utilizamos el transporte marítimo, con contenedores o grupajes, trabajando con las principales compañías navieras del mercado y obteniendo las máximas garantías de fiabilidad, calidad y seguridad en la llegada de nuestros productos a destino.

Thanks to a network of representatives and distributors, **MOBEL LINEA**, S.L. is present in numerous countries around the world. The main market is in Western Europe (France, Portugal, Belgium, The Netherlands, United Kingdom, Germany and Switzerland), but also sells in Eastern Europe, the Middle East, South America and several African Countries.

Mobel Linea has its own fleet of 35 trucks to deliver European customers, being able to guarantee fast deliveries and reduce product-damage due to transport.

For overseas deliveries Mobel Linea works with well-known shipping companies to obtain the maximum guarantees of reliability, quality and safety in the transport of the products.



GARANTIE DE QUALITÉ  
ET SATISFACTION

ASEGURAMOS CALIDAD Y  
SATISFACCIÓN

QUALITY AND SATISFACTION  
GUARANTEE

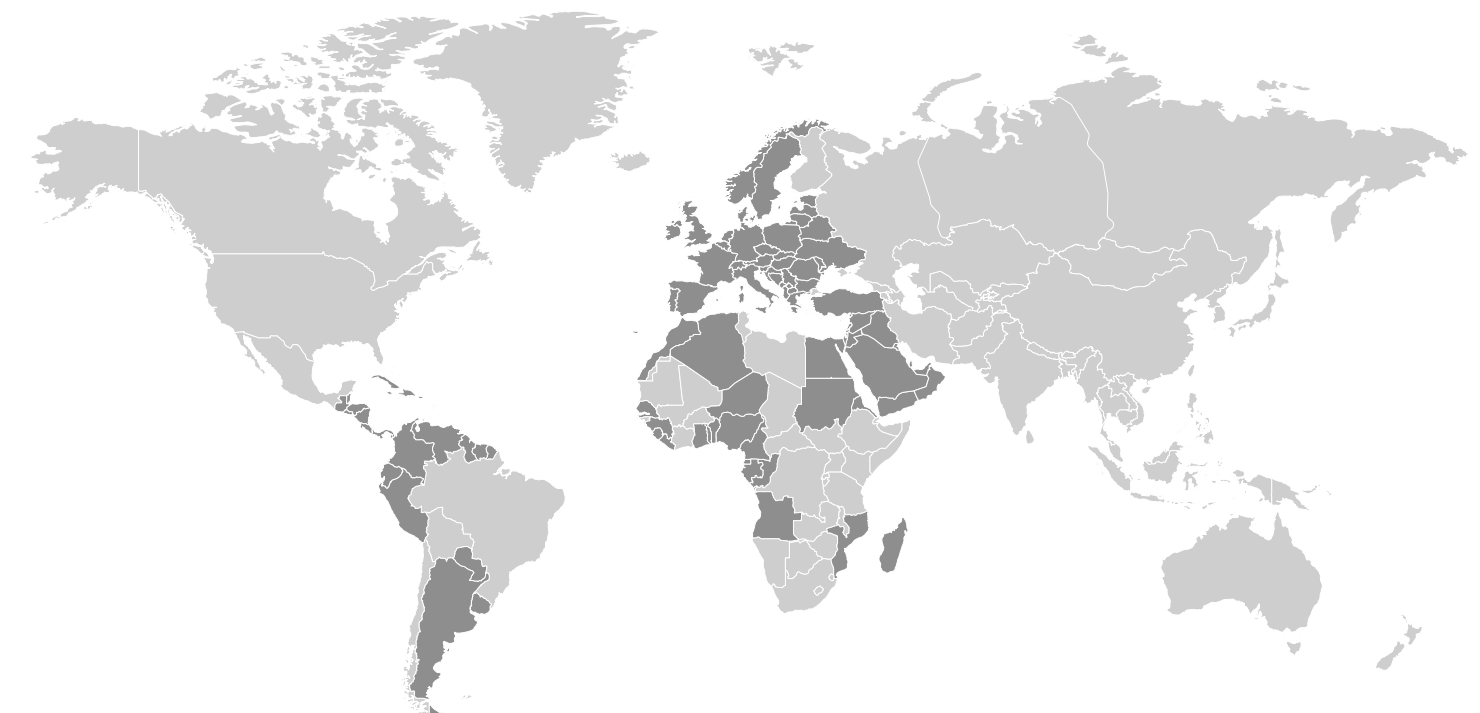

Zones d'implantations **MOBEL LINEA**.  
Zonas donde actualmente está presente **MOBEL LINEA**, S.L.  
States with **MOBEL LINEA**, S.L. Partners.

# INVESTISSEMENT ET DÉVELOPPEMENT INVESTIGACIÓN Y DESARROLLO RESEARCH AND DEVELOPMENT

En tant que concepteurs-designers et fabricants de mobilier de bureau, nous répondons aux besoins du marché en apportant valeur et professionnalisme. Nous créons des produits axés sur les besoins des gens. Nous analysons leur comportement en tenant compte de l'évolution technologique et des méthodologies de travail afin de le transformer en bureau.

Dans le processus de conception et de développement, nous sommes soutenus et guidés par les prémisses de l'**Écodesign**, réduisant l'impact environnemental de nos produits tout au long de leur cycle de vie en appliquant différentes stratégies:

- Utilisation de matériaux recyclables.
- Bois issu de sources durables: certification **PEFC**.
- Réduire l'impact environnemental du transport et des déchets d'emballage générés.
- Garantir le moindre impact environnemental lors de l'utilisation.
- Tenir compte du tri et de la haute recyclabilité des composants en fin de vie.

Notre proposition de valeur se concentre sur l'intemporalité du design, offrant fonctionnalité, confort et durabilité à nos clients. Le temps et la confiance nous motivent à avancer et à continuer à apporter de l'expérience et de l'innovation.

Como diseñadores y fabricantes de mobiliario de oficina atendemos a las necesidades del mercado aportando valor y profesionalidad. Creamos productos poniendo el foco en las necesidades de las personas. Analizamos sus comportamientos fijándonos en la evolución tecnológica y las metodologías de trabajo para detectar oportunidades y transformar su experiencia en la oficina.

En el proceso de concepción y desarrollo nos apoyamos y guiamos por las premisas del **Ecodiseño**, reduciendo el impacto ambiental de nuestros productos a lo largo de su ciclo de vida aplicando diferentes estrategias:

- Uso de materiales reciclables.
- Madera procedente de fuentes sostenibles: certificación **PEFC**.
- Reducir el impacto ambiental del transporte y de los residuos generados de embalajes.
- Asegurar el menor impacto ambiental durante el uso.
- Tener en cuenta la separación y la alta reciclabilidad de los componentes al final de su vida útil.

Nuestra propuesta de valor se centra en la atemporalidad del diseño aportando funcionalidad, comodidad y durabilidad a nuestros clientes. El tiempo y la confianza han estimulado nuestras ganas y nuestra motivación para seguir escalando peldaños en el mercado brindando experiencia e innovación.

As designers and manufacturers of office furniture, the needs of the market are served, providing value and professionalism, and always focusing on the needs of people. Analysing their behaviour by looking at technological evolution and work methodologies to detect opportunities and so transform the people's experience in the office.

In the process of conception and development, supporting and guiding by the premises of **Eco-design**, reducing the environmental impact of all the products throughout their life cycle by applying different strategies:

- Use of recyclable materials.
- Wood from sustainable sources: **PEFC** certification.
- Reduce the environmental impact of transport and packaging waste generated.
- Ensure the least environmental impact during use.
- Consider the separation and high recyclability of the components at the end of their useful life.

Mobel Linea's value proposition focus on the timelessness of design, providing functionality, comfort, and durability to the customers. Time and trust have stimulated Mobel Linea's desire and motivation to continue climbing steps in the market, providing experience and innovation.

| ÉCOCONCEPTION

| ECODISEÑO

| ECODESIGN

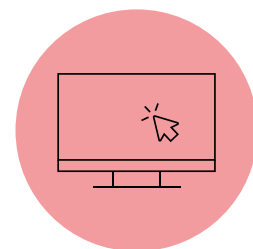

RECHERCHE  
INVESTIGACIÓN  
RESEARCH



DÉVELOPPEMENT  
DESARROLLO  
DEVELOPMENT

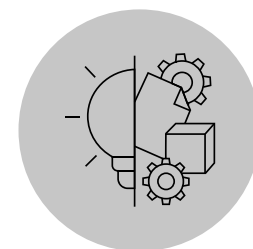

INNOVATION  
INNOVACIÓN  
INNOVATION



# ENVIRONNEMENT MEDIO AMBIENTE ENVIRONMENT

Notre engagement envers l'environnement est rigoureux et transparent. Chez Mobel Linea nous appliquons un système de gestion durable aux produits et aux installations qui est essentiel pour réduire l'impact environnemental. La durabilité et l'environnement représentent une responsabilité pour chacun.

En 2005, nous avons intégré la norme **ISO 14001** en Systèmes de Gestion Environnementale qui nous certifie en tant qu'entreprise respectueuse de l'environnement et garantit un travail actif dans l'amélioration continue de nos processus de fabrication.

Notre principale matière première est l'aggloméré de particules en bois avec un traitement spécial superficiel de résines mélaminiques. La certification **PEFC** atteste de notre engagement avec l'Environnement.

La gestion durable commence dès la conception du produit. Pour cette raison, depuis 2013, chez MOBEL LINEA nous avons mis en place la norme **ISO 14006** qui permet d'intégrer un Système de Gestion Environnementale d'**Ecodesign**. Ainsi, lorsque nous concevons un nouveau produit, nous considérons l'impact environnemental qu'il peut avoir dans toutes les phases de son cycle de vie et nous essayons de le réduire sans altérer la qualité de ce produit.

Nuestro compromiso con el medio ambiente es riguroso y transparente. En Mobel Linea aplicamos un sistema de gestión sostenible a los productos e instalaciones que es esencial para reducir el impacto ambiental. La sostenibilidad y el medio ambiente representan una responsabilidad para todos.

En 2005 integramos la normativa **ISO 14001** en Sistemas de Gestión Ambiental que nos certifica como empresa respetuosa con el medio ambiente y garantiza el trabajo activo en mejora continua de nuestros procesos de fabricación.

Una de nuestras materias primas es el aglomerado de partículas de madera con un tratamiento superficial de resinas melamínicas. La certificación **PEFC** que recibe el producto certifica nuestro compromiso con el Medio Ambiente.

La gestión sostenible empieza en el diseño. Por eso, desde el año 2013, en Mobel Linea implementamos la norma **ISO 14006** que permite implantar un sistema de gestión ambiental de **Ecodiseño**. Así pues, cuando proyectamos un nuevo producto contemplamos el impacto ambiental que puede tener en todas las fases de su ciclo de vida y tratamos de reducirlo sin afectar la calidad de dicho producto.

Commitment to the environment is rigorous and transparent. Mobel Linea applies a sustainable management system that is essential to reduce the environmental impact. Sustainability and the environment represent a responsibility for everyone.

Since 2005 the **ISO 14001** standard certifies Mobel Linea as a company that respects the environment and guarantees active work in continuous improvement of its manufacturing processes.

One of the raw materials is the agglomerate of wood particles with a surface treatment of melamine resins. The **PEFC** certification of this raw material certifies the commitment to the Environment.

Sustainable management begins in the design. For this reason, since 2013, Mobel Linea implements the **ISO 14006** standard that allows an **Eco-design** environmental management system. Thus, when a new product is designed, the environmental impact that it may have in all phases of its life cycle is considered and reduced without affecting the quality of the product.

## | DURABILITÉ | SOSTENIBILIDAD | SUSTAINABILITY



**Matériaux recyclables.**  
Materiales reciclables.  
Recyclable materials.



**Optimisation des emballages.**  
Optimización de embalaje.  
Packaging optimization.



**Bois issu de sources durables.**  
Madera de fuentes sostenibles.  
Wood from sustainable sources.



**Recyclabilité en fin de vie utile.**  
Reciclabilidad al final de vida útil.  
Recyclability at the end of its useful life.



PEFC  
PEFC/14-35-00142

MOBILIER  
MOBILIARIO  
FURNITURE

INDEX

RÉGLABLES  
REGULABLES  
ADJUSTABLE HEIGHT 016

TABLES BASSES  
MESAS DE CENTRO  
COFFEE TABLES 262

MOBILIER MODULAIRE  
INSTALACIONES  
DESK SYSTEMS 042

CLOISONS  
MAMPARAS  
SCREENS 294

OPÉRATIF  
OPERATIVAS  
INDIVIDUAL DESKS 106

COLLECTIVITÉS  
COLECTIVIDADES  
MULTI-PURPOSE TABLES 340

DIRECTION  
DIRECCIÓN  
EXECUTIVE DESK 144

ACCUEIL  
RECEPCIÓN  
RECEPTION 372

TABLES HAUTES  
MESAS ALTAS  
HIGH TABLES 166

RANGEMENT  
ALMACENAJE  
STORAGE 404

TABLES DE RÉUNION  
MESAS DE REUNIÓN  
MEETING TABLES 208



FINITIONS

Acabados  
Finishes

464 | TISSU / TAPIZADOS / UPHOLSTERY



RÉGLABLES  
REGULABLES  
ADJUSTABLE HEIGHT



**018** | UP



**030** | TRAM

# Up

Cette gamme de bureaux opératifs au design contemporain et futuriste existe en deux versions: fixe ou réglable. La version réglable électriquement permet d'ajuster la hauteur au besoin de l'utilisateur.

Mesa operativa con un diseño moderno y futurista. Hay dos modelos a escoger: la fija o la elevable. La mesa elevable dispone de un sistema eléctrico que permite adaptar la altura de la mesa según las necesidades del usuario.

This office table has a modern and futurist look. There are two options: fixed or height adjustable frame. Each user can choose its favorite table height lifting the desk with an electric engine.

#### PLATEAU / SOBRE / DESK TOP

Mélamine / Melamina / Melamine: 25 mm  
Stratifié / Estratificado / Stratified:  
Phénolique / Fenólico / Phenolic: 13 mm

Chant en ABS / Canto ABS / ABS edges

#### STRUCTURE / ESTRUCTURA / FRAME

Acier:  
Acero: 70 x 70 x 2 mm  
Steel:



#### FINITION STRUCTURE / ACABADO ESTRUCTURA / FRAME FINISH

Peinture époxy  
Pintura epoxi  
Epoxy paint

#### HAUTEUR / ALTURA / HEIGHT

65 cm < 130 cm

#### OPTION / OPCIÓN / OPTION

Voile de fond / Faldón / Modesty panel  
Goulotte / Bandeja electrificación / Cable tray  
Support écran / Soporte pantalla / Monitor holder  
Cloisonnettes / Plafones / Screens

ENSEMBLE DE  
BUREAUX RÉGLABLES  
EN HAUTEUR

CONJUNTO  
DE MESAS  
ELEVABLES

HEIGHT ADJUSTABLE  
FACE TO FACE  
DESKS

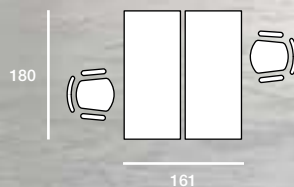

BUREAUX À  
HAUTEUR FIXE  
AVEC FORME

MESA  
FIJA CON  
FORMA

FIXED HEIGHT  
DESK WITH  
SHAPE

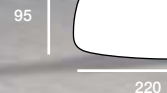

BUREAUX À  
HAUTEUR FIXE  
AVEC CRÉDENCE

MESA FIJA  
INDIVIDUAL  
CON CREDENCIA

FIXED HEIGHT  
DESK WITH  
SIDE CREDENZA

Combinable avec caissons et crédences.  
Combinable con cajoneras y credencias.  
Combine with pedestals and credenzas.

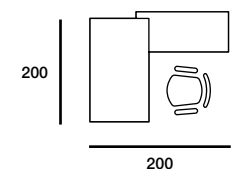

BUREAUX EN VIS  
À VIS RÉGLABLES  
EN HAUTEUR

MESAS  
ENFRENTADAS  
ELEVABLES

HEIGHT ADJUSTABLE  
FACE TO FACE  
DESKS





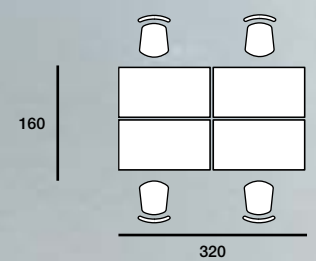



Plateau coulissant sur 14 cm.  
El sobre puede deslizarse 14 cm.  
Sliding top 14 cm.

















# MODÈLES | VARIANTES | VERSIONS

RÉGLABLE EN HAUTEUR / REGULABLE EN ALTURA / ADJUSTABLE HEIGHT

MODÈLE / VARIANTES / VERSIONS	DIMENSIONS / MEDIDAS / MEASUREMENTS	RÉFÉRENCE / REFERENCIA / CODE			
 Bureau individuel Mesa rectangular Rectangular desk	220 x 80 cm 200 x 80 cm 180 x 80 cm 160 x 80 cm 140 x 80 cm	591.100... 591.101... 591.102... 591.103... 591.104...	591.200... 591.201... 591.202... 591.203... 591.204...	591.300... 591.301... 591.302... 591.303... 591.304...	
 Bureau individuel avec forme Mesa con forma Shaped executive table	220 x 102,5 cm 200 x 102,5 cm	591.130... 591.131...	591.230... 591.231...	591.330... 591.331...	
 Bureau 120° Mesa 120° 120° desk	120°	591.110...	591.210...	591.310...	
 Bureaux en vis à vis Mesas enfrentadas Face to face desks	180 x 164 cm 160 x 164 cm 140 x 164 cm	591.120... 591.121... 591.122...	591.220... 591.221... 591.222...	591.320... 591.321... 591.322...	
 Type de boîtier réglage hauteur pour chaque plateau Controlador digital para cada sobre Digital display for each desk top	UP & DOWN	ES DE FR 1.591.058.000	CH 1.591.060.000	US 1.591.059.000	UK 1.591.057.000
 BOÎTIER MÉMOIRE / PROGRAMMABLE / PROGRAMMABLE		1.591.062.000	1.591.064.000	1.591.063.000	1.591.061.000







# FINITIONS | ACABADOS | FINISHES

STRUCTURE / ESTRUCTURA / FRAME | PLATEAU / SOBRE / DESKTOP



 Argent Plata Silver RAL 9006	 Blanc Blanco White RAL 9016	 Gris Gris Grey	 Hêtre Haya Beech	 Chêne Moyen Roble Maple
 Blanc Blanco White RAL 9016	 Poirier Peral Pear	 Wengué Wengue Wengue	 Acacia Clair Acacia Clara Light Acacia	 Acacia Foncé Acacia Oscura Dark Acacia
 Graphite Grafito Graphite RAL 7022	 Graphite Grafito Graphite	 Chêne Veiné Castaño Claro Oak	 Chêne Gris Castaño Oscuro Dark Oak	

# MODÈLES | VARIANTES | VERSIONS

HAUTEUR FIXE / FIJAS / FIXED HEIGHT















MODÈLE / VARIANTES / VERSIONS	DIMENSIONS / MEDIDAS / MEASUREMENTS	RÉFÉRENCE / REFERENCIA / CODE		
 Bureau individuel Mesa rectangular Rectangular desk	220 x 80 cm 200 x 80 cm 180 x 80 cm 160 x 80 cm 140 x 80 cm	591.140... 591.141... 591.150... 591.151... 591.152...	591.240... 591.241... 591.250... 591.251... 591.252...	591.340... 591.341... 591.350... 591.351... 591.352...
 Bureau rectangulaire pour crédence Mesa rectangular con credencia Executive table with side credenza	200 x 80 cm	591.142...	591.242...	591.342...
 Bureau individuel avec forme Mesa con forma Shaped executive table	220 x 102,5 cm 200 x 102,5 cm	591.160... 591.161...	591.260... 591.261...	591.360... 591.361...
 Bureau avec forme pour crédence Mesa con forma con credencia Shaped executive table with side credenza	200 x 102,5 cm	591.162...	591.262...	591.362...
 Bureau 120° Mesa 120° 120° desk	120°	591.153...	591.253...	591.353...
 Bureaux en vis à vis Mesas enfrentadas Face to face desks	180 x 164 cm 160 x 164 cm 140 x 164 cm	591.154... 591.155... 591.156...	591.254... 591.255... 591.256...	591.354... 591.355... 591.356...

# | COMPLÉMENTS | COMPLEMENTOS | COMPLEMENTS



MODÈLE / VARIANTES / VERSIONS	DIMENSIONS / MEDIDAS / MEASUREMENTS		RÉFÉRENCE / REFERENCIA / CODE		
	À droite / Derecha / Right	100 x 60 cm	591.170.-.-	591.270.-.-	591.370.-.-
		80 x 60 cm	591.172.-.-	591.272.-.-	591.372.-.-
<b>Retour secrétaire Ala taquígrafa Return</b>	À gauche / Izquierda / Left	100 x 60 cm	591.171.-.-	591.271.-.-	591.371.-.-
		80 x 60 cm	591.173.-.-	591.273.-.-	591.373.-.-
		100 x 60 cm	591.174.-.-	591.274.-.-	591.374.-.-
<b>Bureau secrétaire Mesa taquígrafa Shorthand desk</b>					
Monochrome / Monocolor / Single-colour					
	À droite / Derecha / Right	Prof./ Depth, 54,2 cm	1 porte coulissante / 1 puerta corredera / Sliding door		
		L. 200 H. 56,2 cm L. 150 H. 56,2 cm	562.101.-.-	562.105.-.-	
	À gauche / Izquierda / Left	L. 200 H. 56,2 cm L. 150 H. 56,2 cm	562.102.-.-	562.106.-.-	
		2 portes coulissantes / 2 puertas correderas / Sliding doors			562.103.-.-
<b>Crédence fixe avec portes coulissantes Credencia con puertas correderas Side credenza with sliding doors</b>	À droite / Derecha / Right	L. 200 H. 56,2 cm L. 150 H. 56,2 cm	562.104.-.-	562.108.-.-	
		À gauche / Izquierda / Left	L. 200 H. 56,2 cm L. 150 H. 56,2 cm	562.105.-.-	562.109.-.-

# | FINITIONS | ACABADOS | FINISHES

## STRUCTURE / ESTRUCTURA / FRAME | PLATEAU / SOBRE / DESKTOP

 Argent Plata Silver RAL 9006	 Blanc Blanco White	 Gris Gris Grey	 Hêtre Haya Beech	 Chêne Moyen Roble Maple
 Blanc Blanco White RAL 9016	 Poirier Peral Pear	 Wengué Wengue Wengue	 Acacia Clair Acacia Clara Light Acacia	 Acacia Foncé Acacia Oscura Dark Acacia
 Graphite Grafito Graphite RAL 7022	 Graphite Grafito Graphite	 Chêne Veiné Castaño Claro Oak	 Chêne Grisé Castaño Oscuro Dark Oak	
Monochrome Monocolor Single-colour				

# | COMPLÉMENTS | COMPLEMENTOS | COMPLEMENTS

MODÈLE / VARIANTES / VERSIONS	TYPE / TIPO / TYPE	DIMENSIONS / MEDIDAS / MEASUREMENTS	RÉFÉRENCE / REFERENCIA / CODE		
	Mélamine / Melamina / Melamine	220 cm	591.601.051	591.601.053	591.601.007
		200 cm	591.602.051	591.602.053	591.602.007
		180 cm	591.603.051	591.603.053	591.603.007
		160 cm	591.604.051	591.604.053	591.604.007
		140 cm	591.605.051	591.605.053	591.605.007
		120°	591.606.051	591.606.053	591.606.007
<b>Voiles de fond Faldones Modesty panels</b>		Retour secrétaire / Ala taquígrafa / Return	591.607.051	591.607.053	591.607.007
	Métal / Metal / Metal	220 cm	591.651.111	591.651.108	591.651.107
		200 cm	591.652.111	591.652.108	591.652.107
		180 cm	591.653.111	591.653.108	591.653.107
		160 cm	591.654.111	591.654.108	591.654.107
		140 cm	591.655.111	591.655.108	591.655.107
		120°	591.656.111	591.656.108	591.656.107
<b>Goulotte Bandeja electrificación Cable tray</b>		Retour secrétaire / Ala taquígrafa / Return	591.657.111	591.657.108	591.657.107
	Individuel / Individual / Single	220 cm	1.596.003.111	1.596.003.108	1.596.003.107
		200 cm	1.596.004.111	1.596.004.108	1.596.004.107
	Double / Doble / Double	180 cm	1.596.005.111	1.596.005.108	1.596.005.107
		160 cm	1.596.006.111	1.596.006.108	1.596.006.107
<b>Support écran Soporte pantalla Monitor holder</b>	Double / Doble / Double	140 cm	1.596.007.111	1.596.007.108	1.596.007.107
		120°	1.596.008.111	1.596.008.108	1.596.008.107

# | FINITIONS | ACABADOS | FINISHES



## STRUCTURE / ESTRUCTURA / FRAME

 Argent Plata Silver RAL 9006	 Blanc Blanco White RAL 9016	 Graphite Grafito Graphite RAL 7022
---	--	---



# CLOISONNETTES FRONTALES | PLAFONES | FRONT SCREENS

1 NIVEAU / 1 NIVEL / 1 LEVEL

2 NIVEAUX / 2 NIVELES / 2 LEVELS

MODÈLE / VARIANTES / VERSIONS	L.	RÉFÉRENCE / REFERENCIA / CODE
		   RAL 9006 RAL 9016 RAL 7022
Indiv. / Individ. / Single		
180 cm		386.008.--- 386.108.--- 386.208.---
160 cm		386.009.--- 386.109.--- 386.209.---
140 cm		386.010.--- 386.110.--- 386.210.---
Vis à vis / Enfrentadas / Face to face		
180 cm		596.110.--- 596.210.--- 596.310.---
160 cm		596.111.--- 596.211.--- 596.311.---
140 cm		596.112.--- 596.212.--- 596.312.---
120°		386.012.--- 386.112.--- 386.212.---

Mélamine  
Melamina  
Melamine

MODÈLE / VARIANTES / VERSIONS	L.	RÉFÉRENCE / REFERENCIA / CODE
		   RAL 9006 RAL 9016 RAL 7022
Indiv. / Individ. / Single		
180 cm		386.021.--- 386.121.--- 386.221.---
160 cm		386.022.--- 386.122.--- 386.222.---
140 cm		386.023.--- 386.123.--- 386.223.---
Vis à vis / Enfrentadas / Face to face		
180 cm		596.120.--- 596.220.--- 596.320.---
160 cm		596.121.--- 596.221.--- 596.321.---
140 cm		596.122.--- 596.222.--- 596.322.---
120°		386.025.--- 386.125.--- 386.225.---

Mélamine  
Melamina  
Melamine

FINITIONS  
ACABADOS  
FINISHES

007	Graphite Grafito Graphite	051	Argent Plata Silver
053	Blanc Blanco White	054	Gris Gris Grey
055	Hêtre Haya Beech	061	Chêne Moyen Roble Maple
062	Poirier Peral Pear	116	Wengué Wengue Wengue
103	Acacia Clair Acacia Clara Light Acacia	104	Acacia Foncé Acacia Oscura Dark Acacia
272	Chêne Veiné Castaño Claro Oak	273	Chêne Grisé Castaño Oscuro Dark Oak

FINITIONS  
ACABADOS  
FINISHES

204	Graphite Grafito Graphite	088	Argent Plata Silver
081	Blanc Blanco White	197	Gris Gris Grey
198	Hêtre Haya Beech	199	Chêne Moyen Roble Maple
200	Poirier Peral Pear	202	Wengué Wengue Wengue
103	Acacia Clair Acacia Clara Light Acacia	104	Acacia Foncé Acacia Oscura Dark Acacia
209	Chêne Veiné Castaño Claro Oak	235	Chêne Grisé Castaño Oscuro Dark Oak



# CLOISONNETTES FRONTALES | PLAFONES | FRONT SCREENS

1 NIVEAU / 1 NIVEL / 1 LEVEL



2 NIVEAUX / 2 NIVELES / 2 LEVELS

MODÈLE / VARIANTES / VERSIONS	L.	RÉFÉRENCE / REFERENCIA / CODE
		   RAL 9006 RAL 9016 RAL 7022
Indiv. / Individ. / Single		
180 cm		386.008.000 386.108.000 386.208.000
160 cm		386.009.000 386.109.000 386.209.000
140 cm		386.010.000 386.110.000 386.210.000
Vis à vis / Enfrentadas / Face to face		
180 cm		596.110.000 596.210.000 596.310.000
160 cm		596.111.000 596.211.000 596.311.000
140 cm		596.112.000 596.212.000 596.312.000
120°		386.012.000 386.112.000 386.212.000

Tissu  
Tapizado  
Upholstered

FINITIONS  
ACABADOS  
FINISHES

Cf. page 464  
Ver pagina 464  
See page 464

MODÈLE / VARIANTES / VERSIONS	L.	RÉFÉRENCE / REFERENCIA / CODE
		   RAL 9006 RAL 9016 RAL 7022
Indiv. / Individ. / Single		
180 cm		386.021.000 386.121.000 386.221.000
160 cm		386.022.000 386.122.000 386.222.000
140 cm		386.023.000 386.123.000 386.223.000
Vis à vis / Enfrentadas / Face to face		
180 cm		596.120.000 596.220.000 596.320.000
160 cm		596.121.000 596.221.000 596.321.000
140 cm		596.122.000 596.222.000 596.322.000
120°		386.025.000 386.125.000 386.225.000

Tissu  
Tapizado  
Upholstered

FINITIONS  
ACABADOS  
FINISHES

Cf. page 464  
Ver pagina 464  
See page 464

MODÈLE / VARIANTES / VERSIONS	L.	RÉFÉRENCE / REFERENCIA / CODE
Indiv. / Individ. / Single		
180 cm		386.008.--- 386.108.--- 386.208.---
160 cm		386.009.--- 386.109.--- 386.209.---
140 cm		386.010.--- 386.110.--- 386.210.---
Vis à vis / Enfrentadas / Face to face		
180 cm		596.110.--- 596.210.--- 596.310.---
160 cm		596.111.--- 596.211.--- 596.311.---
140 cm		596.112.--- 596.212.--- 596.312.---
120°		386.012.--- 386.112.--- 386.212.---

Méthacrylate  
Metacrilato  
Methacrylate

FINITIONS  
ACABADOS  
FINISHES

411 Transparent  
Transparente  
Clear

412 Blanc opaque  
Translúcido  
Translucent

MODÈLE / VARIANTES / VERSIONS	L.	RÉFÉRENCE / REFERENCIA / CODE
Indiv. / Individ. / Single		
180 cm		386.021.--- 386.121.--- 386.221.---
160 cm		386.022.--- 386.122.--- 386.222.---
140 cm		386.023.--- 386.123.--- 386.223.---
Vis à vis / Enfrentadas / Face to face		
180 cm		596.120.--- 596.220.--- 596.320.---
160 cm		596.121.--- 596.221.--- 596.321.---
140 cm		596.122.--- 596.222.--- 596.322.---
120°		386.025.--- 386.125.--- 386.225.---

Avec méthacrylate et tissu  
Con metacrilato y tapizado  
With methacrylate and  
upholstered

FINITIONS  
ACABADOS  
FINISHES

406 Transparent  
Transparente  
Clear

427 Blanc opaque  
Translúcido  
Translucent

Cf. page 464  
Ver pagina 464  
See page 464

MODÈLE / VARIANTES / VERSIONS	L.	RÉFÉRENCE / REFERENCIA / CODE
Indiv. / Individ. / Single		
180 cm		596.113.838 596.213.838 596.313.838
160 cm		596.114.838 596.214.838 596.314.838
140 cm		596.115.838 596.215.838 596.315.838
Vis à vis / Enfrentadas / Face to face		
180 cm		596.116.838 596.216.838 596.316.838
160 cm		596.117.838 596.217.838 596.317.838
140 cm		596.118.838 596.218.838 596.318.838
120°		596.119.838 596.219.838 596.319.838

Acoustique  
Acústico  
Acoustic

FINITIONS  
ACABADOS  
FINISHES

Cf. page 464  
Ver pagina 464  
See page 464

# TRAM

Bureau réglable en hauteur qui permet de travailler en position assise ou debout selon les besoins de chaque tâche, favorisant le bien-être des personnes. Un bureau capable de satisfaire à la fois le travail concentré et le travail collaboratif.

Mesa regulable en altura que permite trabajar en una postura sentada o de pie según las necesidades de cada tarea fomentando el bienestar de las personas. Un escritorio capaz de satisfacer tanto el trabajo de concentración como el de colaboración.

Height-adjustable table that allows you to work in a sitting or standing posture according to the needs of each task and thereby avoiding a sedentary lifestyle. The perfect workstation for every kind of desk-job.

## PLATEAU / SOBRE / DESK TOP

Mélamine / Melamina / Melamine: 25 mm  
Chant en ABS / Canto ABS / ABS edges

## STRUCTURE / ESTRUCTURA / FRAME - BASIC

Acier: 70 x 70 x 2 mm  
Acero: 70 x 70 x 2 mm  
Steel: 70 x 70 x 2 mm

## STRUCTURE / ESTRUCTURA / FRAME - PLUS

Acier: 75 x 75 x 2 mm  
Acero: 75 x 75 x 2 mm  
Steel: 75 x 75 x 2 mm

## FINITION STRUCTURE / ACABADO ESTRUCTURA / FRAME FINISH

Peinture époxy  
Pintura epoxi  
Epoxy paint

## HAUTEUR / ALTURA / HEIGHT - BASIC

71,5 cm < 117,5 cm

## HAUTEUR / ALTURA / HEIGHT - PLUS

60 cm < 130 cm

## OPTION / OPCIÓN / OPTION

Goulotte / Bandeja electrificación / Cable tray  
Support écran / Soporte pantalla / Monitor holder  
Cloisonnettes / Plafones / Screens

BUREAU TRAM  
PLUS - AVEC RETOUR  
SÉCRETAIRE

MESA TRAM  
PLUS CON ALA

TRAM PLUS  
DESK WITH  
RETURN

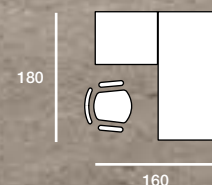



BUREAU TRAM  
PLUS - AVEC  
BOÎTIER MÉMOIRES

MESA  
TRAM PLUS  
PROGRAMABLE

TRAM PLUS DESK WITH  
4 MEMOIRES DIGITAL  
DISPLAY

Boîtier 4 mémoires.  
Controlador PROGRAMABLE de cuatro memorias.  
4-MEMORIES display.

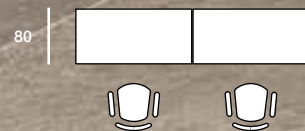

BUREAUX TRAM PLUS  
- EN VIS À VIS AVEC  
CLOISONNETTES  
FRONTALES

MESAS  
TRAM PLUS  
ENFRENTADAS  
CON PLAFÓN

2 FACE TO FACE  
TRAM PLUS DESKS  
WITH FRONT  
SCREENS

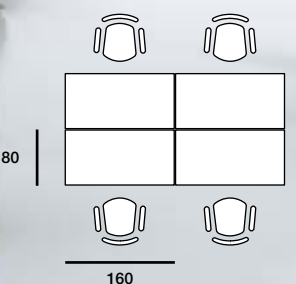



Boîtier UP/DOWN.  
Controlador UP/DOWN.  
UP & DOWN display.



| BUREAU TRAM BASIC  
| AVEC BOÎTIER UP&DOWN

| MESA TRAM BASIC CON  
| MECANISMO UP&DOWN

| TRAM BASIC DESK WITH  
| UP&DOWN DISPLAY

## MODÈLES | VARIANTES | VERSIONS

### TRAM BASIC - BOÎTIER UP & DOWN / MECANISMO UP & DOWN / UP & DOWN DISPLAY

MODÈLE / VARIANTES / VERSIONS	DIMENSIONS / MEDIDAS / MEASUREMENTS	RÉFÉRENCE / REFERENCIA / CODE	
	180 x 80 cm 160 x 80 cm 140 x 80 cm 120 x 80 cm	841.102.-- 841.103.-- 841.104.-- 841.105.--	841.202.-- 841.203.-- 841.204.-- 841.205.--

Bureaux individuel  
Mesa individual  
Individual desk

### TRAM PLUS - BOÎTIER 4 MÉMOIRES / CONTROLADOR PROGRAMABLE / 4-MEMORIES DISPLAY

MODÈLE / VARIANTES / VERSIONS	DIMENSIONS / MEDIDAS / MEASUREMENTS	RÉFÉRENCE / REFERENCIA / CODE	
	180 x 80 cm 160 x 80 cm 140 x 80 cm 120 x 80 cm	841.112.-- 841.113.-- 841.114.-- 841.115.--	841.212.-- 841.213.-- 841.214.-- 841.215.--

Bureaux individuel  
Mesa individual  
Individual desk

	180 x 160 cm 160 x 160 cm 140 x 160 cm 120 x 160 cm	841.122.-- 841.123.-- 841.124.-- 841.125.--	841.222.-- 841.223.-- 841.224.-- 841.225.--
---	--	--	--













Bureaux avec retour secrétaire  
Mesa con ala  
Desk with return

	180 x 160 cm 160 x 160 cm 140 x 160 cm 120 x 160 cm	841.142.-- 841.143.-- 841.144.-- 841.145.--	841.242.-- 841.243.-- 841.244.-- 841.245.--
---	--	--	--

Ensemble de 2 bureaux en vis à vis  
Conjunto de 2 mesas enfrentadas  
Composition of 2 Face to face desks

## FINITIONS | ACABADOS | FINISHES

### STRUCTURE / ESTRUCTURA / FRAME | PLATEAU / SOBRE / DESKTOP

 Argent Plata Silver RAL 9006	 Blanc Blanco White	 Gris Gris Grey	 Hêtre Haya Beech	 Chêne Moyen Roble Maple
 Blanc Blanco White RAL 9016	 Poirier Peral Pear	 Wengué Wengue Wengue	 Acacia Clair Acacia Clara Light Acacia	 Acacia Foncé Acacia Oscura Dark Acacia
 Graphite Grafito Graphite	 Chêne Veiné Castaño Claro Oak	 Chêne Grisé Castaño Oscuro Dark Oak		

## COMPLÉMENTS | COMPLEMENTOS | COMPLEMENTS

MODÈLE / VARIANTES / VERSIONS	DIMENSIONS / MEDIDAS / MEASUREMENTS	RÉFÉRENCE / REFERENCIA / CODE	
	80 x 9,8 x 11,4 cm	1.846.002.111	1.846.002.108

Goulotte individuelle  
Bandeja electrificación individual  
Cable tray

	Individuel / Individual / Single	846.693.111	846.693.108
	Double / Doble / Double	846.694.111	846.694.108

Support écran  
Soporte pantalla  
Monitor holder

## FINITIONS | ACABADOS | FINISHES



### STRUCTURE / ESTRUCTURA / FRAME

 Argent Plata Silver RAL 9006	 Blanc Blanco White RAL 9016
---	--

# CLOISONNETTES FRONTALES | PLAFONES | FRONT SCREENS

1 NIVEAU / 1 NIVEL / 1 LEVEL

2 NIVEAUX / 2 NIVELES / 2 LEVELS

MODÈLE / VARIANTES / VERSIONS	L.	RÉFÉRENCE / REFERENCIA / CODE	MODÈLE / VARIANTES / VERSIONS	L.	RÉFÉRENCE / REFERENCIA / CODE
	Indiv. / Indiv. / Single	RAL 9006 RAL 9016 386.008... 386.108... 386.009... 386.109... 386.010... 386.110... 386.011... 386.111...		Indiv. / Indiv. / Single	RAL 9006 RAL 9016 386.021... 386.121... 386.022... 386.122... 386.023... 386.123... 386.024... 386.124...
<b>FINITIONS ACABADOS FINISHES</b>			<b>FINITIONS ACABADOS FINISHES</b>		
053 Blanc Blanco White	054 Gris Gris Grey	051 Argent Plata Silver	204 Graphite Grafito Graphite	088 Argent Plata Silver	
061 Chêne Moyen Roble Maple	062 Poirier Peral Pear	116 Wengué Wengue Wengue	081 Blanc Blanco White	197 Gris Gris Grey	
103 Acacia Clair Acacia Clara Light Acacia	104 Acacia Foncé Acacia Oscura Dark Acacia	272 Chêne Veiné Castaño Claro Oak	199 Chêne Moyen Roble Maple	200 Poirier Peral Pear	
273 Chêne Gris Castaño Oscuro Dark Oak			103 Acacia Clair Acacia Clara Light Acacia	104 Acacia Foncé Acacia Oscura Dark Acacia	
			235 Chêne Gris Castaño Oscuro Dark Oak		

MODÈLE / VARIANTES / VERSIONS	L.	RÉFÉRENCE / REFERENCIA / CODE
	Vis à vis / Enfrentadas / Face to face	180 cm 846.112... 846.212... 160 cm 846.114... 846.214... 140 cm 846.116... 846.216... 120 cm 846.118... 846.218...

Mélamine Melamina Melamine

MODÈLE / VARIANTES / VERSIONS	L.	RÉFÉRENCE / REFERENCIA / CODE
<b>FINITIONS ACABADOS FINISHES</b>		
053 Blanc Blanco White	054 Gris Gris Grey	051 Argent Plata Silver
061 Chêne Moyen Roble Maple	062 Poirier Peral Pear	116 Wengué Wengue Wengue
103 Acacia Clair Acacia Clara Light Acacia	104 Acacia Foncé Acacia Oscura Dark Acacia	272 Chêne Veiné Castaño Claro Oak
273 Chêne Gris Castaño Oscuro Dark Oak		

MODÈLE / VARIANTES / VERSIONS	L.	RÉFÉRENCE / REFERENCIA / CODE
	Vis à vis / Enfrentadas / Face to face	180 cm 846.122... 846.222... 160 cm 846.124... 846.224... 140 cm 846.126... 846.226... 120 cm 846.128... 846.228...

Cloisonnette en méthacrylate et en mélamine - sans profilé en aluminium  
Metacrilato y melamina sin perfil de aluminio  
Methacrylate and melamine screen - without aluminium profile

MODÈLE / VARIANTES / VERSIONS	L.	RÉFÉRENCE / REFERENCIA / CODE
<b>FINITIONS ACABADOS FINISHES</b>		
413 Blanc Blanco White	414 Gris Gris Grey	408 Graphite Grafito Graphite
416 Chêne Moyen Roble Maple	417 Poirier Peral Pear	409 Argent Plata Silver
626 Acacia Clair Acacia Clara Light Acacia	627 Acacia Foncé Acacia Oscura Dark Acacia	415 Hêtre Haya Beech
893 Chêne Gris Castaño Oscuro Dark Oak		418 Wengué Wengue Wengue

# CLOISONNETTES FRONTALES | PLAFONES | FRONT SCREENS

1 NIVEAU / 1 NIVEL / 1 LEVEL

2 NIVEAUX / 2 NIVELES / 2 LEVELS

MODÈLE / VARIANTES / VERSIONS	L.	RÉFÉRENCE / REFERENCIA / CODE	MODÈLE / VARIANTES / VERSIONS	L.	RÉFÉRENCE / REFERENCIA / CODE
	Indiv. / Indiv. / Single	RAL 9006 RAL 9016 386.008.000 386.108.000 386.009.000 386.109.000 386.010.000 386.110.000 386.011.000 386.111.000		Indiv. / Indiv. / Single	RAL 9006 RAL 9016 386.021.000 386.121.000 386.022.000 386.122.000 386.023.000 386.123.000 386.024.000 386.124.000
<b>FINITIONS ACABADOS FINISHES</b>			<b>FINITIONS ACABADOS FINISHES</b>		
053 Blanc Blanco White	054 Gris Gris Grey	051 Argent Plata Silver	204 Graphite Grafito Graphite	088 Argent Plata Silver	
061 Chêne Moyen Roble Maple	062 Poirier Peral Pear	116 Wengué Wengue Wengue	081 Blanc Blanco White	197 Gris Gris Grey	
103 Acacia Clair Acacia Clara Light Acacia	104 Acacia Foncé Acacia Oscura Dark Acacia	272 Chêne Veiné Castaño Claro Oak	199 Chêne Moyen Roble Maple	200 Poirier Peral Pear	
273 Chêne Gris Castaño Oscuro Dark Oak			103 Acacia Clair Acacia Clara Light Acacia	104 Acacia Foncé Acacia Oscura Dark Acacia	
			235 Chêne Gris Castaño Oscuro Dark Oak		

MODÈLE / VARIANTES / VERSIONS	L.	RÉFÉRENCE / REFERENCIA / CODE
	Vis à vis / Enfrentadas / Face to face	180 cm 846.112.000 846.212.000 160 cm 846.114.000 846.214.000 140 cm 846.116.000 846.216.000 120 cm 846.118.000 846.218.000

Cloisonnette tissu - sans profilé en aluminium.  
Tapizado sin perfil de aluminio.  
Upholstered screen - without aluminium profile.

Acoustique Acústico Acoustic

MODÈLE / VARIANTES / VERSIONS	L.	RÉFÉRENCE / REFERENCIA / CODE
	Indiv. / Indiv. / Single	180 cm 386.008... 386.108... 160 cm 386.009... 386.109... 140 cm 386.010... 386.110... 120 cm 386.011... 386.111...

Méthacrylate Metacrilato Methacrylate

MODÈLE / VARIANTES / VERSIONS	L.	RÉFÉRENCE / REFERENCIA / CODE
<b>FINITIONS ACABADOS FINISHES</b>		
411 Transparente Clear	412 Blanc opaque Translúcido Translucent	

MODÈLE / VARIANTES / VERSIONS	L.	RÉFÉRENCE / REFERENCIA / CODE
	Indiv. / Indiv. / Single	180 cm 846.122.406 846.222.406 160 cm 846.124.406 846.224.406 140 cm 846.126.406 846.226.406 120 cm 846.128.406 846.228.406

Cloisonnette en méthacrylate et en tissu - sans profilé en aluminium  
Metacrilato y tapizado sin perfil de aluminio  
Methacrylate and upholstered screen - without aluminium profile

Avec méthacrylate et tissu  
Con metacrilato y tapizado  
With methacrylate and upholstered

MODÈLE / VARIANTES / VERSIONS	L.	RÉFÉRENCE / REFERENCIA / CODE
	Indiv. / Indiv. / Single	180 cm 386.008... 386.108... 160 cm 386.009... 386.109... 140 cm 386.010... 386.110... 120 cm 386.011... 386.111...

Méthacrylate Metacrilato Methacrylate

MODÈLE / VARIANTES / VERSIONS	L.	RÉFÉRENCE / REFERENCIA / CODE
<b>FINITIONS ACABADOS FINISHES</b>		
406 Transparente Clear	427 Blanc opaque Translúcido Translucent	

MOBILIER MODULAIRE  
INSTALACIONES  
DESK SYSTEMS



044 | STAR



056 | STAR RANGE



074 | BORN



086 | TEMPO



096 | ECO

# star

La gamme STAR est le fruit de l'évolution de nos recherches et système de développement.

STAR es, sin duda, una apuesta de futuro en el desarrollo y evolución del mobiliario de oficina. Fruto de la evolución del sistema de desarrollo y estudio, nace este programa.

STAR is the future in office furniture. It was born as a result of ongoing research and development systems.

## PLATEAU / SOBRE / DESK TOP

Mélamine / Melamina / Melamine: 25 mm  
Stratifié / Estratificado / Stratified: 13 mm  
Phénolique / Fenólico / Phenolic: 13 mm  
Verre / Vidrio / Glass: 10 mm

Chant en ABS / Canto ABS / ABS edges

## STRUCTURE / ESTRUCTURA / FRAME

Acier: 50 x 50 x 1,8 mm  
Acero: 60 x 60 x 1,5 mm  
Steel: 60 x 60 x 1,5 mm



prof./depth 80/60 prof./depth 100/120

## FINITION STRUCTURE / ACABADO ESTRUCTURA / FRAME FINISH

Peinture époxy  
Pintura epoxi  
Epoxy paint

## HAUTEUR / ALTURA / HEIGHT

73 cm

## OPTION / OPCIÓN / OPTION

Voile de fond / Faldón / Modesty panel  
Goulotte / Bandeja electrificación / Cable tray  
Support écran / Soporte pantalla / Monitor holder  
Cloisonnettes / Plafones / Screens



BUREAUX EN  
VIS À VIS AVEC  
PIÉTEMENT FERMÉ

MESAS  
ENFRENTADAS CON  
LATERAL CERRADO

FACE TO FACE  
DESKS WITH  
LOOP LEG



BUREAU  
INDIVIDUEL AVEC  
PIÉTEMENT OUVERT

MESA  
CON LATERAL  
ABIERTO

U-SHAPE  
FRAME  
TABLE



BUREAU  
INDIVIDUEL  
AVEC RETOUR

MESA  
CON ALA

DESK WITH  
RETURN

Combinable avec caissons et crédences.  
Combinable con cajoneras y credencias.  
Combine with pedestals and credenzas.

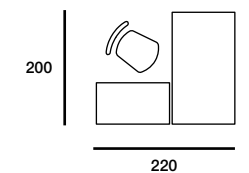
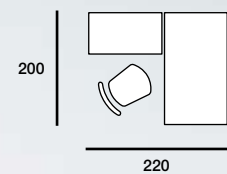





Plateau coulissant sur 14 cm.  
El sobre puede deslizarse 14 cm.  
Sliding top 14 cm.

BUREAUX  
EN VIS À VIS  
AVEC CRÉDENCE

MESAS  
ENFRENTADAS  
CON CREDENCIA

FACE TO FACE  
DESKS WITH  
SIDE CREDENZA

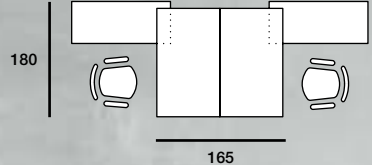



# MODÈLES | VARIANTES | VERSIONS

## PIÉTEMENT OUVERT / PATA ABIERTA / U-SHAPE LEG

MODÈLE / VARIANTES / VERSIONS	TYPE / TIPO / TYPE	DIMENSIONS / MEDIDAS / MEASUREMENTS	RÉFÉRENCE / REFERENCIA / CODE			
 <p><b>Bureau individuel</b> Mesa individual Individual desks</p>		220 x 100 cm 200 x 100 cm	351.100.- 351.101.-	351.200.- 351.201.-	351.300.- 351.301.-	
		180 x 80 cm 160 x 80 cm 140 x 80 cm 120 x 80 cm 100 x 80 cm 80 x 80 cm	351.102.- 351.103.- 351.104.- 351.105.- 351.106.- 351.107.-	351.202.- 351.203.- 351.204.- 351.205.- 351.206.- 351.207.-	351.302.- 351.303.- 351.304.- 351.305.- 351.306.- 351.307.-	
	À Droite / Derecha / Right	160 x 160 cm	351.132.-	351.232.-	351.332.-	
		200 x 100 cm	351.134.-	351.234.-	351.334.-	
		180 x 80 cm 160 x 80 cm	351.136.- 351.138.-	351.236.- 351.238.-	351.336.- 351.338.-	
	À Gauche / Izquierda / Left	160 x 160 cm	351.133.-	351.233.-	351.333.-	
		200 x 100 cm	351.135.-	351.235.-	351.335.-	
180 x 80 cm 160 x 80 cm		351.137.- 351.139.-	351.237.- 351.239.-	351.337.- 351.339.-		
 <p><b>Bureaux alignés</b> Mesas lineales Side by side desks</p>		360 x 80 cm 320 x 80 cm 280 x 80 cm 240 x 80 cm 200 x 80 cm 160 x 80 cm	351.108.- 351.109.- 351.110.- 351.111.- 351.112.- 351.113.-	351.208.- 351.209.- 351.210.- 351.211.- 351.212.- 351.213.-	351.308.- 351.309.- 351.310.- 351.311.- 351.312.- 351.313.-	
	4 bureaux / mesas / desktops	Type "A" / Tipo "A" / Type "A"	360 x 165 cm 320 x 165 cm 280 x 165 cm 200 x 165 cm	351.120.- 351.121.- 351.122.- 351.123.-	351.220.- 351.221.- 351.222.- 351.223.-	351.320.- 351.321.- 351.322.- 351.323.-
		Type "B" / Tipo "B" / Type "B"	360 x 161 cm 320 x 161 cm 280 x 161 cm 200 x 161 cm	358.120.- 358.121.- 358.122.- 358.123.-	358.220.- 358.221.- 358.222.- 358.223.-	358.320.- 358.321.- 358.322.- 358.323.-
		Type "A" / Tipo "A" / Type "A"	180 x 165 cm 160 x 165 cm 140 x 165 cm 100 x 165 cm	351.128.- 351.129.- 351.130.- 351.131.-	351.228.- 351.229.- 351.230.- 351.231.-	351.328.- 351.329.- 351.330.- 351.331.-
		Type "B" / Tipo "B" / Type "B"	180 x 161 cm 160 x 161 cm 140 x 161 cm 100 x 161 cm	358.128.- 358.129.- 358.130.- 358.131.-	358.228.- 358.229.- 358.230.- 358.231.-	358.328.- 358.329.- 358.330.- 358.331.-
	2 bureaux / mesas / desktops	Type "A" / Tipo "A" / Type "A"	180 x 165 cm 160 x 165 cm 140 x 165 cm 100 x 165 cm	351.140.- 351.141.- 351.142.-	351.240.- 351.241.- 351.242.-	351.340.- 351.341.- 351.342.-
Type "B" / Tipo "B" / Type "B"		180 x 161 cm 160 x 161 cm 140 x 161 cm 100 x 161 cm	358.140.- 358.141.- 358.142.-	358.240.- 358.241.- 358.242.-	358.340.- 358.341.- 358.342.-	
Type "A" / Tipo "A" / Type "A"		180 x 165 cm 160 x 165 cm 140 x 165 cm	351.143.- 351.144.- 351.145.-	351.243.- 351.244.- 351.245.-	351.343.- 351.344.- 351.345.-	
Type "B" / Tipo "B" / Type "B"		180 x 161 cm 160 x 161 cm 140 x 161 cm	358.143.- 358.144.- 358.145.-	358.243.- 358.244.- 358.245.-	358.343.- 358.344.- 358.345.-	

## PIÉTEMENT FERMÉ / PATA CERRADA / LOOP LEGS

MODÈLE / VARIANTES / VERSIONS	TYPE / TIPO / TYPE	DIMENSIONS / MEDIDAS / MEASUREMENTS	RÉFÉRENCE / REFERENCIA / CODE			
 <p><b>Bureau individuel</b> Mesa individual Individual desks</p>		220 x 100 cm 200 x 100 cm	357.100.- 357.101.-	357.200.- 357.201.-	357.300.- 357.301.-	
		180 x 80 cm 160 x 80 cm 140 x 80 cm	357.102.- 357.103.- 357.104.-	357.202.- 357.203.- 357.204.-	357.302.- 357.303.- 357.304.-	
 <p><b>Bureaux en vis à vis</b> Mesas enfrentadas Face to face desks</p>	4 bureaux / mesas / desktops	Type "A" / Tipo "A" / Type "A"	360 x 165 cm 320 x 165 cm 280 x 165 cm 200 x 165 cm	357.107.- 357.108.- 357.109.- 357.110.-	357.207.- 357.208.- 357.209.- 357.210.-	357.307.- 357.308.- 357.309.- 357.310.-
		Type "B" / Tipo "B" / Type "B"	360 x 161 cm 320 x 161 cm 280 x 161 cm 200 x 161 cm	359.107.- 359.108.- 359.109.- 359.110.-	359.207.- 359.208.- 359.209.- 359.210.-	359.307.- 359.308.- 359.309.- 359.310.-
		Type "A" / Tipo "A" / Type "A"	180 x 165 cm 160 x 165 cm 140 x 165 cm 100 x 165 cm	357.115.- 357.116.- 357.117.- 357.118.-	357.215.- 357.216.- 357.217.- 357.218.-	357.315.- 357.316.- 357.317.- 357.318.-
		Type "B" / Tipo "B" / Type "B"	180 x 161 cm 160 x 161 cm 140 x 161 cm 100 x 161 cm	359.115.- 359.116.- 359.117.- 359.118.-	359.215.- 359.216.- 359.217.- 359.218.-	359.315.- 359.316.- 359.317.- 359.318.-
	2 bureaux / mesas / desktops	Type "A" / Tipo "A" / Type "A"	180 x 165 cm 160 x 165 cm 140 x 165 cm	357.119.- 357.120.- 357.121.-	357.219.- 357.220.- 357.221.-	357.319.- 357.320.- 357.321.-
		Type "B" / Tipo "B" / Type "B"	180 x 161 cm 160 x 161 cm 140 x 161 cm	359.119.- 359.120.- 359.121.-	359.219.- 359.220.- 359.221.-	359.319.- 359.320.- 359.321.-

## FINITIONS | ACABADOS | FINISHES

### STRUCTURE / ESTRUCTURA / FRAME | PLATEAU / SOBRE / DESKTOP

### TYPE / TIPO / TYPE A

Structure pour cloisonnettes / Apta para plafones / Screens available

### TYPE / TIPO / TYPE B

Structure sans cloisonnettes / No apta para plafones / Screens no available

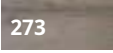
 Argent Plata Silver	 Blanc Blanco White	 Gris Gris Grey	 Hêtre Haya Beech	 Chêne Moyen Roble Maple
 Blanc Blanco White	 Poirier Peral Pear	 Wengué Wengue Wengue	 Acacia Clair Acacia Clara Light Acacia	 Acacia Foncé Acacia Oscura Dark Acacia
 Graphite Grafito Graphite	 Graphite Grafito Graphite	 Chêne Veiné Castaño Claro Oak	 Chêne Grisé Castaño Oscuro Dark Oak	

# COMPLÉMENTS | COMPLEMENTOS | COMPLEMENTS

MODÈLE / VARIANTES / VERSIONS	DIMENSIONS / MEDIDAS / MEASUREMENTS	RÉFÉRENCE / REFERENCIA / CODE		
	120 x 60 cm 80 x 60 cm	351.191... 351.190...	351.291... 351.290...	351.391... 351.390...
	158 x 118 cm	351.196...	351.296...	351.396...
	80 x 40 cm	351.197...	351.297...	351.397...
	165 x 70 cm	351.198...	351.298...	351.398...
	165 x 40 cm	351.199...	351.299...	351.399...

# FINITIONS | ACABADOS | FINISHES

STRUCTURE / ESTRUCTURA / FRAME | PLATEAU / SOBRE / DESKTOP

# COMPLÉMENTS | COMPLEMENTOS | COMPLEMENTS

MODÈLE / VARIANTES / VERSIONS	DIMENSIONS / MEDIDAS / MEASUREMENTS	RÉFÉRENCE / REFERENCIA / CODE		
	Mélamine / Melamina / Melamine 220 cm 200 cm 180 cm 160 cm 140 cm 120 cm 100 cm 80 cm	1.351.702.051 1.351.704.051 1.351.706.051 1.351.708.051 1.351.710.051 1.351.712.051 1.351.714.051 1.351.716.051	1.351.702.053 1.351.704.053 1.351.706.053 1.351.708.053 1.351.710.053 1.351.712.053 1.351.714.053 1.351.716.053	1.351.702.007 1.351.704.007 1.351.706.007 1.351.708.007 1.351.710.007 1.351.712.007 1.351.714.007 1.351.716.007
	Métal / Metal / Metal 220 cm 200 cm 180 cm 160 cm 140 cm 120 cm 100 cm 80 cm	1.351.720.111 1.351.721.111 1.351.722.111 1.351.723.111 1.351.724.111 1.351.725.111 1.351.726.111 1.351.727.111	1.351.720.108 1.351.721.108 1.351.722.108 1.351.723.108 1.351.724.108 1.351.725.108 1.351.726.108 1.351.727.108	1.351.720.107 1.351.721.107 1.351.722.107 1.351.723.107 1.351.724.107 1.351.725.107 1.351.726.107 1.351.727.107
	Indiv. / Individ. / Single 220 cm 200 cm 180 cm 160 cm 140 cm 120 cm 100 cm 80 cm	1.356.300.111 1.356.301.111 1.356.302.111 1.356.303.111 1.356.304.111 1.356.305.111 1.356.306.111 1.356.307.111	1.356.300.108 1.356.301.108 1.356.302.108 1.356.303.108 1.356.304.108 1.356.305.108 1.356.306.108 1.356.307.108	1.356.300.107 1.356.301.107 1.356.302.107 1.356.303.107 1.356.304.107 1.356.305.107 1.356.306.107 1.356.307.107
	Pour bureaux / para mesas / for desks: 220 cm 200 cm 180 cm 160 cm 140 cm 120 cm 100 cm 80 cm	1.356.310.111 1.356.311.111 1.356.312.111 1.356.313.111 1.356.314.111	1.356.310.108 1.356.311.108 1.356.312.108 1.356.313.108 1.356.314.108	1.356.310.107 1.356.311.107 1.356.312.107 1.356.313.107 1.356.314.107
	Pour tables de réunion et bureaux en vis à vis / Para mesas de reunión y enfrentadas / For meeting tables and face to face desks 250 cm 200 cm 180 cm 160 cm 140 / 150 cm 120 100 80	1.356.310.111 1.356.311.111 1.356.312.111 1.356.313.111 1.356.314.111 1.356.315.111 1.356.316.111 1.356.317.111	1.356.310.108 1.356.311.108 1.356.312.108 1.356.313.108 1.356.314.108 1.356.315.108 1.356.316.108 1.356.317.108	1.356.310.107 1.356.311.107 1.356.312.107 1.356.313.107 1.356.314.107 1.356.315.107 1.356.316.107 1.356.317.107
	Individuel / Individual / Single	846.693.111	846.693.108	
	Double / Doble / Double	846.694.111	846.694.108	

# FINITIONS | ACABADOS | FINISHES

STRUCTURE / ESTRUCTURA / FRAME

--	--	--

# CLOISONNETTES FRONTALES | PLAFONES | FRONT SCREENS

1 NIVEAU / 1 NIVEL / 1 LEVEL

2 NIVEAUX / 2 NIVELES / 2 LEVELS

MODÈLE / VARIANTES / VERSIONS	L.	RÉFÉRENCE / REFERENCIA / CODE		
	Indiv. / Indiv. / Single	RAL 9006	RAL 9016	RAL 7022
	180 cm	356.001.-..	356.101.-..	356.201.-..
	160 cm	356.002.-..	356.102.-..	356.202.-..
	140 cm	356.003.-..	356.103.-..	356.203.-..
	120 cm	356.004.-..	356.104.-..	356.204.-..
	100 cm	356.005.-..	356.105.-..	356.205.-..
Vis à vis / Enfrentadas / Face to face	180 cm	356.007.-..	356.107.-..	356.207.-..
	160 cm	356.008.-..	356.108.-..	356.208.-..
	140 cm	356.009.-..	356.109.-..	356.209.-..
	120 cm	356.010.-..	356.110.-..	356.210.-..
	100 cm	356.011.-..	356.111.-..	356.211.-..
	80 cm	356.012.-..	356.112.-..	356.212.-..

FINITIONS ACABADOS FINISHES		007		051	
053	Blanc Blanco White	054	Gris Gris Grey	055	Hêtre Haya Beech
061	Chêne Moyen Roble Maple	062	Poirier Peral Pear	116	Wengué Wengue Wengue
103	Acacia Clair Acacia Clara Light Acacia	104	Acacia Foncé Acacia Oscura Dark Acacia	272	Chêne Veiné Castaño Claro Oak
273	Chêne Grisé Castaño Oscuro Dark Oak				

FINITIONS ACABADOS FINISHES		204		088	
081	Blanc Blanco White	197	Gris Gris Grey	198	Hêtre Haya Beech
199	Chêne Moyen Roble Maple	200	Poirier Peral Pear	202	Wengué Wengue Wengue
103	Acacia Clair Acacia Clara Light Acacia	104	Acacia Foncé Acacia Oscura Dark Acacia	209	Chêne Veiné Castaño Claro Oak
235	Chêne Grisé Castaño Oscuro Dark Oak				



# CLOISONNETTES FRONTALES | PLAFONES | FRONT SCREENS

1 NIVEAU / 1 NIVEL / 1 LEVEL

2 NIVEAUX / 2 NIVELES / 2 LEVELS

MODÈLE / VARIANTES / VERSIONS	L.	RÉFÉRENCE / REFERENCIA / CODE		
	Indiv. / Indiv. / Single	RAL 9006	RAL 9016	RAL 7022
	180 cm	356.001.000	356.101.000	356.201.000
	160 cm	356.002.000	356.102.000	356.202.000
	140 cm	356.003.000	356.103.000	356.203.000
	120 cm	356.004.000	356.104.000	356.204.000
	100 cm	356.005.000	356.105.000	356.205.000
Vis à vis / Enfrentadas / Face to face	180 cm	356.007.000	356.107.000	356.207.000
	160 cm	356.008.000	356.108.000	356.208.000
	140 cm	356.009.000	356.109.000	356.209.000
	120 cm	356.010.000	356.110.000	356.210.000
	100 cm	356.011.000	356.111.000	356.211.000
	80 cm	356.012.000	356.112.000	356.212.000

FINITIONS ACABADOS FINISHES		Cf. page 464 Ver página 464 See page 464	

FINITIONS ACABADOS FINISHES		Cf. page 464 Ver página 464 See page 464	

MODÈLE / VARIANTES / VERSIONS	L.	RÉFÉRENCE / REFERENCIA / CODE		
	Indiv. / Indiv. / Single			
	180 cm	356.001.-..	356.101.-..	356.201.-..
	160 cm	356.002.-..	356.102.-..	356.202.-..
	140 cm	356.003.-..	356.103.-..	356.203.-..
	120 cm	356.004.-..	356.104.-..	356.204.-..
	100 cm	356.005.-..	356.105.-..	356.205.-..
Vis à vis / Enfrentadas / Face to face	180 cm	356.007.-..	356.107.-..	356.207.-..
	160 cm	356.008.-..	356.108.-..	356.208.-..
	140 cm	356.009.-..	356.109.-..	356.209.-..
	120 cm	356.010.-..	356.110.-..	356.210.-..
	100 cm	356.011.-..	356.111.-..	356.211.-..
	80 cm	356.012.-..	356.112.-..	356.212.-..

FINITIONS ACABADOS FINISHES		Cf. page 464 Ver página 464 See page 464	
411	Transparent Transparente Clear	412	Blanc opaque Translucido Translucent

MODÈLE / VARIANTES / VERSIONS	L.	RÉFÉRENCE / REFERENCIA / CODE		
	Indiv. / Indiv. / Single			
	180 cm	356.013.-..	356.113.-..	356.213.-..
	160 cm	356.014.-..	356.114.-..	356.214.-..
	140 cm	356.015.-..	356.115.-..	356.215.-..
	120 cm	356.016.-..	356.116.-..	356.216.-..
	100 cm	356.017.-..	356.117.-..	356.217.-..
Vis à vis / Enfrentadas / Face to face	180 cm	356.021.-..	356.121.-..	356.221.-..
	160 cm	356.022.-..	356.122.-..	356.222.-..
	140 cm	356.023.-..	356.123.-..	356.223.-..
	120 cm	356.024.-..	356.124.-..	356.224.-..
	100 cm	356.025.-..	356.125.-..	356.225.-..
	80 cm	356.026.-..	356.126.-..	356.226.-..

FINITIONS ACABADOS FINISHES		Cf. page 464 Ver página 464 See page 464	
406	Transparent Transparente Clear	427	Blanc opaque Translucido Translucent

MODÈLE / VARIANTES / VERSIONS	L.	RÉFÉRENCE / REFERENCIA / CODE		
	Indiv. / Indiv. / Single			
	180 cm	356.080.838	356.180.838	356.280.838
	160 cm	356.082.838	356.182.838	356.282.838
	140 cm	356.084.838	356.184.838	356.284.838
	120 cm	356.086.838	356.186.838	356.286.838
	100 cm	356.087.838	356.187.838	356.287.838
Vis à vis / Enfrentadas / Face to face	180 cm	356.090.838	356.190.838	356.290.838
	160 cm	356.092.838	356.192.838	356.292.838
	140 cm	356.094.838	356.194.838	356.294.838
	120 cm	356.096.838	356.196.838	356.296.838
	100 cm	356.097.838	356.197.838	356.297.838
	80 cm	356.098.838	356.198.838	356.298.838

FINITIONS ACABADOS FINISHES		Cf. page 464 Ver página 464 See page 464	

star  
range

Cloisonnettes de 1 et 2 niveaux, acoustiques et avec rails pour y accrocher une grande variété d'accessoires et rendre votre poste de travail plus agréable.

Esta ampliación de la serie STAR facilita el crear un espacio de trabajo más cómodo. Separadores de uno y dos niveles, acústicos y con guías junto a una gran variedad de accesorios para hacer de las oficinas un lugar más agradable.

Best accessories to do more comfortable the workstation: one or two levels front screens (acoustics or with guide), toolbar with complements and a wide range of facilities that will make the workspace a better place.

#### MODULE / MÓDULO / LOW STORAGE

Mélamine / Melamina / Melamine: 25 mm  
Stratifié / Estratificado / Stratified: 25 mm  
Phenolique / Fenólico / Phenolic: 13 mm

Chant en ABS / Canto ABS / ABS edges

#### STRUCTURE / ESTRUCTURA / FRAME

Acier: 50 x 50 x 1,8 mm  
Steel: 50 x 50 x 1,8 mm



#### FINITION STRUCTURE / ACABADO ESTRUCTURA / FRAME FINISH

Peinture époxy  
Pintura epoxi  
Epoxy paint

#### HAUTEUR / ALTURA / HEIGHT

Module simple		Avec rangement supérieur
Módulo	58,1 cm	Con altillo
Low storage		High storage
		139,1 cm

#### OPTION / OPCIÓN / OPTION

Voile de fond / Faldón / Modesty panel  
Goulotte / Bandeja electrificación / Cable tray  
Cloisonnettes / Plafones / Screens



MEUBLE DE  
RANGEMENT DOUBLE

MÓDULO  
DOBLE

TWO FACES  
LOW STORAGE

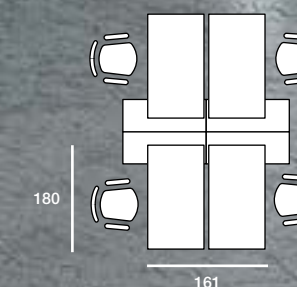



Tiroir DS disponible.  
Cajón archivo disponible.  
File drawer available.



Poignée standard / Tirador estándar / Standard handle

Poignée en option / Tirador opcional / Optional handle

Poignée à choisir.  
Tirador a escoger.  
2 handle types.

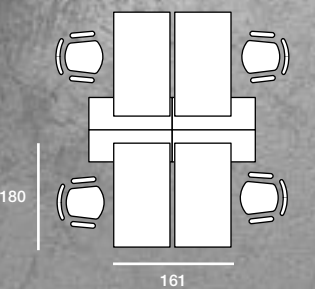

MEUBLE AVEC  
RANGEMENT SUPÉRIEUR

MÓDULO  
CON ALTILLO

LOW AND HIGH  
STORAGE

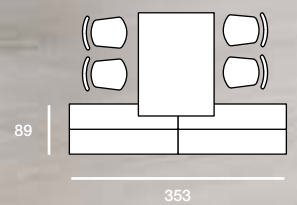

MEUBLE DE  
RANGEMENT INDIVIDUEL

MÓDULO  
INDIVIDUAL

INDIVIDUAL LOW  
STORAGE

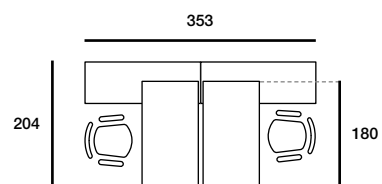





| CLOISONNETTES

| DIVISORIAS

| FRONT SCREENS



# MODÈLES | VARIANTES | VERSIONS

PIÉTEMENT OUVERT / PATA ABIERTA / U-SHAPE LEG

MODÈLE / VARIANTES / VERSIONS	TYPE / TIPO / TYPE	DIMENSIONS / MEDIDAS / MEASUREMENTS	RÉFÉRENCE / REFERENCIA / CODE		
			■	■	■
	À droite / Derecha / Right	180 x 80 cm 160 x 80 cm 140 x 80 cm	353.102... 353.104... 353.106...	353.202... 353.204... 353.206...	353.302... 353.304... 353.306...
	À gauche / Izquierda / Left	180 x 80 cm 160 x 80 cm 140 x 80 cm	353.103... 353.105... 353.107...	353.203... 353.205... 353.207...	353.303... 353.305... 353.307...
	À droite / Derecha / Right	180 x 60 cm 160 x 60 cm 140 x 60 cm	353.112... 353.114... 353.116...	353.212... 353.214... 353.216...	353.312... 353.314... 353.316...
	À gauche / Izquierda / Left	180 x 60 cm 160 x 60 cm 140 x 60 cm	353.113... 353.115... 353.117...	353.213... 353.215... 353.217...	353.313... 353.315... 353.317...

Bureau individuel  
Mesa individual  
Individual desks

	180 x 165 cm 160 x 165 cm 140 x 165 cm	353.120... 353.122... 353.124...	353.220... 353.222... 353.224...	353.320... 353.322... 353.324...
	180 x 125 cm 160 x 125 cm 140 x 125 cm	353.126... 353.128... 353.130...	353.226... 353.228... 353.230...	353.326... 353.328... 353.330...

Bureaux en vis à vis  
Mesas enfrentadas  
Face to face desks

	180 x 160 cm 160 x 160 cm 140 x 160 cm	353.132... 353.134... 353.136...	353.232... 353.234... 353.236...	353.332... 353.334... 353.336...
	180 x 120 cm 160 x 120 cm 140 x 120 cm	353.138... 353.140... 353.142...	353.238... 353.240... 353.242...	353.338... 353.340... 353.342...

Bureaux doubles en 1 seul plateau  
Mesa doble con 1 solo sobre  
Meeting table

# MODÈLES | VARIANTES | VERSIONS

PIÉTEMENT FERMÉ / PATA CERRADA / LOOP LEGS

MODÈLE / VARIANTES / VERSIONS	TYPE / TIPO / TYPE	DIMENSIONS / MEDIDAS / MEASUREMENTS	RÉFÉRENCE / REFERENCIA / CODE		
			■	■	■
	À droite / Derecha / Right	180 x 80 cm 160 x 80 cm 140 x 80 cm	357.132... 357.134... 357.136...	357.232... 357.234... 357.236...	357.332... 357.334... 357.336...
	À gauche / Izquierda / Left	180 x 80 cm 160 x 80 cm 140 x 80 cm	357.133... 357.135... 357.137...	357.233... 357.235... 357.237...	357.333... 357.335... 357.337...
	À droite / Derecha / Right	180 x 60 cm 160 x 60 cm 140 x 60 cm	357.142... 357.144... 357.146...	357.242... 357.244... 357.246...	357.342... 357.344... 357.346...
	À gauche / Izquierda / Left	180 x 60 cm 160 x 60 cm 140 x 60 cm	357.143... 357.145... 357.147...	357.243... 357.245... 357.247...	357.343... 357.345... 357.347...

Bureau individuel  
Mesa individual  
Individual desks

	180 x 165 cm 160 x 165 cm 140 x 165 cm	357.154... 357.155... 357.156...	357.254... 357.255... 357.256...	357.354... 357.355... 357.356...
	180 x 125 cm 160 x 125 cm 140 x 125 cm	357.157... 357.158... 357.159...	357.257... 357.258... 357.259...	357.357... 357.358... 357.359...













Bureaux en vis à vis  
Mesas enfrentadas  
Face to face desks

	180 x 160 cm 160 x 160 cm 140 x 160 cm	357.162... 357.164... 357.166...	357.262... 357.264... 357.266...	357.362... 357.364... 357.366...
	180 x 120 cm 160 x 120 cm 140 x 120 cm	357.168... 357.170... 357.172...	357.268... 357.270... 357.272...	357.368... 357.370... 357.372...

Bureaux doubles en 1 seul plateau  
Mesa doble con 1 solo sobre  
Meeting table















# FINITIONS | ACABADOS | FINISHES

STRUCTURE / ESTRUCTURA / FRAME | PLATEAU / SOBRE / DESKTOP

 Argent Plata Silver RAL 9006	 053 Blanc Blanco White	 054 Gris Gris Grey	 055 Hêtre Haya Beech	 061 Chêne Moyen Roble Maple
 Blanc Blanco White RAL 9016	 062 Poirier Peral Pear	 116 Wengué Wengue Wengue	 103 Acacia Clair Acacia Clara Light Acacia	 104 Acacia Foncé Acacia Oscura Dark Acacia
 Graphite Grafito Graphite RAL 7022	 007 Graphite Grafito Graphite	 272 Chêne Veiné Castaño Claro Oak	 273 Chêne Gris Castaño Oscuro Dark Oak	

# FINITIONS | ACABADOS | FINISHES

STRUCTURE / ESTRUCTURA / FRAME | PLATEAU / SOBRE / DESKTOP

 Argent Plata Silver RAL 9006	 053 Blanc Blanco White	 054 Gris Gris Grey	 055 Hêtre Haya Beech	 061 Chêne Moyen Roble Maple
 Blanc Blanco White RAL 9016	 062 Poirier Peral Pear	 116 Wengué Wengue Wengue	 103 Acacia Clair Acacia Clara Light Acacia	 104 Acacia Foncé Acacia Oscura Dark Acacia
 Graphite Grafito Graphite RAL 7022	 007 Graphite Grafito Graphite	 272 Chêne Veiné Castaño Claro Oak	 273 Chêne Gris Castaño Oscuro Dark Oak	



# MODÈLES | VARIANTES | VERSIONS

## MEUBLE DE RANGEMENT / MÓDULOS / LOW STORAGE

MODÈLE / VARIANTES / VERSIONS	TYPE / TIPO / TYPE	DIMENSIONS / MEDIDAS / MEASUREMENTS	RÉFÉRENCE / REFERENCIA / CODE		
	Individuel / Individual / Single face		2 Tiroirs / Cajones / Drawers + 1 Porte coulissante / Puerta corredera / Sliding door	2 DS / Archivo / File + 1 Porte coulissante / Puerta corredera / Sliding door	2 Portes coulissantes / Puertas correderas / Sliding doors
	À droite / Derecha / Right	176,4 x 44,5 cm	362.001.-.-	362.003.-.-	362.005.-.-
	À gauche / Izquierda / Left	176,4 x 44,5 cm	362.002.-.-	362.004.-.-	
			4 Tiroirs / Cajones / Drawers + 2 Portes coulissantes / Puertas correderas / Sliding doors	2 DS / Archivo / File + 2 Portes coulissantes / Puertas correderas / Sliding doors	4 Portes coulissantes / Puertas correderas / Sliding doors
<b>Type 1</b> Tipo 1 Type 1	Double / Doble / Two faces	176,4 x 89 cm	362.010.-.-	362.011.-.-	362.012.-.-
	Individuel / Individual / Single face		2 Tiroirs / Cajones / Drawers + 1 Porte coulissante / Puerta corredera / Sliding door	2 DS / Archivo / File + 1 Porte coulissante / Puerta corredera / Sliding door	2 Portes coulissantes / Puertas correderas / Sliding doors
	À droite / Derecha / Right	176,4 x 44,5 cm	362.030.-.-	362.032.-.-	362.034.-.-
	À gauche / Izquierda / Left	176,4 x 44,5 cm	362.031.-.-	362.033.-.-	
			4 Tiroirs / Cajones / Drawers + 2 Portes coulissantes / Puertas correderas / Sliding doors	2 DS / Archivo / File + 2 Portes coulissantes / Puertas correderas / Sliding doors	4 Portes coulissantes / Puertas correderas / Sliding doors
<b>Type 2</b> Tipo 2 Type 2	Double / Doble / Two faces	176,4 x 89 cm	362.036.-.-	362.037.-.-	362.038.-.-
	Individuel / Individual / Single face		2 Tiroirs / Cajones / Drawers + 1 Porte coulissante / Puerta corredera / Sliding door	2 DS / Archivo / File + 1 Porte coulissante / Puerta corredera / Sliding door	2 Portes coulissantes / Puertas correderas / Sliding doors
	À droite / Derecha / Right	176,4 x 44,5 cm	362.040.-.-	362.042.-.-	362.044.-.-
	À gauche / Izquierda / Left	176,4 x 44,5 cm	362.041.-.-	362.043.-.-	
			4 Tiroirs / Cajones / Drawers + 2 Portes coulissantes / Puertas correderas / Sliding doors	2 DS / Archivo / File + 2 Portes coulissantes / Puertas correderas / Sliding doors	4 Portes coulissantes / Puertas correderas / Sliding doors
<b>Type 3 (avec goulotte)</b> Tipo 3 (con canal electrificación) Type 3 (with cable cover)	Double / Doble / Two faces	176,4 x 89 cm	362.050.-.-	362.051.-.-	362.052.-.-

# MODÈLES | VARIANTES | VERSIONS

## MEUBLES DE RANGEMENT SUPÉRIEURS / ALTILLOS PARA MÓDULOS / HIGH STORAGE

MODÈLE / VARIANTES / VERSIONS	TYPE / TIPO / TYPE	DIMENSIONS / MEDIDAS / MEASUREMENTS	RÉFÉRENCE / REFERENCIA / CODE	
	Individuel / Individual / Single face	176,4 x 34,8 cm	Support ouvert / Soporte abierto / L-Shape supports	Support fermé / Soporte cerrado / U-Shape support
			362.020.-.-	362.021.-.-
	Double / Doble / Two faces	176,4 x 67 cm	362.022.-.-	362.023.-.-

Meubles de rangement supérieurs  
Altillos para módulos  
High storage

# FINITIONS | ACABADOS | FINISHES

## STRUCTURE / ESTRUCTURA / FRAME | PORTES COULISSANTES / PUERTAS CORREDERAS / SLIDING DOORS

Argent Plata Silver	075	Blanc Blanco White	054	Gris Gris Grey	055	Hêtre Haya Beech	061	Chêne Moyen Roble Maple	062	Poirier Peral Pear
	116	Wengué Wengue Wengue	694	Acacia Clair Acacia Clara Light Acacia	695	Acacia Foncé Acacia Oscura Dark Acacia	125	Graphite Grafito Graphite	272	Chêne Veiné Castaño Claro Oak
	273	Chêne Grisé Castaño Oscuro Dark Oak								
Blanc Blanco White	088	Argent Plata Silver	076	Gris Gris Grey	077	Hêtre Haya Beech	078	Chêne Moyen Roble Maple	079	Poirier Peral Pear
	080	Wengué Wengue Wengue	168	Acacia Clair Acacia Clara Light Acacia	169	Acacia Foncé Acacia Oscura Dark Acacia	115	Graphite Grafito Graphite	043	Chêne Veiné Castaño Claro Oak
	106	Chêne Grisé Castaño Oscuro Dark Oak								
Graphite Grafito Graphite	228	Argent Plata Silver	229	Blanc Blanco White	230	Gris Gris Grey	231	Hêtre Haya Beech	232	Chêne Moyen Roble Maple
	234	Poirier Peral Pear	700	Acacia Clair Acacia Clara Light Acacia	701	Acacia Foncé Acacia Oscura Dark Acacia	251	Chêne Veiné Castaño Claro Oak	252	Chêne Grisé Castaño Oscuro Dark Oak
Monochrome Monocolor Single-colour	051	Argent Plata Silver	053	Blanc Blanco White	197	Gris Gris Grey	198	Hêtre Haya Beech	199	Chêne Moyen Roble Maple
	200	Poirier Peral Pear	202	Wengué Wengue Wengue	103	Acacia Clair Acacia Clara Light Acacia	104	Acacia Foncé Acacia Oscura Dark Acacia	204	Graphite Grafito Graphite
	209	Chêne Veiné Castaño Claro Oak	235	Chêne Grisé Castaño Oscuro Dark Oak						

# | COMPLÉMENTS | COMPLEMENTOS | COMPLEMENTS



MODÈLE / VARIANTES / VERSIONS	DIMENSIONS / MEDIDAS / MEASUREMENTS	RÉFÉRENCE / REFERENCIA / CODE			
	Mélangé / Melamina / Melamine	180 cm 160 cm 140 cm	1.351.708.051 1.351.710.051 1.351.712.051	1.351.708.053 1.351.710.053 1.351.712.053	1.351.708.007 1.351.710.007 1.351.712.007
	Métal / Metal / Metal	180 cm 160 cm 140 cm	1.351.723.111 1.351.724.111 1.351.725.111	1.351.723.108 1.351.724.108 1.351.725.108	1.351.723.107 1.351.724.107 1.351.725.107

	Pour bureaux / para mesas / for desks:	180 cm 160 cm 140 cm	Indiv. / Individ. / Single 1.356.303.111 1.356.303.108 1.356.303.107 1.356.304.111 1.356.304.108 1.356.304.107 1.356.305.111 1.356.305.108 1.356.305.107		
	Pour tables de réunion et vis à vis / para mesas de reunión y enfrentadas / for meeting tables and face to face desks	180 cm 160 cm 140 cm	Double / Doble / Double 1.356.313.111 1.356.313.108 1.356.313.107 1.356.314.111 1.356.314.108 1.356.314.107 1.356.315.111 1.356.315.108 1.356.315.107		

# | CLOISONNETTES FRONTALES | PLAFONES | FRONT SCREENS

1 NIVEAU / 1 NIVEL / 1 LEVEL

2 NIVEAUX / 2 NIVELES / 2 LEVELS

MODÈLE / VARIANTES / VERSIONS	L.	RÉFÉRENCE / REFERENCIA / CODE			MODÈLE / VARIANTES / VERSIONS	L.	RÉFÉRENCE / REFERENCIA / CODE				
		RAL 9006	RAL 9016	RAL 7022			RAL 9006	RAL 9016	RAL 7022		
	Indiv. / Individ. / Single	180 cm 160 cm 140 cm	356.054.-.- 356.055.-.- 356.056.-.-	356.154.-.- 356.155.-.- 356.156.-.-		356.254.-.- 356.255.-.- 356.256.-.-	Indiv. / Individ. / Single	180 cm 160 cm 140 cm	356.064.-.- 356.065.-.- 356.066.-.-	356.164.-.- 356.165.-.- 356.166.-.-	356.264.-.- 356.265.-.- 356.266.-.-
Vis à vis / Enfrentadas / Face to face		180 cm 160 cm 140 cm	356.057.-.- 356.058.-.- 356.059.-.-	356.157.-.- 356.158.-.- 356.159.-.-	356.257.-.- 356.258.-.- 356.259.-.-	Vis à vis / Enfrentadas / Face to face		180 cm 160 cm 140 cm	356.067.-.- 356.068.-.- 356.069.-.-	356.167.-.- 356.168.-.- 356.169.-.-	356.267.-.- 356.268.-.- 356.269.-.-

FINITIONS ACABADOS FINISHES		007	Graphite Grafito Graphite	051	Argent Plata Silver
053	Blanc Blanco White	054	Gris Gris Grey	055	Hêtre Haya Beech
061	Chêne Moyen Roble Maple	062	Poirier Peral Pear	116	Wengué Wengue Wengue
103	Acacia Clair Acacia Clara Light Acacia	104	Acacia Foncé Acacia Oscura Dark Acacia	272	Chêne Veiné Castaño Claro Oak
273	Chêne Grisé Castaño Oscuro Dark Oak				

FINITIONS ACABADOS FINISHES		204	Graphite Grafito Graphite	088	Argent Plata Silver
081	Blanc Blanco White	197	Gris Gris Grey	198	Hêtre Haya Beech
199	Chêne Moyen Roble Maple	200	Poirier Peral Pear	202	Wengué Wengue Wengue
103	Acacia Clair Acacia Clara Light Acacia	104	Acacia Foncé Acacia Oscura Dark Acacia	209	Chêne Veiné Castaño Claro Oak
235	Chêne Grisé Castaño Oscuro Dark Oak				

# | FINITIONS | ACABADOS | FINISHES

STRUCTURE / ESTRUCTURA / FRAME

	Argent Plata Silver		Blanc Blanco White		Graphite Grafito Graphite
RAL 9006		RAL 9016		RAL 7022	

# CLOISONNETTES FRONTALES | PLAFONES | FRONT SCREENS

1 NIVEAU / 1 NIVEL / 1 LEVEL

2 NIVEAUX / 2 NIVELES / 2 LEVELS

MODÈLE / VARIANTES / VERSIONS	L.	RÉFÉRENCE / REFERENCIA / CODE			MODÈLE / VARIANTES / VERSIONS	L.	RÉFÉRENCE / REFERENCIA / CODE		
		RAL 9006	RAL 9016	RAL 7022			RAL 9006	RAL 9016	RAL 7022
	Indiv. / Individ. / Single					Indiv. / Individ. / Single			
	180 cm	356.054.000	356.154.000	356.254.000		180 cm	356.064.000	356.164.000	356.264.000
	160 cm	356.055.000	356.155.000	356.255.000		160 cm	356.065.000	356.165.000	356.265.000
	140 cm	356.056.000	356.156.000	356.256.000		140 cm	356.066.000	356.166.000	356.266.000
	Vis à vis / Enfrentadas / Face to face					Vis à vis / Enfrentadas / Face to face			
	180 cm	356.057.000	356.157.000	356.257.000		180 cm	356.067.000	356.167.000	356.267.000
	160 cm	356.058.000	356.158.000	356.258.000		160 cm	356.068.000	356.168.000	356.268.000
	140 cm	356.059.000	356.159.000	356.259.000		140 cm	356.069.000	356.169.000	356.269.000

Tissu  
Tapizado  
Upholstered

Tissu  
Tapizado  
Upholstered

FINITIONS  
ACABADOS  
FINISHES

Cf. page 464  
Ver pagina 464  
See page 464

FINITIONS  
ACABADOS  
FINISHES

Cf. page 464  
Ver pagina 464  
See page 464

	Indiv. / Individ. / Single					Indiv. / Individ. / Single			
	180 cm	356.054.---	356.154.---	356.254.---		180 cm	356.064.---	356.164.---	356.264.---
	160 cm	356.055.---	356.155.---	356.255.---		160 cm	356.065.---	356.165.---	356.265.---
	140 cm	356.056.---	356.156.---	356.256.---		140 cm	356.066.---	356.166.---	356.266.---
	Vis à vis / Enfrentadas / Face to face					Vis à vis / Enfrentadas / Face to face			
	180 cm	356.057.---	356.157.---	356.257.---		180 cm	356.067.---	356.167.---	356.267.---
	160 cm	356.058.---	356.158.---	356.258.---		160 cm	356.068.---	356.168.---	356.268.---
	140 cm	356.059.---	356.159.---	356.259.---		140 cm	356.069.---	356.169.---	356.269.---

Méthacrylate  
Metacrilato  
Methacrylate

Avec méthacrylate et tissu  
Con metacrilato y tapizado  
With methacrylate and  
upholstered

FINITIONS  
ACABADOS  
FINISHES

411 Transparente  
Transparente  
Clear

412 Blanc opaque  
Translúcido  
Translucent

FINITIONS  
ACABADOS  
FINISHES

406 Transparente  
Transparente  
Clear

427 Blanc opaque  
Translúcido  
Translucent

Cf. page 464  
Ver pagina 464  
See page 464

	Indiv. / Individ. / Single					Indiv. / Individ. / Single			
	180 cm	356.081.838	356.181.838	356.281.838		180 cm	356.081.838	356.181.838	356.281.838
	160 cm	356.083.838	356.183.838	356.283.838		160 cm	356.083.838	356.183.838	356.283.838
	140 cm	356.085.838	356.185.838	356.285.838		140 cm	356.085.838	356.185.838	356.285.838
	Vis à vis / Enfrentadas / Face to face					Vis à vis / Enfrentadas / Face to face			
	180 cm	356.091.838	356.191.838	356.291.838		180 cm	356.091.838	356.191.838	356.291.838
	160 cm	356.093.838	356.193.838	356.293.838		160 cm	356.093.838	356.193.838	356.293.838
	140 cm	356.095.838	356.195.838	356.295.838		140 cm	356.095.838	356.195.838	356.295.838

Acoustique  
Acústico  
Acoustic

FINITIONS  
ACABADOS  
FINISHES

Cf. page 464  
Ver pagina 464  
See page 464

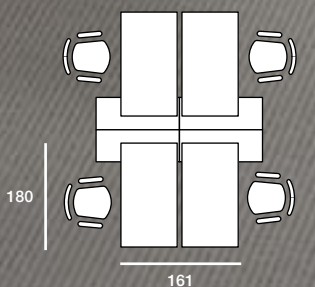

# BORN

Un bureau au style nordique est possible avec la série BORN. Un design pratique et chaleureux qui répond à toutes les exigences pour créer des espaces calmes, ordonnés, propres et fonctionnels.

Una oficina con estilo nórdico es posible con la serie BORN. Un diseño práctico y cálido que reúne todos los requisitos para crear espacios tranquilos, ordenados, limpios y funcionales.



An office with Nordic style is possible with the BORN series. A practical and warm design due to the wooden legs and therefore able to create serene, neat, and useful spaces.

## PLATEAU / SOBRE / DESKTOP

Mélamine / Melamina / Melamine: 25 mm  
Stratifié / Estratificado / Stratified: 13 mm  
10 mm

Chant en ABS / Canto ABS / ABS edges

## STRUCTURE / ESTRUCTURA / FRAME

Bois: 60 x 60 mm - 60 x 30 mm 60   
Madera: 60 x 60 mm - 60 x 30 mm  
Wood:  
Acier: 50 x 30 x 2 mm 50   
Acero: 50 x 30 x 2 mm  
Steel:  
Mixte: 50 x 30 x 2 mm 50   
Mixta: 50 x 30 x 2 mm  
Steel+Wood: 50 x 30 x 2 mm

## FINITION STRUCTURE / ACABADO ESTRUCTURA / FRAME FINISH

Bois ou peinture époxy  
Madera o pintura epoxi  
Wood or epoxy paint

## HAUTEUR / ALTURA / HEIGHT

73 cm

## OPTION / OPCIÓN / OPTION

Voile de fond / Faldón / Modesty panel  
Goulotte / Bandeja electrificación / Cable tray  
Luminaires / Luminarias / Workstation lighting  
Support écran / Soporte pantalla / Monitor holder  
Cloisonnettes / Plafones / Screens

PIEDS  
MÉTALLIQUES

LATERALES  
METÁLICOS

METAL  
FRAME

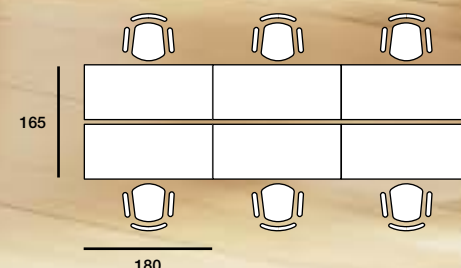
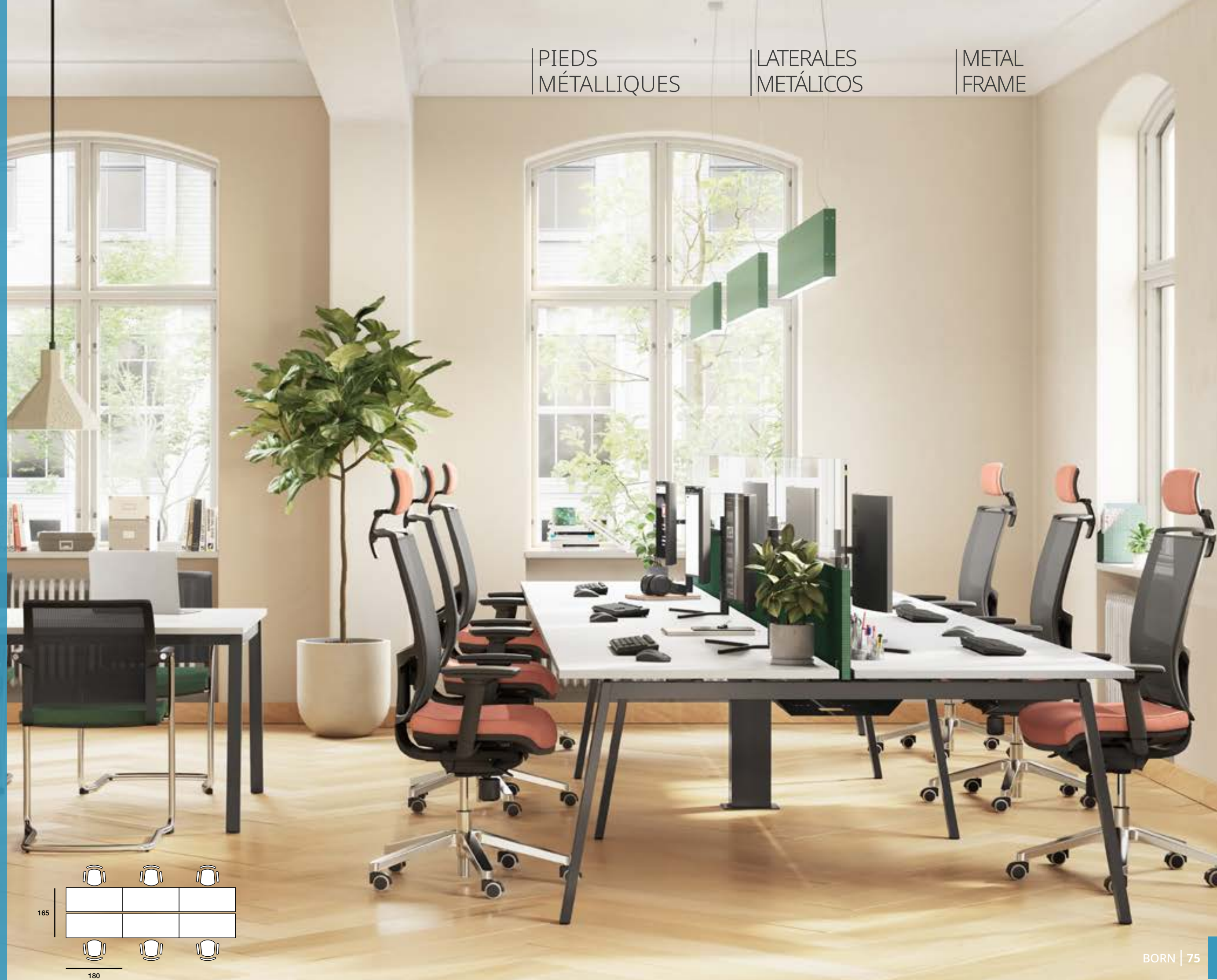



Luminaire pour tables en vis à vis.  
Luminaria para mesas enfrentadas.  
Workstation lighting for face to face desks.

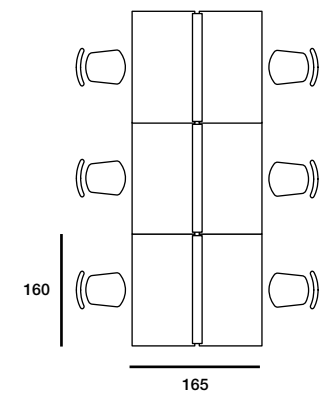

PIEDS  
EN BOIS

LATERALES  
DE MADERA

WOOD  
FRAME

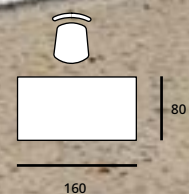

PIEDS  
MÉTAL-BOIS

LATERAL  
METAL-MADERA

METAL-WOOD  
FRAME



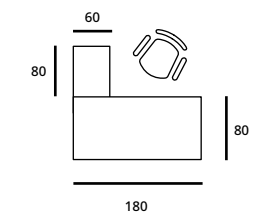



Un autre modèle de design pour la structure.  
Un diseño alternativo para la estructura.  
An alternative design for the frame.





# MODÈLES | VARIANTES | VERSIONS

## STRUCTURE MÉTALLIQUE ET MIXTE / ESTRUCTURA METAL I MIXTA / METAL FRAME AND METAL + WOOD FRAME



MODÈLE / VARIANTES / VERSIONS	TYPE / TIPO / TYPE	DIMENSIONS / MEDIDAS / MEASUREMENTS	RÉFÉRENCE / REFERENCIA / CODE
	Métallique / Metal / Metal	180 x 80 cm 160 x 80 cm 140 x 80 cm	631.102... 631.103... 631.104... 631.202... 631.203... 631.204... 631.302... 631.303... 631.304...
	Mixte / Mixta / Metal + Wood	180 x 80 cm 160 x 80 cm 140 x 80 cm	631.602... 631.603... 631.604... 631.702... 631.703... 631.704... 631.802... 631.803... 631.804...
<b>Bureau individuel / Mesa individual / Individual desks</b>			
	Métallique / Metal / Metal	360 x 165 cm 320 x 165 cm 280 x 165 cm 360 x 125 cm 320 x 125 cm 280 x 125 cm	631.120... 631.121... 631.122... 631.168... 631.169... 631.170... 631.220... 631.221... 631.222... 631.268... 631.269... 631.270... 631.320... 631.321... 631.322... 631.368... 631.369... 631.370...
	Mixte / Mixta / Metal + Wood	360 x 165 cm 320 x 165 cm 280 x 165 cm 360 x 125 cm 320 x 125 cm 280 x 125 cm	631.620... 631.621... 631.622... 631.668... 631.669... 631.670... 631.720... 631.721... 631.722... 631.768... 631.769... 631.770... 631.820... 631.821... 631.822... 631.868... 631.869... 631.870...
<b>Bureaux en vis à vis / Mesas enfrentadas / Face to face desks</b>			
	4 bureaux / mesas / desktops	360 x 165 cm 320 x 165 cm 280 x 165 cm 360 x 125 cm 320 x 125 cm 280 x 125 cm	631.520... 631.521... 631.522... 631.568... 631.569... 631.570...
	2 bureaux / mesas / desktops	180 x 165 cm 160 x 165 cm 140 x 165 cm 180 x 125 cm 160 x 125 cm 140 x 125 cm	631.528... 631.529... 631.530... 631.576... 631.577... 631.578...

# FINITIONS | ACABADOS | FINISHES

## STRUCTURE / ESTRUCTURA / FRAME | PLATEAU / SOBRE / DESKTOP

 Argent Plata Silver RAL 9006	 Argent + Hêtre Plata + Haya Silver + Beech veneer	 Blanc Blanco White	 Gris Gris Grey	 Hêtre Haya Beech
 Blanc Blanco White RAL 9016	 Blanc + Hêtre Blanco + Haya White + Beech veneer	 Chêne Moyen Roble Maple	 Poirier Peral Pear	 Wengué Wengue Wengue
 Graphite Grafito Graphite RAL 7022	 Graphite + Hêtre Grafito + Haya Graphite + Beech veneer	 Acacia Clair Acacia Clara Light Acacia	 Acacia Foncé Acacia Oscura Dark Acacia	 Graphite Grafito Graphite
		 Chêne Veiné Castaño Claro Oak	 Chêne Grisé Castaño Oscuro Dark Oak	

## STRUCTURE EN BOIS / ESTRUCTURA MADERA / WOOD FRAME

MODÈLE / VARIANTES / VERSIONS	TYPE / TIPO / TYPE	DIMENSIONS / MEDIDAS / MEASUREMENTS	RÉFÉRENCE / REFERENCIA / CODE
		180 x 80 cm 160 x 80 cm 140 x 80 cm	631.502... 631.503... 631.504...
<b>Bureau individuel / Mesa individual / Individual desks</b>			
	4 bureaux / mesas / desktops	360 x 165 cm 320 x 165 cm 280 x 165 cm 360 x 125 cm 320 x 125 cm 280 x 125 cm	631.520... 631.521... 631.522... 631.568... 631.569... 631.570...
	2 bureaux / mesas / desktops	180 x 165 cm 160 x 165 cm 140 x 165 cm 180 x 125 cm 160 x 125 cm 140 x 125 cm	631.528... 631.529... 631.530... 631.576... 631.577... 631.578...
<b>Bureaux en vis à vis / Mesas enfrentadas / Face to face desks</b>			

# FINITIONS | ACABADOS | FINISHES

## STRUCTURE / ESTRUCTURA / FRAME | PLATEAU / SOBRE / DESKTOP

 Hêtre Haya Beech veneer	 053 Blanc Blanco White	 054 Gris Gris Grey	 055 Hêtre Haya Beech	 061 Chêne Moyen Roble Maple
	 062 Poirier Peral Pear	 116 Wengué Wengue Wengue	 103 Acacia Clair Acacia Clara Light Acacia	 104 Acacia Foncé Acacia Oscura Dark Acacia
	 007 Graphite Grafito Graphite	 272 Chêne Veiné Castaño Claro Oak	 273 Chêne Grisé Castaño Oscuro Dark Oak	

# COMPLÉMENTS | COMPLEMENTOS | COMPLEMENTS

MODÈLE / VARIANTES / VERSIONS	DIMENSIONS / MEDIDAS / MEASUREMENTS	RÉFÉRENCE / REFERENCIA / CODE		
	120 x 60 cm 80 x 60 cm	631.191.-... 631.190.-...	631.291.-... 631.290.-...	631.391.-... 631.390.-...
	120 x 60 cm 80 x 60 cm	631.691.-... 631.690.-...	631.791.-... 631.790.-...	631.891.-... 631.890.-...
	120 x 60 cm 80 x 60 cm			631.591.-... 631.590.-...
<b>Retour secrétaire</b> <b>Ala taquígrafa</b> <b>Return</b>				
	80 x 40 cm	631.197.-...	631.297.-...	631.397.-...
<b>Demi-rond</b> <b>Semicircular</b> <b>Semicircular</b>				
	165 x 70 cm	631.198.-...	631.298.-...	631.398.-...
<b>Demi-rond - Bureaux en vis à vis</b> <b>Semicircular - Mesas enfrentadas</b> <b>Semicircular - Face to face desks</b>				
	165 x 40 cm	631.199.-...	631.299.-...	631.399.-...
<b>Semi-elliptique - Bureaux en vis à vis</b> <b>Semielliptico - Mesas enfrentadas</b> <b>Semielliptic - Face to face desks</b>				

# FINITIONS | ACABADOS | FINISHES

STRUCTURE / ESTRUCTURA / FRAME | PLATEAU / SOBRE / DESKTOP

	Argent Plata Silver		Argent + Hêtre Plata + Haya Silver + Beech veneer		Hêtre Haya Beech veneer
	Blanc Blanco White		Blanc + Hêtre Blanco + Haya White + Beech veneer		Blanc Blanco White
	Graphite Grafito Graphite		Graphite + Hêtre Grafito + Haya Graphite + Beech veneer		Gris Gris Grey
			Hêtre Haya Beech		Chêne Moyen Roble Maple
			Poirier Peral Pear		Wengué Wengue Wengue
			Acacia Clair Acacia Clara Light Acacia		Acacia Foncé Acacia Oscura Dark Acacia
			Graphite Grafito Graphite		Chêne Veiné Castaño Claro Oak
			Chêne Gris Castaño Oscuro Dark Oak		

# COMPLÉMENTS | COMPLEMENTOS | COMPLEMENTS

MODÈLE / VARIANTES / VERSIONS	TYPE / TIPO / TYPE	DIMENSIONS / MEDIDAS / MEASUREMENTS	RÉFÉRENCE / REFERENCIA / CODE		
	Mélamine / Melamina / Melamine	180 cm 160 cm 140 cm	1.351.706.051 1.351.708.051 1.351.710.051	1.351.706.053 1.351.708.053 1.351.710.053	1.351.706.007 1.351.708.007 1.351.710.007
<b>Voiles de fond</b> <b>Faldones</b> <b>Modesty panels</b>					
	Métal / Metal / Metal	180 cm 160 cm 140 cm	1.351.722.111 1.351.723.111 1.351.724.111	1.351.722.108 1.351.723.108 1.351.724.108	1.351.722.107 1.351.723.107 1.351.724.107
<b>Voiles de fond</b> <b>Faldones</b> <b>Modesty panels</b>					
	Pour bureaux / para mesas / for desks:	180 cm 160 cm 140 cm	1.356.302.111 1.356.303.111 1.356.304.111	1.356.302.108 1.356.303.108 1.356.304.108	1.356.302.107 1.356.303.107 1.356.304.107
<b>Indiv. / Individ. / Single</b>					
	Pour tables de réunion et bureaux en vis à vis / para mesas de reunión y enfrentadas / for meeting tables and face to face desks	250 / 200 cm 160 cm 150 / 140 cm 120 cm	1.636.312.111 1.636.313.111 1.636.314.111 1.636.315.111	1.636.312.108 1.636.313.108 1.636.314.108 1.636.315.108	1.636.312.301 1.636.313.301 1.636.314.301 1.636.315.301
<b>Double / Doble / Double</b>					
<b>Goulotte</b> <b>Bandeja electrificación</b> <b>Cable tray</b>					
	Pour structure métallique et mixte / para estructura metal i mixta / for metal frame and metal + wood frame	180 cm 160 cm 140 cm	638.801.111 638.802.111 638.803.111	638.801.108 638.802.108 638.803.108	638.801.107 638.802.107 638.803.107
<b>Pour structure en bois / para estructura madera / for wood frame</b>					
	Pour structure en bois / para estructura madera / for wood frame	180 cm 160 cm 140 cm	638.811.111 638.812.111 638.813.111	638.811.108 638.812.108 638.813.108	638.811.107 638.812.107 638.813.107
<b>Luminaires pour tables en vis à vis</b> <b>Luminarias para mesas enfrentadas</b> <b>Workstation lighting</b>					

	1 Rallonge connexion au mur / 1 latiguillo de conexión a pared / Fast cable connexion to wall socket	200 cm	446.991.000	446.992.000	446.995.000
--	--	--------	-------------	-------------	-------------

**Rallonge connexion**  
**Latiguillo de conexión**  
**Cable connexion**

# FINITIONS | ACABADOS | FINISHES

STRUCTURE / ESTRUCTURA / FRAME

	Argent Plata Silver		Blanc Blanco White		Graphite Grafito Graphite
--	---------------------------	--	--------------------------	--	---------------------------------



# | COMPLÉMENTS | COMPLEMENTOS | COMPLEMENTS

MODÈLE / VARIANTES / VERSIONS	TYPE / TIPO / TYPE	RÉFÉRENCE / REFERENCIA / CODE	
	Individuel / Individual / Single	 <b>846.693.111</b>	 <b>846.693.108</b>
	Double / Doble / Double	<b>846.694.111</b>	<b>846.694.108</b>

**Support écran**  
**SopORTE pantalla**  
**Monitor holder**

# | FINITIONS | ACABADOS | FINISHES

## STRUCTURE / ESTRUCTURA / FRAME

 Argent Plata Silver <small>RAL 9006</small>	 Blanc Blanco White <small>RAL 9016</small>
--	---

# | CLOISONNETTES FRONTALES | PLAFONES | FRONT SCREENS

## 1 NIVEAU / 1 NIVEL / 1 LEVEL

MODÈLE / VARIANTES / VERSIONS	L.	RÉFÉRENCE / REFERENCIA / CODE		
		 <small>RAL 9006</small>	 <small>RAL 9016</small>	 <small>RAL 7022</small>
	180 cm	<b>356.007.-..</b>	<b>356.107.-..</b>	<b>356.207.-..</b>
	160 cm	<b>356.008.-..</b>	<b>356.108.-..</b>	<b>356.208.-..</b>
	140 cm	<b>356.009.-..</b>	<b>356.109.-..</b>	<b>356.209.-..</b>

**Mélamine**  
**Melamina**  
**Melamine**

## 2 NIVEAUX / 2 NIVELES / 2 LEVELS

MODÈLE / VARIANTES / VERSIONS	L.	RÉFÉRENCE / REFERENCIA / CODE		
		 <small>RAL 9006</small>	 <small>RAL 9016</small>	 <small>RAL 7022</small>
	180 cm	<b>356.021.-..</b>	<b>356.121.-..</b>	<b>356.221.-..</b>
	160 cm	<b>356.022.-..</b>	<b>356.122.-..</b>	<b>356.222.-..</b>
	140 cm	<b>356.023.-..</b>	<b>356.123.-..</b>	<b>356.223.-..</b>





**Mélamine**  
**Melamina**  
**Melamine**

FINITIONS ACABADOS FINISHES		FINITIONS ACABADOS FINISHES	
<b>007</b> Graphite Grafito Graphite	<b>051</b> Argent Plata Silver	<b>053</b> Blanc Blanco White	<b>054</b> Gris Gris Grey
<b>061</b> Chêne Moyen Roble Maple	<b>062</b> Poirier Peral Pear	<b>055</b> Hêtre Haya Beech	<b>116</b> Wengué Wengue Wengue
<b>103</b> Acacia Clair Acacia Clara Light Acacia	<b>104</b> Acacia Foncé Acacia Oscura Dark Acacia	<b>272</b> Chêne Veiné Castaño Claro Oak	<b>273</b> Chêne Grisé Castaño Oscuro Dark Oak

FINITIONS ACABADOS FINISHES		FINITIONS ACABADOS FINISHES	
<b>204</b> Graphite Grafito Graphite	<b>088</b> Argent Plata Silver	<b>081</b> Blanc Blanco White	<b>197</b> Gris Gris Grey
<b>199</b> Chêne Moyen Roble Maple	<b>200</b> Poirier Peral Pear	<b>198</b> Hêtre Haya Beech	<b>202</b> Wengué Wengue Wengue
<b>103</b> Acacia Clair Acacia Clara Light Acacia	<b>104</b> Acacia Foncé Acacia Oscura Dark Acacia	<b>209</b> Chêne Veiné Castaño Claro Oak	<b>235</b> Chêne Grisé Castaño Oscuro Dark Oak

# | CLOISONNETTES FRONTALES | PLAFONES | FRONT SCREENS





## 1 NIVEAU / 1 NIVEL / 1 LEVEL

MODÈLE / VARIANTES / VERSIONS	L.	RÉFÉRENCE / REFERENCIA / CODE		
		 <small>RAL 9006</small>	 <small>RAL 9016</small>	 <small>RAL 7022</small>
	180 cm	<b>356.007.000</b>	<b>356.107.000</b>	<b>356.207.000</b>
	160 cm	<b>356.008.000</b>	<b>356.108.000</b>	<b>356.208.000</b>
	140 cm	<b>356.009.000</b>	<b>356.109.000</b>	<b>356.209.000</b>

**Tissu**  
**Tapizado**  
**Upholstered**





**FINITIONS ACABADOS FINISHES** Cf. page 464  
Ver pagina 464  
See page 464

## 2 NIVEAUX / 2 NIVELES / 2 LEVELS

MODÈLE / VARIANTES / VERSIONS	L.	RÉFÉRENCE / REFERENCIA / CODE		
		 <small>RAL 9006</small>	 <small>RAL 9016</small>	 <small>RAL 7022</small>
	180 cm	<b>356.021.000</b>	<b>356.121.000</b>	<b>356.221.000</b>
	160 cm	<b>356.022.000</b>	<b>356.122.000</b>	<b>356.222.000</b>
	140 cm	<b>356.023.000</b>	<b>356.123.000</b>	<b>356.223.000</b>





**Tissu**  
**Tapizado**  
**Upholstered**

**FINITIONS ACABADOS FINISHES** Cf. page 464  
Ver pagina 464  
See page 464

MODÈLE / VARIANTES / VERSIONS	L.	RÉFÉRENCE / REFERENCIA / CODE		
		 <small>RAL 9006</small>	 <small>RAL 9016</small>	 <small>RAL 7022</small>
	180 cm	<b>356.007.-..</b>	<b>356.107.-..</b>	<b>356.207.-..</b>
	160 cm	<b>356.008.-..</b>	<b>356.108.-..</b>	<b>356.208.-..</b>
	140 cm	<b>356.009.-..</b>	<b>356.109.-..</b>	<b>356.209.-..</b>

**Méthacrylate**  
**Metacrilato**  
**Methacrylate**

**FINITIONS ACABADOS FINISHES** **411** Transparent  
Transparente  
Clear **412** Blanc opaque  
Translúcido  
Translucent

MODÈLE / VARIANTES / VERSIONS	L.	RÉFÉRENCE / REFERENCIA / CODE		
		 <small>RAL 9006</small>	 <small>RAL 9016</small>	 <small>RAL 7022</small>
	180 cm	<b>356.021.-..</b>	<b>356.121.-..</b>	<b>356.221.-..</b>
	160 cm	<b>356.022.-..</b>	<b>356.122.-..</b>	<b>356.222.-..</b>
	140 cm	<b>356.023.-..</b>	<b>356.123.-..</b>	<b>356.223.-..</b>

**Avec méthacrylate et tissu**  
**Con metacrilato y tapizado**  
**With methacrylate and upholstered**

**FINITIONS ACABADOS FINISHES** **406** Transparent  
Transparente  
Clear **427** Blanc opaque  
Translúcido  
Translucent Cf. page 464  
Ver pagina 464  
See page 464

# tempo

Polyvalence et lignes épurées sont les principales caractéristiques de cette série. Elle nous permet de créer des espaces de travail avec une apparence légère et simple.

Versatilidad y simplicidad de formas son las características principales de esta serie. Se consiguen espacios diversos con formas ligeras y simples.

Versatility and simplicity on shapes are the main features of this range. Create different working spaces with light and simple looking.

## PLATEAU / SOBRE / DESK TOP

Mélamine / Melamina / Melamine: 25 mm  
Chant en ABS / Canto ABS / ABS edges

## STRUCTURE / ESTRUCTURA / FRAME

Acier: 55 mm x 55 mm x 1,5 mm   
Steel: 55 mm x 55 mm x 1,5 mm

## FINITION STRUCTURE / ACABADO ESTRUCTURA / FRAME FINISH

Peinture époxy  
Pintura epoxi  
Epoxy paint

## HAUTEUR / ALTURA / HEIGHT

Fixe: 73 cm Réglable: 80,6 > 63 cm  
Fija: 73 cm Regulable: 80,6 > 63 cm  
Fixed: 73 cm Adjustable: 80,6 > 63 cm

## OPTION / OPCIÓN / OPTION

Voile de fond / Faldón / Modesty panel  
Goulotte / Bandeja electrificación / Cable tray  
Cloisonnettes / Plafones / Screens

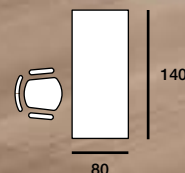

BUREAU  
INDIVIDUEL

MESA  
INDIVIDUAL

INDIVIDUAL  
DESK



BUREAUX  
EN VIS À VIS  
AVEC CRÉDENCE

MESAS  
ENFRENTADAS  
CON CREDENCIA

FACE TO FACE  
DESKS WITH  
SIDE CREDENZA

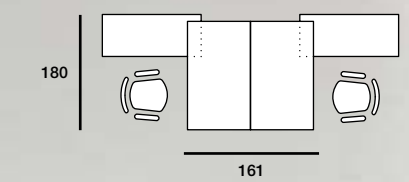

BUREAUX EN  
VIS À VIS  
AVEC RETOUR

MESAS  
ENFRENTADAS  
CON ALA

FACE TO  
FACE DESKS  
WITH RETURN

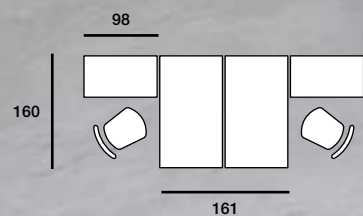

BUREAUX  
EN VIS À VIS



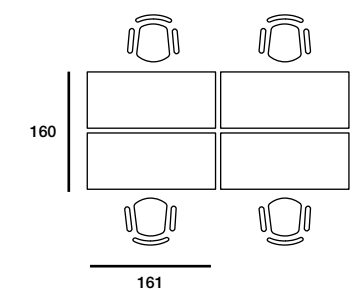

MESAS  
ENFRENTADAS

FACE TO  
FACE DESKS





Combinable avec caissons et crédences OH-SYSTEMS.  
Combinable con cajoneras y credencias OH-SYSTEMS.  
Combine with OH-SYSTEMS pedestals and credenzas.



# MODÈLES | VARIANTES | VERSIONS

MODÈLE / VARIANTES / VERSIONS	TYPE / TIPO / TYPE	DIMENSIONS / MEDIDAS / MEASUREMENTS	RÉFÉRENCE / REFERENCIA / CODE	
		180 x 80 cm	H. fixe / fija / fixed	H. réglable / regulable / adjustable
		160 x 80 cm	381.301.-.-	381.401.-.-
		140 x 80 cm	381.302.-.-	381.402.-.-
		120 x 80 cm	381.303.-.-	381.403.-.-
		80 x 80 cm	381.304.-.-	381.404.-.-
<b>Bureau individuel</b> Mesa individual Individual desks				
		180 x 80 cm	À droite / Derecha / Right	À gauche / Izquierda / Left
		160 x 80 cm	381.381.-.-	381.382.-.-
		140 x 80 cm	381.383.-.-	381.384.-.-
			381.385.-.-	381.386.-.-
<b>Bureau individuel pour crédence</b> Mesa individual con credencia Individual desks with side credenza				
		360 x 80 cm	H. fixe / fija / fixed	H. réglable / regulable / adjustable
		320 x 80 cm	381.318.-.-	381.418.-.-
		280 x 80 cm	381.319.-.-	381.419.-.-
		240 x 80 cm	381.320.-.-	381.420.-.-
			381.321.-.-	381.421.-.-
<b>Bureaux alignés</b> Mesas lineales Side by side desks				
	4 bureaux / mesas / desktops	360 x 161 cm	H. fixe / fija / fixed	H. réglable / regulable / adjustable
		320 x 161 cm	381.362.-.-	381.462.-.-
		280 x 161 cm	381.363.-.-	381.463.-.-
		240 x 161 cm	381.364.-.-	381.464.-.-
	2 bureaux / mesas / desktops	180 x 161 cm	381.365.-.-	381.465.-.-
		160 x 161 cm	381.366.-.-	381.466.-.-
		140 x 161 cm	381.367.-.-	381.467.-.-
		120 x 161 cm	381.368.-.-	381.468.-.-
			381.369.-.-	381.469.-.-
<b>Bureaux en vis à vis</b> Mesas enfrentadas Face to face desks				
	4 bureaux / mesas / desktops	360 x 161 cm	H. fixe / fija / fixed	
		320 x 161 cm	381.388.-.-	
		280 x 161 cm	381.389.-.-	
	2 bureaux / mesas / desktops	180 x 161 cm	381.391.-.-	
		160 x 161 cm	381.392.-.-	
		140 x 161 cm	381.393.-.-	
<b>Bureaux en vis à vis pour crédence</b> Mesas enfrentadas con credencia Face to face desks with side credenza				

# COMPLÉMENTS | COMPLEMENTOS | COMPLEMENTS







MODÈLE / VARIANTES / VERSIONS	DIMENSIONS / MEDIDAS / MEASUREMENTS	RÉFÉRENCE / REFERENCIA / CODE													
	120 x 98 cm 98 x 60 cm	H. fixe / fija / fixed	H. réglable / regulable / adjustable												
		381.329.-.-	381.429.-.-												
<b>Retour secrétaire</b> Ala taquígrafa Return															
	158 x 118 cm	H. fixe / fija / fixed	H. réglable / regulable / adjustable												
		381.330.-.-	381.430.-.-												
<b>Exécutif</b> Ejecutivo Teardrop															
	161 x 70 cm	H. fixe / fija / fixed	H. réglable / regulable / adjustable												
		381.331.-.-	381.431.-.-												
<b>Demi-rond</b> Semicircular Semicircular															
	161 x 40 cm	H. fixe / fija / fixed	H. réglable / regulable / adjustable												
		381.332.-.-	381.432.-.-												
<b>Semi-elliptique</b> Semielíptico Semielliptic															
	123 X 78,3 cm	H. fixe / fija / fixed													
		1.381.033.-.-													
<b>Angle concave 90°</b> Ángulo cóncavo 90° 90° Concave angle															
<b>FINITIONS ACABADOS FINISHES</b> <table border="0"> <tr> <td>053 Blanc Blanco White</td> <td>054 Gris Gris Grey</td> <td>055 Hêtre Haya Beech</td> <td>061 Chêne Moyen Roble Maple</td> </tr> <tr> <td>062 Poirier Peral Pear</td> <td>063 Wengué Wengue Wengue</td> <td>103 Acacia Clair Acacia Clara Light Acacia</td> <td>104 Acacia Foncé Acacia Oscura Dark Acacia</td> </tr> <tr> <td>007 Graphite Grafito Graphite</td> <td>272 Chêne Veiné Castaño Claro Oak</td> <td>273 Chêne Grisé Castaño Oscuro Dark Oak</td> <td></td> </tr> </table>				053 Blanc Blanco White	054 Gris Gris Grey	055 Hêtre Haya Beech	061 Chêne Moyen Roble Maple	062 Poirier Peral Pear	063 Wengué Wengue Wengue	103 Acacia Clair Acacia Clara Light Acacia	104 Acacia Foncé Acacia Oscura Dark Acacia	007 Graphite Grafito Graphite	272 Chêne Veiné Castaño Claro Oak	273 Chêne Grisé Castaño Oscuro Dark Oak	
053 Blanc Blanco White	054 Gris Gris Grey	055 Hêtre Haya Beech	061 Chêne Moyen Roble Maple												
062 Poirier Peral Pear	063 Wengué Wengue Wengue	103 Acacia Clair Acacia Clara Light Acacia	104 Acacia Foncé Acacia Oscura Dark Acacia												
007 Graphite Grafito Graphite	272 Chêne Veiné Castaño Claro Oak	273 Chêne Grisé Castaño Oscuro Dark Oak													



# FINITIONS | ACABADOS | FINISHES

STRUCTURE / ESTRUCTURA / FRAME | PLATEAU / SOBRE / DESK TOP

Argent Plata Silver RAL 9006	060 Blanc Blanco White	064 Gris Gris Grey	065 Hêtre Haya Beech	066 Chêne Moyen Roble Maple	067 Poirier Peral Pear	068 Wengué Wengue Wengue
	706 Acacia Clair Acacia Clara Light Acacia	707 Acacia Foncé Acacia Oscura Dark Acacia	020 Graphite Grafito Graphite	031 Chêne Veiné Castaño Claro Oak	032 Chêne Grisé Castaño Oscuro Dark Oak	
Blanc Blanco White RAL 9016	096 Blanc Blanco White	097 Gris Gris Grey	098 Hêtre Haya Beech	099 Chêne Moyen Roble Maple	100 Poirier Peral Pear	101 Wengué Wengue Wengue
	709 Acacia Clair Acacia Clara Light Acacia	710 Acacia Foncé Acacia Oscura Dark Acacia	017 Graphite Grafito Graphite	166 Chêne Veiné Castaño Claro Oak	167 Chêne Grisé Castaño Oscuro Dark Oak	
Graphite Grafito Graphite RAL 7022	163 Blanc Blanco White	180 Gris Gris Grey	181 Hêtre Haya Beech	182 Chêne Moyen Roble Maple	183 Poirier Peral Pear	184 Wengué Wengue Wengue
	715 Acacia Clair Acacia Clara Light Acacia	716 Acacia Foncé Acacia Oscura Dark Acacia	113 Graphite Grafito Graphite	206 Chêne Veiné Castaño Claro Oak	208 Chêne Grisé Castaño Oscuro Dark Oak	

# COMPLÉMENTS | COMPLEMENTOS | COMPLEMENTS



MODÈLE / VARIANTES / VERSIONS	DIMENSIONS / MEDIDAS / MEASUREMENTS	RÉFÉRENCE / REFERENCIA / CODE	
 Mélangine / Melamina / Melamine	180 cm 160 cm 140 cm 120 cm Angle 90° / Ángulo 90° / 90° angle 80 cm	 441.602.051  441.603.051  441.604.051  441.605.051  441.606.051  441.607.051	
<b>Voiles de fond</b> <b>Faldones</b> <b>Modesty panels</b>	Métal / Metal / Metal	180 cm 160 cm 140 cm 120 cm 80 cm	441.702.111 441.703.111 441.704.111 441.705.111 441.706.111

MODÈLE / VARIANTES / VERSIONS	DIMENSIONS / MEDIDAS / MEASUREMENTS	RÉFÉRENCE / REFERENCIA / CODE	
 Pour bureaux / para mesas / for desks:	220 cm 200 cm 180 cm 160 cm 140 cm 120 cm 80 cm	Indiv. / Individ. / Single 1.386.300.111 1.386.301.111 1.386.302.111 1.386.303.111 1.386.304.111 1.386.305.111 1.386.307.111	1.386.300.108 1.386.301.108 1.386.302.108 1.386.303.108 1.386.304.108 1.386.305.108 1.386.307.108
 Pour tables de réunion et vis à vis / Para mesas de reunión y enfrentadas / For meeting tables and face to face desks	250 cm 200 cm 180 cm 150 / 160 cm 140 cm 120 cm 80 cm	Double / Doble / Double 1.386.310.111 1.386.311.111 1.386.312.111 1.386.313.111	1.386.310.108 1.386.311.108 1.386.312.108 1.386.313.108

**Goulotte**  
**Bandeja electrificación**  
**Cable tray**

# FINITIONS | ACABADOS | FINISHES

## STRUCTURE / ESTRUCTURA / FRAME

 Argent Plata Silver	 Blanc Blanco White	 Graphite Grafito Graphite
---	--	---

# CLOISONNETTES FRONTALES | PLAFONES | FRONT SCREENS



## 1 NIVEAU / 1 NIVEL / 1 LEVEL

MODÈLE / VARIANTES / VERSIONS	L	RÉFÉRENCE / REFERENCIA / CODE
		 PINCES / PINZAS / BRACKET RAL 9006  RAL 9016  RAL 7022
Indiv. / Individ. / Single Vis à vis / Enfrentadas / Face to face		180 cm 386.008.--- 386.108.--- 386.208.--- 160 cm 386.009.--- 386.109.--- 386.209.--- 140 cm 386.010.--- 386.110.--- 386.210.--- 120 cm 386.011.--- 386.111.--- 386.211.--- 80 cm 386.013.--- 386.113.--- 386.213.---

Mélangine  
Melamina  
Melamine

FINITIONS ACABADOS FINISHES	007	051	088
Graphite Grafito Graphite	Argent Plata Silver		
053 Blanc Blanco White	054 Gris Gris Grey	055 Hêtre Haya Beech	
061 Chêne Moyen Roble Maple	062 Poirier Peral Pear	116 Wengé Wengue Wengue	
103 Acacia Clair Acacia Clara Light Acacia	104 Acacia Foncé Acacia Oscura Dark Acacia	272 Chêne Veiné Castaño Claro Oak	
273 Chêne Gris Castaño Oscuro Dark Oak			

## 2 NIVEAUX / 2 NIVELES / 2 LEVELS

MODÈLE / VARIANTES / VERSIONS	L	RÉFÉRENCE / REFERENCIA / CODE
		 PINCES / PINZAS / BRACKET RAL 9006  RAL 9016  RAL 7022
Indiv. / Individ. / Single Vis à vis / Enfrentadas / Face to face		180 cm 386.021.--- 386.121.--- 386.221.--- 160 cm 386.022.--- 386.122.--- 386.222.--- 140 cm 386.023.--- 386.123.--- 386.223.--- 120 cm 386.024.--- 386.124.--- 386.224.--- 80 cm 386.026.--- 386.126.--- 386.226.---

Mélangine  
Melamina  
Melamine

FINITIONS ACABADOS FINISHES	204	088	088
Graphite Grafito Graphite	Argent Plata Silver		
081 Blanc Blanco White	197 Gris Gris Grey	198 Hêtre Haya Beech	
199 Chêne Moyen Roble Maple	200 Poirier Peral Pear	202 Wengé Wengue Wengue	
103 Acacia Clair Acacia Clara Light Acacia	104 Acacia Foncé Acacia Oscura Dark Acacia	209 Chêne Veiné Castaño Claro Oak	
235 Chêne Gris Castaño Oscuro Dark Oak			

MODÈLE / VARIANTES / VERSIONS	L	RÉFÉRENCE / REFERENCIA / CODE
		Indiv. / Individ. / Single Vis à vis / Enfrentadas / Face to face 180 cm 386.008.000 386.108.000 386.208.000 160 cm 386.009.000 386.109.000 386.209.000 140 cm 386.010.000 386.110.000 386.210.000 120 cm 386.011.000 386.111.000 386.211.000 80 cm 386.013.000 386.113.000 386.213.000

Tissu Tapizado Upholstered

FINITIONS ACABADOS FINISHES  
Cf. page 464 Ver pagina 464 See page 464

MODÈLE / VARIANTES / VERSIONS	L	RÉFÉRENCE / REFERENCIA / CODE
		Indiv. / Individ. / Single Vis à vis / Enfrentadas / Face to face 180 cm 386.021.000 386.121.000 386.221.000 160 cm 386.022.000 386.122.000 386.222.000 140 cm 386.023.000 386.123.000 386.223.000 120 cm 386.024.000 386.124.000 386.224.000 80 cm 386.026.000 386.126.000 386.226.000

Tissu Tapizado Upholstered

FINITIONS ACABADOS FINISHES  
Cf. page 464 Ver pagina 464 See page 464

MODÈLE / VARIANTES / VERSIONS	L	RÉFÉRENCE / REFERENCIA / CODE
		Indiv. / Individ. / Single Vis à vis / Enfrentadas / Face to face 180 cm 386.008.--- 386.108.--- 386.208.--- 160 cm 386.009.--- 386.109.--- 386.209.--- 140 cm 386.010.--- 386.110.--- 386.210.--- 120 cm 386.011.--- 386.111.--- 386.211.--- 80 cm 386.013.--- 386.113.--- 386.213.---

Méthacrylate Metacrilato Methacrylate

MODÈLE / VARIANTES / VERSIONS	L	RÉFÉRENCE / REFERENCIA / CODE
		Indiv. / Individ. / Single Vis à vis / Enfrentadas / Face to face 180 cm 386.021.--- 386.121.--- 386.221.--- 160 cm 386.022.--- 386.122.--- 386.222.--- 140 cm 386.023.--- 386.123.--- 386.223.--- 120 cm 386.024.--- 386.124.--- 386.224.--- 80 cm 386.026.--- 386.126.--- 386.226.---

Avec méthacrylate et tissu Con metacrilato y tapizado With methacrylate and upholstered

FINITIONS ACABADOS FINISHES	411	412
Transparent Transparente Clear	Blanc opaque Translúcido Transparent	

FINITIONS ACABADOS FINISHES	406	427
Transparent Transparente Clear	Blanc opaque Translúcido Transparent	

Cf. page 464 Ver pagina 464 See page 464



# ECO

ECO, une série modulaire et polyvalente résolument adaptée aux besoins du marché.

Culminación de esfuerzos encaminados a satisfacer las necesidades de trabajo más exigentes.

This range is the result of many efforts seeking to meet the most demanding working needs from the simplicity of shapes and design.

## PLATEAU / SOBRE / DESK TOP

Mélamine / Melamina / Melamine:  
Stratifié / Estratificado / Stratified: 25 mm

Chant en ABS / Canto ABS / ABS edges

## STRUCTURE / ESTRUCTURA / FRAME

Acier  
Acero  
Steel 60 x 60 x 2 mm



## FINITION STRUCTURE / ACABADO ESTRUCTURA / FRAME FINISH

Peinture époxy  
Pintura epoxi  
Epoxy paint

## HAUTEUR / ALTURA / HEIGHT

73 cm

## OPTION / OPCIÓN / OPTION

Voile de fond / Faldón / Modesty panel  
Goulotte / Bandeja electrificación / Cable tray  
Cloisonnettes / Plafones / Screens

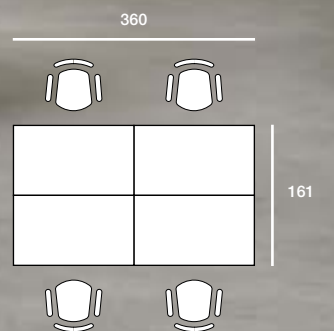

BUREAUX EN  
VIS À VIS

MESAS  
ENFRENTADAS

FACE TO FACE  
DESKS



BUREAUX  
INDIVIDUELS

MESAS  
INDIVIDUALES

INDIVIDUAL  
DESKS

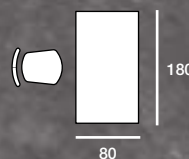

BUREAUX EN  
VIS À VIS AVEC  
CRÉDENCE

MESAS  
ENFRENTADAS  
CON CREDENCIA

FACE TO FACE  
DESKS WITH  
SIDE CREDENZA

Combinable avec caissons et crédences OH-SYSTEMS.  
Combinable con cajoneras y credencias OH-SYSTEMS.  
Combine with OH-SYSTEMS pedestals and credenzas.

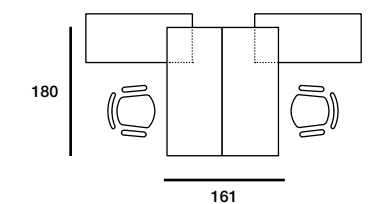





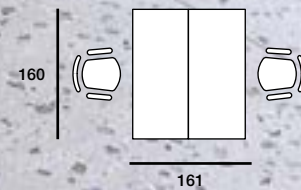

BUREAUX EN  
VIS À VIS AVEC  
ORGATOWER

MESAS  
ENFRENTADAS  
CON ORGATOWER





FACE TO FACE  
DESKS WITH  
ORGATOWER



# MODÈLES | VARIANTES | VERSIONS

MODÈLE / VARIANTES / VERSIONS	TYPE / TIPO / TYPE	DIMENSIONS / MEDIDAS / MEASUREMENTS	RÉFÉRENCE / REFERENCIA / CODE
 <p>Bureau individuel Mesa individual Individual desks</p>		220 x 100 cm 200 x 100 cm	391.931.-.- 391.932.-.-
		180 x 80 cm 160 x 80 cm 140 x 80 cm 120 x 80 cm 80 x 80 cm	391.901.-.- 391.902.-.- 391.903.-.- 391.904.-.- 391.905.-.-
 <p>Bureau individuel pour crédence Mesa individual con credencia Individual desks with side credenza</p>		180 x 80 cm 160 x 80 cm 140 x 80 cm	391.906.-.- 391.908.-.- 391.910.-.-
			391.907.-.- 391.909.-.- 391.911.-.-
 <p>Bureaux en vis à vis Mesas enfrentadas Face to face desks</p>	4 bureaux / mesas / desktops	360 x 161 cm 320 x 161 cm 280 x 161 cm 200 x 161 cm	391.962.-.- 391.963.-.- 391.964.-.- 391.965.-.-
	2 bureaux / mesas / desktops	180 x 161 cm 160 x 161 cm 140 x 161 cm 100 x 161 cm	391.966.-.- 391.967.-.- 391.968.-.- 391.969.-.-
 <p>Bureaux en vis à vis pour crédence Mesas enfrentadas para credencia Face to face desks with side credenza</p>	4 bureaux / mesas / desktops	360 x 161 cm 320 x 161 cm 280 x 161 cm	391.934.-.- 391.935.-.- 391.936.-.-
	2 bureaux / mesas / desktops	180 x 161 cm 160 x 161 cm 140 x 161 cm	391.937.-.- 391.938.-.- 391.939.-.-

# COMPLÉMENTS | COMPLEMENTOS | COMPLEMENTS

MODÈLE / VARIANTES / VERSIONS	DIMENSIONS / MEDIDAS / MEASUREMENTS	RÉFÉRENCE / REFERENCIA / CODE
 <p>Retour secrétaire Ala taquígrafa Return</p>	98 x 60 cm	Droite / Derecha / Right Gauche / Izquierda / Left 391.915.-.- 391.916.-.-
 <p>Exécutif Ejecutivo Teardrop</p>	158 x 118 cm	391.925.-.-
 <p>Demi-rond Semicircular Semicircular</p>	161 x 70 cm	391.019.-.-
 <p>Semi-elliptique Semielliptico Semielliptic</p>	161 x 40 cm	391.022.-.-
 <p>Angle concave 90° Ángulo cóncavo 90° 90° Concave angle</p>	123 X 78,3 cm	441.017.-.-

**FINITIONS  
ACABADOS  
FINISHES**

053 Blanc Blanco White	054 Gris Gris Grey	055 Hêtre Haya Beech	061 Chêne Moyen Roble Maple
062 Poirier Peral Pear	063 Wengué Wengue Wengue	103 Acacia Clair Acacia Clara Light Acacia	104 Acacia Foncé Acacia Oscura Dark Acacia
007 Graphite Grafito Graphite	272 Chêne Veiné Castaño Claro Oak	273 Chêne Grisé Castaño Oscuro Dark Oak	

# FINITIONS | ACABADOS | FINISHES

STRUCTURE / ESTRUCTURA / FRAME | PLATEAU / SOBRE / DESK TOP

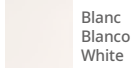
 <p>RAL 9006 Argent Plata Silver</p>	060 Blanc Blanco White	064 Gris Gris Grey	065 Hêtre Haya Beech	066 Chêne Moyen Roble Maple	067 Poirier Peral Pear
	068 Wengué Wengue Wengue	706 Acacia Clair Acacia Clara Light Acacia	707 Acacia Foncé Acacia Oscura Dark Acacia	020 Graphite Grafito Graphite	031 Chêne Veiné Castaño Claro Oak
	032 Chêne Grisé Castaño Oscuro Dark Oak				
 <p>Blanc Blanco White</p> <p>RAL 9016</p>	096 Blanc Blanco White	097 Gris Gris Grey	098 Hêtre Haya Beech	099 Chêne Moyen Roble Maple	100 Poirier Peral Pear
	101 Wengué Wengue Wengue	709 Acacia Clair Acacia Clara Light Acacia	710 Acacia Foncé Acacia Oscura Dark Acacia	017 Graphite Grafito Graphite	166 Chêne Veiné Castaño Claro Oak
	167 Chêne Grisé Castaño Oscuro Dark Oak				

# COMPLÉMENTS | COMPLEMENTOS | COMPLEMENTS

MODÈLE / VARIANTES / VERSIONS	DIMENSIONS / MEDIDAS / MEASUREMENTS	RÉFÉRENCE / REFERENCIA / CODE		
 Voiles de fond Faldones Modesty panels	Mélamine / Melamina / Melamine	220 cm 200 cm 180 cm 160 cm 140 cm 120 cm Angle 90° / Ángulo 90° / 90° angle 80 cm	441.600.051 441.601.051 441.602.051 441.603.051 441.604.051 441.605.051 441.618.051 441.606.051	441.600.053 441.601.053 441.602.053 441.603.053 441.604.053 441.605.053 441.618.053 441.606.053
	Métal / Metal / Metal	220 cm 200 cm 180 cm 160 cm 140 cm 120 cm 80 cm	441.700.111 441.701.111 441.702.111 441.703.111 441.704.111 441.705.111 441.706.111	441.700.108 441.701.108 441.702.108 441.703.108 441.704.108 441.705.108 441.706.108

MODÈLE / VARIANTES / VERSIONS	DIMENSIONS / MEDIDAS / MEASUREMENTS	RÉFÉRENCE / REFERENCIA / CODE		
 Goulotte Bandeja electrificación Cable tray	Pour tables de réunion et bureaux en vis à vis / para mesas de reunión y enfrentadas / for meeting tables and face to face desks	250 cm 200 cm 180 cm 150 / 160 cm 140 cm 120 cm 80 cm	1.386.310.111 1.386.311.111 1.386.312.111 1.386.313.111	1.386.310.108 1.386.311.108 1.386.312.108 1.386.313.108
	Double / Doble / Double	250 cm 200 cm 180 cm 150 / 160 cm 140 cm 120 cm 80 cm	1.386.310.111 1.386.311.111 1.386.312.111 1.386.313.111	1.386.310.108 1.386.311.108 1.386.312.108 1.386.313.108

# FINITIONS | ACABADOS | FINISHES

## STRUCTURE / ESTRUCTURA / FRAME

	Argent Plata Silver		Blanc Blanco White
RAL 9006		RAL 9016	

# CLOISONNETTES FRONTALES | PLAFONES | FRONT SCREENS

## 1 NIVEAU / 1 NIVEL / 1 LEVEL

MODÈLE / VARIANTES / VERSIONS	L.	RÉFÉRENCE / REFERENCIA / CODE
 Mélamine Melamina Melamine	Indiv. / Indiv. / Single	PINCES / PINZAS / BRACKET RAL 9006 RAL 9016 386.008.-.- 386.108.-.- 386.009.-.- 386.109.-.- 386.010.-.- 386.110.-.- 386.011.-.- 386.111.-.- 386.013.-.- 386.113.-.-
	Vis à vis / Enfrentadas / Face to face	
	180 cm	
	160 cm	
	140 cm	
	120 cm	
	80 cm	

FINITIONS ACABADOS FINISHES	204	Graphite Grafito Graphite	088	Argent Plata Silver	
081	Blanc Blanco White	197	Gris Gris Grey	198	Hêtre Haya Beech
199	Chêne Moyen Roble Maple	200	Poirier Peral Pear	202	Wengué Wengue Wengue
103	Acacia Clair Acacia Clara Light Acacia	104	Acacia Foncé Acacia Oscura Dark Acacia	209	Chêne Veiné Castaño Claro Oak
235	Chêne Grisé Castaño Oscuro Dark Oak				

## 2 NIVEAUX / 2 NIVELES / 2 LEVELS

MODÈLE / VARIANTES / VERSIONS	L.	RÉFÉRENCE / REFERENCIA / CODE
 Mélamine Melamina Melamine	Indiv. / Indiv. / Single	PINCES / PINZAS / BRACKET RAL 9006 RAL 9016 386.021.-.- 386.121.-.- 386.022.-.- 386.122.-.- 386.023.-.- 386.123.-.- 386.024.-.- 386.124.-.- 386.026.-.- 386.126.-.-
	Vis à vis / Enfrentadas / Face to face	
	180 cm	
	160 cm	
	140 cm	
	120 cm	
	80 cm	

FINITIONS ACABADOS FINISHES	204	Graphite Grafito Graphite	088	Argent Plata Silver	
081	Blanc Blanco White	197	Gris Gris Grey	198	Hêtre Haya Beech
199	Chêne Moyen Roble Maple	200	Poirier Peral Pear	202	Wengué Wengue Wengue
103	Acacia Clair Acacia Clara Light Acacia	104	Acacia Foncé Acacia Oscura Dark Acacia	209	Chêne Veiné Castaño Claro Oak
235	Chêne Grisé Castaño Oscuro Dark Oak				

MODÈLE / VARIANTES / VERSIONS	L.	RÉFÉRENCE / REFERENCIA / CODE
 Tissu Tapizado Upholstered	Indiv. / Indiv. / Single	386.008.000 386.108.000 386.009.000 386.109.000 386.010.000 386.110.000 386.011.000 386.111.000 386.013.000 386.113.000
	Vis à vis / Enfrentadas / Face to face	
	180 cm	
	160 cm	
	140 cm	
	120 cm	
	80 cm	

FINITIONS ACABADOS FINISHES	Page 464
	Cf. page 464 Ver pagina 464 See page 464

MODÈLE / VARIANTES / VERSIONS	L.	RÉFÉRENCE / REFERENCIA / CODE
 Tissu Tapizado Upholstered	Indiv. / Indiv. / Single	386.021.000 386.121.000 386.022.000 386.122.000 386.023.000 386.123.000 386.024.000 386.124.000 386.026.000 386.126.000
	Vis à vis / Enfrentadas / Face to face	
	180 cm	
	160 cm	
	140 cm	
	120 cm	
	80 cm	

FINITIONS ACABADOS FINISHES	Page 464
	Cf. page 464 Ver pagina 464 See page 464

MODÈLE / VARIANTES / VERSIONS	L.	RÉFÉRENCE / REFERENCIA / CODE
 Méthacrylate Metacrilato Methacrylate	Indiv. / Indiv. / Single	386.008.-.- 386.108.-.- 386.009.-.- 386.109.-.- 386.010.-.- 386.110.-.- 386.011.-.- 386.111.-.- 386.013.-.- 386.113.-.-
	Vis à vis / Enfrentadas / Face to face	
	180 cm	
	160 cm	
	140 cm	
	120 cm	
	80 cm	

FINITIONS ACABADOS FINISHES	411	Transparent Transparente Clear	412	Blanc opaque Translúcido Translucent
-----------------------------	-----	--------------------------------	-----	--------------------------------------

MODÈLE / VARIANTES / VERSIONS	L.	RÉFÉRENCE / REFERENCIA / CODE
 Avec méthacrylate et tissu Con metacrilato y tapizado With methacrylate and upholstered	Indiv. / Indiv. / Single	386.021.-.- 386.121.-.- 386.022.-.- 386.122.-.- 386.023.-.- 386.123.-.- 386.024.-.- 386.124.-.- 386.026.-.- 386.126.-.-
	Vis à vis / Enfrentadas / Face to face	
	180 cm	
	160 cm	
	140 cm	
	120 cm	
	80 cm	

FINITIONS ACABADOS FINISHES	406	Transparent Transparente Clear	427	Blanc opaque Translúcido Translucent
-----------------------------	-----	--------------------------------	-----	--------------------------------------

OPÉRATIF  
OPERATIVAS  
INDIVIDUAL DESKS



**108** | SIGMA



**122** | TONO



**134** | ROCK 3

# sigma

SIGMA améliore votre poste de travail grâce à ses nouveaux concepts ergonomiques et esthétiques.

SIGMA mejora los puestos de trabajo aportándoles nuevos conceptos ergonómicos y estéticos.

SIGMA improves workplaces by its ergonomics features and design concepts.

## PLATEAU / SOBRE / DESK TOP

Mélamine / Melamina / Melamine: 25 mm  
Chant en ABS / Canto ABS / ABS edges

## STRUCTURE / ESTRUCTURA / FRAME

Acier: 65 x 74 x 1,5 mm  
Acero:  
Steel:



\* Montée de câbles intégrée / Subida de cables integrada / Cable management built-in frame

## FINITION STRUCTURE / ACABADO ESTRUCTURA / FRAME FINISH

Peinture époxy  
Pintura epoxi  
Epoxy paint

## HAUTEUR / ALTURA / HEIGHT

Fixe:	Réglable:
Fija:	Regulable:
Fixed:	Adjustable:

73 cm      81,5> 63,5 cm

## OPTION / OPCIÓN / OPTION

Cloisonnettes / Plafones / Screens

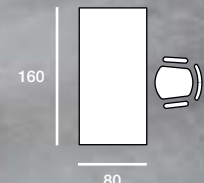

BUREAU  
INDIVIDUEL

MESA  
INDIVIDUAL

INDIVIDUAL  
DESK

POSTE  
COMPACT  
SYMÉTRIQUE

PUESTO  
COMPACTO  
SIMÉTRICO

SYMMETRIC  
L-SHAPED  
DESK



Piédement métallique à dégagement latéral avec passage de câbles intégré.  
Lateral en forma de "L" con pasa cables integrado.  
L-shape frame with cable management cover.

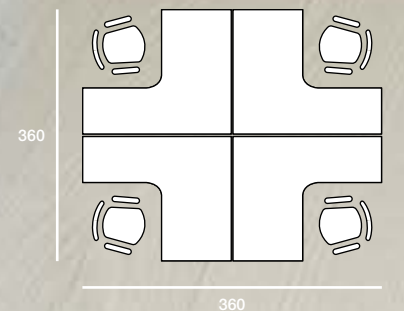





| POSTE  
| COMPACT  
| ÉXÉCUTIF

| PUESTO  
| COMPACTO  
| EJECUTIVO

| EXECUTIVE  
| DESK

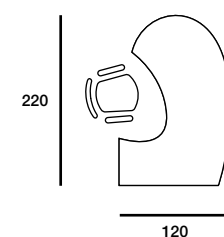



BANQUES  
D'ACCUEIL

MOSTRADORES

COUNTERS FOR  
TABLE TOPS

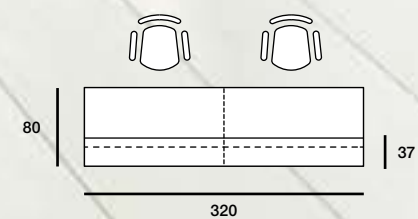

Rehausse d'accueil optionnelle.

Una opción fácil para resolver un puesto de atención al cliente.













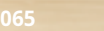
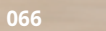





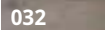

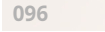
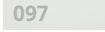



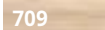

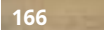
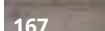

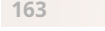
An easy way to solve a customer service corner.

# MODÈLES | VARIANTES | VERSIONS

MODÈLE / VARIANTES / VERSIONS	TYPE / TIPO / TYPE	DIMENSIONS / MEDIDAS / MEASUREMENTS	RÉFÉRENCE / REFERENCIA / CODE	
 Bureau individuel Mesa individual Rectangular desks	Coins droits / Cantos rectos / Square edges	180 x 80 cm 160 x 80 cm 140 x 80cm 120 x 80cm 80 x 80cm	231.102.-.- 231.103.-.- 231.104.-.- 231.105.-.- 231.107.-.-	
	Coins arrondis / Cantos redondos / Round edges	180 x 80 cm 160 x 80 cm 140 x 80cm 120 x 80cm 80 x 80cm	231.402.-.- 231.403.-.- 231.404.-.- 231.405.-.- 231.407.-.-	
			Droit / Derecha / Right	Gauche / Izquierda / Left
 Bureau onde Mesa ola Wave shape desks	Coins droits / Cantos rectos / Square edges	180 x 100 - 80 cm 160 x 100 - 80 cm 140 x 100 - 80 cm	231.132.-.- 231.133.-.- 231.134.-.- 231.135.-.- 231.136.-.- 231.137.-.-	
	Coins arrondis / Cantos redondos / Round edges	180 x 100 - 80 cm 160 x 100 - 80 cm 140 x 100 - 80 cm	231.422.-.- 231.423.-.- 231.424.-.- 231.425.-.- 231.426.-.- 231.427.-.-	
			Droit / Derecha / Right	Gauche / Izquierda / Left
 Poste compact exécutif Compacto ejecutivo Executive desks	Coins droits / Cantos rectos / Square edges	220 x 120 cm 200 x 120 cm	231.690.-.- 231.691.-.- 231.692.-.- 231.693.-.-	
			Droit / Derecha / Right	Gauche / Izquierda / Left
 Poste compact VII Compacto VII L-shaped desks VII	Coins droits / Cantos rectos / Square edges	L. 180 cm 180 x 160 cm 180 x 140 cm 180 x 120 cm	231.730.-.- 231.731.-.- 231.732.-.- 231.733.-.- 231.734.-.- 231.735.-.-	
		L. 160 cm 160 x 160 cm 160 x 140 cm 160 x 120 cm	231.750.-.- 231.751.-.- 231.752.-.- 231.753.-.- 231.754.-.- 231.755.-.-	
 Poste compact VIII Compacto VIII L-shaped desks VIII	Coins droits / Cantos rectos / Square edges	160 x 160 cm 140 x 140 cm	231.712.-.- 231.714.-.-	
	Coins arrondis / Cantos redondos / Round edges	160 x 160 cm 140 x 140 cm	231.904.-.- 231.906.-.-	
 Poste compact symétrique Compacto simétrico L-shaped symmetrical desks	Coins droits / Cantos rectos / Square edges	180 x 180 cm 160 x 160 cm 140 x 140 cm	231.670.-.- 231.671.-.- 231.672.-.-	
	Coins arrondis / Cantos redondos / Round edges	180 x 180 cm 160 x 160 cm 140 x 140 cm	231.880.-.- 231.882.-.- 231.884.-.-	

# FINITIONS | ACABADOS | FINISHES

STRUCTURE / ESTRUCTURA / FRAME | PLATEAU / SOBRE / DESK TOP

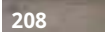
 Argent Plata Silver RAL 9006	 Blanc Blanco White	 Gris Gris Grey	 Hêtre Haya Beech	 Chêne Moyen Roble Maple	 Poirier Peral Pear
	 Wengué Wengue Wengue	 Acacia Clair Acacia Clara Light Acacia	 Acacia Foncé Acacia Oscura Dark Acacia	 Graphite Grafito Graphite	 Chêne Veiné Castaño Claro Oak
	 Chêne Grisé Castaño Oscuro Dark Oak				
 Blanc Blanco White RAL 9016	 Blanc Blanco White	 Gris Gris Grey	 Hêtre Haya Beech	 Chêne Moyen Roble Maple	 Poirier Peral Pear
	 Wengué Wengue Wengue	 Acacia Clair Acacia Clara Light Acacia	 Acacia Foncé Acacia Oscura Dark Acacia	 Graphite Grafito Graphite	 Chêne Veiné Castaño Claro Oak
	 Chêne Grisé Castaño Oscuro Dark Oak				
 Graphite Grafito Graphite RAL 7022	 Blanc Blanco White	 Gris Gris Grey	 Hêtre Haya Beech	 Chêne Moyen Roble Maple	 Poirier Peral Pear
	 Wengué Wengue Wengue	 Acacia Clair Acacia Clara Light Acacia	 Acacia Foncé Acacia Oscura Dark Acacia	 Graphite Grafito Graphite	 Chêne Veiné Castaño Claro Oak
	 Chêne Grisé Castaño Oscuro Dark Oak				

# COMPLÉMENTS | COMPLEMENTOS | COMPLEMENTS

MODÈLE / VARIANTES / VERSIONS	DIMENSIONS / MEDIDAS / MEASUREMENTS	RÉFÉRENCE / REFERENCIA / CODE
 <p>Retour secrétaire Ala taquígrafa Return</p>	Coins droits / Cantos rectos / Square edges	98 X 60 cm
	Coins arrondis / Cantos redondos / Round edges	98 X 60 cm
	- Pour bureaux onde / Para mesas ola / For wave desks:	
	Coins droits / Cantos rectos / Square edges	82,8 X 60 cm
	Coins arrondis / Cantos redondos / Round edges	82,8 X 60 cm

MODÈLE / VARIANTES / VERSIONS	DIMENSIONS / MEDIDAS / MEASUREMENTS	RÉFÉRENCE / REFERENCIA / CODE
 <p>Convivialité Gota ejecutiva Teardrop</p>	118 x 158 cm	231.325.---

MODÈLE / VARIANTES / VERSIONS	DIMENSIONS / MEDIDAS / MEASUREMENTS	RÉFÉRENCE / REFERENCIA / CODE
 <p>Demi-rond Semicircular Semicircular</p>	80 x 40 cm	231.324.---

MODÈLE / VARIANTES / VERSIONS	DIMENSIONS / MEDIDAS / MEASUREMENTS	RÉFÉRENCE / REFERENCIA / CODE
 <p>Demi-rond entre 2 bureaux Semicircular para 2 mesas Semicircular for two desks</p>	161 x 70 cm	231.326.---

MODÈLE / VARIANTES / VERSIONS	DIMENSIONS / MEDIDAS / MEASUREMENTS	RÉFÉRENCE / REFERENCIA / CODE
 <p>Semi-elliptique Semielíptico Semielliptic</p>	161 x 40 cm	231.327.---

MODÈLE / VARIANTES / VERSIONS	DIMENSIONS / MEDIDAS / MEASUREMENTS	RÉFÉRENCE / REFERENCIA / CODE
 <p>Angle concave 90° Ángulo cóncavo 90° 90° Concave angle</p>	80 x 80 cm	421.016.---

## FINITIONS ACABADOS FINISHES

053	Blanc Blanco White	054	Gris Gris Grey	055	Hêtre Haya Beech	061	Chêne Moyen Roble Maple
062	Poirier Peral Pear	063	Wengué Wengue Wengue	103	Acacia Clair Acacia Clara Light Acacia	104	Acacia Foncé Acacia Oscura Dark Acacia
007	Graphite Grafito Graphite	272	Chêne Veiné Castaño Claro Oak	273	Chêne Grisé Castaño Oscuro Dark Oak		

MODÈLE / VARIANTES / VERSIONS	DIMENSIONS / MEDIDAS / MEASUREMENTS	RÉFÉRENCE / REFERENCIA / CODE
 <p>Bureau secrétaire Mesa taquígrafa Shorthand desk</p>	110 x 60 cm	231.304.---

MODÈLE / VARIANTES / VERSIONS	DIMENSIONS / MEDIDAS / MEASUREMENTS	RÉFÉRENCE / REFERENCIA / CODE
 <p>Banques d'accueil Mostradores Counters for table top</p>	180 x 37 cm 160 x 37 cm 140 x 37 cm 120 x 37 cm 80 x 37 cm 117 x 47,3 cm ( angle 90° / ángulo 90° / 90° angle)	1.233.004.--- 1.233.006.--- 1.233.008.--- 1.233.010.--- 1.233.012.--- 1.233.020.---

## FINITIONS ACABADOS FINISHES

053	Blanc Blanco White	054	Gris Gris Grey	055	Hêtre Haya Beech	061	Chêne Moyen Roble Maple
062	Poirier Peral Pear	063	Wengué Wengue Wengue	103	Acacia Clair Acacia Clara Light Acacia	104	Acacia Foncé Acacia Oscura Dark Acacia
007	Graphite Grafito Graphite	272	Chêne Veiné Castaño Claro Oak	273	Chêne Grisé Castaño Oscuro Dark Oak		

# FINITIONS | ACABADOS | FINISHES

## STRUCTURE / ESTRUCTURA / FRAME

## PLATEAU / SOBRE / DESK TOP

Argent Plata Silver RAL 9006	060	Blanc Blanco White	064	Gris Gris Grey	065	Hêtre Haya Beech	066	Chêne Moyen Roble Maple	067	Poirier Peral Pear
	068	Wengué Wengue Wengue	706	Acacia Clair Acacia Clara Light Acacia	707	Acacia Foncé Acacia Oscura Dark Acacia	020	Graphite Grafito Graphite	031	Chêne Veiné Castaño Claro Oak
	032	Chêne Grisé Castaño Oscuro Dark Oak								
	096	Blanc Blanco White	097	Gris Gris Grey	098	Hêtre Haya Beech	099	Chêne Moyen Roble Maple	100	Poirier Peral Pear
Blanc Blanco White RAL 9016	101	Wengué Wengue Wengue	709	Acacia Clair Acacia Clara Light Acacia	710	Acacia Foncé Acacia Oscura Dark Acacia	017	Graphite Grafito Graphite	166	Chêne Veiné Castaño Claro Oak
	167	Chêne Grisé Castaño Oscuro Dark Oak								
	163	Blanc Blanco White	180	Gris Gris Grey	181	Hêtre Haya Beech	182	Chêne Moyen Roble Maple	183	Poirier Peral Pear
Graphite Grafito Graphite RAL 7022	184	Wengué Wengue Wengue	715	Acacia Clair Acacia Clara Light Acacia	716	Acacia Foncé Acacia Oscura Dark Acacia	113	Graphite Grafito Graphite	206	Chêne Veiné Castaño Claro Oak
	208	Chêne Grisé Castaño Oscuro Dark Oak								

# CLOISONNETTES FRONTALES | PLAFONES | FRONT SCREENS

1 NIVEAU / 1 NIVEL / 1 LEVEL

2 NIVEAUX / 2 NIVELES / 2 LEVELS

MODÈLE / VARIANTES / VERSIONS	L.	RÉFÉRENCE / REFERENCIA / CODE	MODÈLE / VARIANTES / VERSIONS	L.	RÉFÉRENCE / REFERENCIA / CODE
-------------------------------	----	-------------------------------	-------------------------------	----	-------------------------------

MODÈLE / VARIANTES / VERSIONS	L.	RÉFÉRENCE / REFERENCIA / CODE
	180 cm	386.008.--- 386.108.--- 386.208.---
	160 cm	386.009.--- 386.109.--- 386.209.---
	140 cm	386.010.--- 386.110.--- 386.210.---
	120 cm	386.011.--- 386.111.--- 386.211.---
	100 cm	386.012.--- 386.112.--- 386.212.---
	80 cm	386.013.--- 386.113.--- 386.213.---

Mélamine  
Melamina  
Melamine

MODÈLE / VARIANTES / VERSIONS	L.	RÉFÉRENCE / REFERENCIA / CODE
	180 cm	386.021.--- 386.121.--- 386.221.---
	160 cm	386.022.--- 386.122.--- 386.222.---
	140 cm	386.023.--- 386.123.--- 386.223.---
	120 cm	386.024.--- 386.124.--- 386.224.---
	100 cm	386.025.--- 386.125.--- 386.225.---
	80 cm	386.026.--- 386.126.--- 386.226.---

Mélamine  
Melamina  
Melamine

## FINITIONS ACABADOS FINISHES

<b>007</b>	Graphite Grafito Graphite	<b>051</b>	Argent Plata Silver
<b>053</b>	Blanc Blanco White	<b>054</b>	Gris Gris Grey
<b>061</b>	Chêne Moyen Roble Maple	<b>062</b>	Poirier Peral Pear
<b>103</b>	Acacia Clair Acacia Clara Light Acacia	<b>104</b>	Acacia Foncé Acacia Oscura Dark Acacia
<b>273</b>	Chêne Grisé Castaño Oscuro Dark Oak	<b>116</b>	Wengué Wengue Wengue
		<b>272</b>	Chêne Veiné Castaño Claro Oak

## FINITIONS ACABADOS FINISHES

<b>204</b>	Graphite Grafito Graphite	<b>088</b>	Argent Plata Silver
<b>081</b>	Blanc Blanco White	<b>197</b>	Gris Gris Grey
<b>199</b>	Chêne Moyen Roble Maple	<b>200</b>	Poirier Peral Pear
<b>103</b>	Acacia Clair Acacia Clara Light Acacia	<b>104</b>	Acacia Foncé Acacia Oscura Dark Acacia
<b>235</b>	Chêne Grisé Castaño Oscuro Dark Oak	<b>202</b>	Wengué Wengue Wengue
		<b>209</b>	Chêne Veiné Castaño Claro Oak

MODÈLE / VARIANTES / VERSIONS	L.	RÉFÉRENCE / REFERENCIA / CODE
	180 cm	386.008.000 386.108.000 386.208.000
	160 cm	386.009.000 386.109.000 386.209.000
	140 cm	386.010.000 386.110.000 386.210.000
	120 cm	386.011.000 386.111.000 386.211.000
	100 cm	386.012.000 386.112.000 386.212.000
	80 cm	386.013.000 386.113.000 386.213.000

Tissu  
Tapizado  
Upholstered

MODÈLE / VARIANTES / VERSIONS	L.	RÉFÉRENCE / REFERENCIA / CODE
	180 cm	386.021.000 386.121.000 386.221.000
	160 cm	386.022.000 386.122.000 386.222.000
	140 cm	386.023.000 386.123.000 386.223.000
	120 cm	386.024.000 386.124.000 386.224.000
	100 cm	386.025.000 386.125.000 386.225.000
	80 cm	386.026.000 386.126.000 386.226.000

Tissu  
Tapizado  
Upholstered

## FINITIONS ACABADOS FINISHES

Cf. page 464  
Ver pagina 464  
See page 464

## FINITIONS ACABADOS FINISHES

Cf. page 464  
Ver pagina 464  
See page 464

MODÈLE / VARIANTES / VERSIONS	L.	RÉFÉRENCE / REFERENCIA / CODE
	180 cm	386.008.--- 386.108.--- 386.208.---
	160 cm	386.009.--- 386.109.--- 386.209.---
	140 cm	386.010.--- 386.110.--- 386.210.---
	120 cm	386.011.--- 386.111.--- 386.211.---
	100 cm	386.012.--- 386.112.--- 386.212.---
	80 cm	386.013.--- 386.113.--- 386.213.---

Méthacrylate  
Metacrilato  
Methacrylate

MODÈLE / VARIANTES / VERSIONS	L.	RÉFÉRENCE / REFERENCIA / CODE
	180 cm	386.021.--- 386.121.--- 386.221.---
	160 cm	386.022.--- 386.122.--- 386.222.---
	140 cm	386.023.--- 386.123.--- 386.223.---
	120 cm	386.024.--- 386.124.--- 386.224.---
	100 cm	386.025.--- 386.125.--- 386.225.---
	80 cm	386.026.--- 386.126.--- 386.226.---

Avec méthacrylate et tissu  
Con metacrilato y tapizado  
With methacrylate and upholstered

## FINITIONS ACABADOS FINISHES

**411** Transparent  
Transparente  
Clear

**412** Blanc opaque  
Translúcido  
Translucent

## FINITIONS ACABADOS FINISHES

**406** Transparent  
Transparente  
Clear

**427** Blanc opaque  
Translúcido  
Translucent

Cf. page 464  
Ver pagina 464  
See page 464



180

80

# tono

Large éventail de styles et compositions  
avec un minimum de références.

Con esta serie se obtiene una gran versatilidad  
de estilos y composiciones  
con un número reducido de referencias.

Great variety of styles and compositions within  
the same range and easy to order.

## PLATEAU / SOBRE / DESK TOP

Mélamine / Melamina / Melamine: 25 mm

Chant en ABS / Canto ABS / ABS edges

## STRUCTURE / ESTRUCTURA / FRAME

Acier	6,5 cm	Mélamine	2,5 cm
Acero	75 cm	Melamina	67,5 cm
Steel		Melamine	

\* Montée de câbles intégrée uniquement pour T2 / Subida de cables integrada para T2 / Cable management built-in frame for T2

## STRUCTURE EN ACIER / ESTRUCTURA ACERO / STEEL FRAME

Peinture époxy  
Pintura epoxi  
Epoxy paint

## HAUTEUR / ALTURA / HEIGHT

73 cm

## OPTION / OPCIÓN / OPTION

Cloisonnettes / Plafones / Screens



BUREAU  
INDIVIDUEL

MESA  
INDIVIDUAL

INDIVIDUAL  
DESK

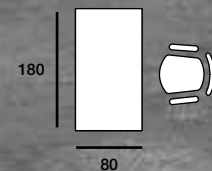

POSTE COMPACT  
ÉXÉCUTIF

COMPACTO  
EJECUTIVO

EXECUTIVE  
DESK



POSTE  
COMPACT

PUESTO  
COMPACTO

L-SHAPED  
DESKS



Passe-câbles extractible.  
Perfil de subida de cables.  
Cable beam.

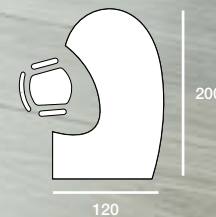
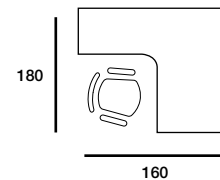

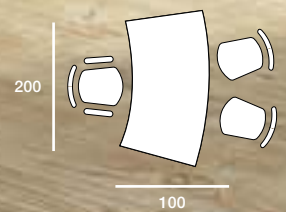

| BUREAU IV

| FORMA IV

| IV SHAPE



## MODÈLES | VARIANTES | VERSIONS

T3

MODÈLE / VARIANTES / VERSIONS	DIMENSIONS / MEDIDAS / MEASUREMENTS	RÉFÉRENCE / REFERENCIA / CODE												
Bureau individuel IV Forma IV Shaped desk (IV)	200 x 100 cm	601.107.-.-												
<b>FINITIONS ACABADOS FINISHES</b> <table border="0"> <tr> <td>053 Blanc Blanco White</td> <td>197 Gris Gris Grey</td> <td>198 Hêtre Haya Beech</td> <td>199 Chêne Moyen Roble Maple</td> </tr> <tr> <td>200 Poirier Peral Pear</td> <td>202 Wengué Wengue Wengue</td> <td>103 Acacia Clair Acacia Clara Light Acacia</td> <td>104 Acacia Foncé Acacia Oscura Dark Acacia</td> </tr> <tr> <td>007 Graphite Grafito Graphite</td> <td>209 Chêne Veiné Castaño Claro Oak</td> <td>235 Chêne Grisè Castaño Oscuro Dark Oak</td> <td></td> </tr> </table>			053 Blanc Blanco White	197 Gris Gris Grey	198 Hêtre Haya Beech	199 Chêne Moyen Roble Maple	200 Poirier Peral Pear	202 Wengué Wengue Wengue	103 Acacia Clair Acacia Clara Light Acacia	104 Acacia Foncé Acacia Oscura Dark Acacia	007 Graphite Grafito Graphite	209 Chêne Veiné Castaño Claro Oak	235 Chêne Grisè Castaño Oscuro Dark Oak	
053 Blanc Blanco White	197 Gris Gris Grey	198 Hêtre Haya Beech	199 Chêne Moyen Roble Maple											
200 Poirier Peral Pear	202 Wengué Wengue Wengue	103 Acacia Clair Acacia Clara Light Acacia	104 Acacia Foncé Acacia Oscura Dark Acacia											
007 Graphite Grafito Graphite	209 Chêne Veiné Castaño Claro Oak	235 Chêne Grisè Castaño Oscuro Dark Oak												
Bureau individuel Mesa individual Rectangular desks	180 x 80 cm 160 x 80 cm 140 x 80 cm 120 x 80 cm 100 x 80 cm 80 x 80 cm	601.101.-.- 601.102.-.- 601.103.-.- 601.104.-.- 601.105.-.- 601.106.-.-												
Poste compact B Compacto B L-shape desk B	180 x 120 cm 160 x 120 cm	Droit / Derecha / Right 601.320.-.- 601.322.-.- Gauche / Izquierda / Left 601.321.-.- 601.323.-.-												
Poste compact C Compacto C L-shaped desk C	180 x 160 cm 160 x 160 cm	Droit / Derecha / Right 601.130.-.- 601.132.-.- Gauche / Izquierda / Left 601.131.-.- 601.133.-.-												
Poste compact exécutf Compacto ejecutivo Executive desks	200 x 120 cm	Droit / Derecha / Right 601.342.-.- Gauche / Izquierda / Left 601.343.-.-												

## FINITIONS | ACABADOS | FINISHES

STRUCTURE / ESTRUCTURA / FRAME | PLATEAU / SOBRE / DESK TOP

T3 Piètements mélamine Lateral melamina Panel legs	075 Blanc Blanco White	054 Gris Gris Grey	055 Hêtre Haya Beech	061 Chêne Moyen Roble Maple	062 Poirier Peral Pear
Argent Plata Silver	116 Wengué Wengue Wengue	694 Acacia Clair Acacia Clara Light Acacia	695 Acacia Foncé Acacia Oscura Dark Acacia	115 Graphite Grafito Graphite	272 Chêne Veiné Castaño Claro Oak
Blanc Blanco White	273 Chêne Grisè Castaño Oscuro Dark Oak				

## MODÈLES | VARIANTES | VERSIONS

T2

MODÈLE / VARIANTES / VERSIONS	DIMENSIONS / MEDIDAS / MEASUREMENTS	RÉFÉRENCE / REFERENCIA / CODE
Bureau individuel Mesa individual Rectangular desks	180 x 80 cm 160 x 80 cm 140 x 80 cm 120 x 80 cm 100 x 80 cm 80 x 80 cm	601.201.-.- 601.202.-.- 601.203.-.- 601.204.-.- 601.205.-.- 601.206.-.-
Poste compact B Compacto B L-shaped desk B	180 x 120 cm 160 x 120 cm	Droit / Derecha / Right 601.420.-.- 601.422.-.- Gauche / Izquierda / Left 601.421.-.- 601.423.-.-
Poste compact exécutf Compacto ejecutivo Executive desks	200 x 120 cm	Droit / Derecha / Right 601.442.-.- Gauche / Izquierda / Left 601.443.-.-









## FINITIONS | ACABADOS | FINISHES

STRUCTURE / ESTRUCTURA / FRAME | PLATEAU / SOBRE / DESK TOP



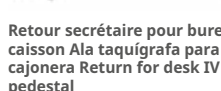

T2 Piètements en métal Lateral metálico T-shape frame	060 Blanc Blanco White	064 Gris Gris Grey	065 Hêtre Haya Beech	066 Chêne Moyen Roble Maple	067 Poirier Peral Pear
Argent Plata Silver RAL 9006	068 Wengué Wengue Wengue	706 Acacia Clair Acacia Clara Light Acacia	707 Acacia Foncé Acacia Oscura Dark Acacia	020 Graphite Grafito Graphite	031 Chêne Veiné Castaño Claro Oak
Blanc Blanco White RAL 9016	032 Chêne Grisè Castaño Oscuro Dark Oak				

# | COMPLÉMENTS | COMPLEMENTOS | COMPLEMENTS

T3 / T2

MODÈLE / VARIANTES / VERSIONS	DIMENSIONS / MEDIDAS / MEASUREMENTS	RÉFÉRENCE / REFERENCIA / CODE	
	100 x 60 cm 80 x 60 cm	601.251.-.- 601.252.-.-	
<b>Retour secrétaire</b> Ala taquígrafa rectangular Return			
	100 x 60 cm 80 x 60 cm	À droite / Derecha / Right 601.260.-.- 601.262.-.-	À gauche / Izquierda / Left 601.261.-.- 601.263.-.-
<b>Retour secrétaire avec forme</b> Ala taquígrafa con forma Return with shape			
	3 Tiroirs / Cajones / Drawers 100 x 60 cm 80 x 60 cm	601.253.-.- 601.254.-.-	
<b>Retour secrétaire avec caisson</b> Ala taquígrafa con cajonera Return with fixed pedestal			
	1 Tiroir / Cajón / Drawer + 1 DS / Archivo / File 100 x 60 cm 80 x 60 cm	601.255.-.- 601.256.-.-	
<b>Retour secrétaire avec forme et caisson</b> Ala taquígrafa con forma y cajonera Shape return with fixed pedestal			
	152 x 51,5 cm	À droite / Derecha / Right 601.280.-.-	À gauche / Izquierda / Left 601.281.-.-
<b>Retour secrétaire pour bureau IV</b> Ala taquígrafa para mesa IV Return for desk IV			
	3 Tiroirs / Cajones / Drawers 152 x 51,5 cm	601.282.-.-	601.283.-.-
<b>Retour secrétaire pour bureau IV avec caisson</b> Ala taquígrafa para mesa IV con cajonera Return for desk IV with fixed pedestal			
	1 Tiroir / Cajón / Drawer + 1 DS / Archivo / File 152 x 51,5 cm	601.284.-.-	601.285.-.-
<b>Retour secrétaire pour bureau IV avec caisson</b> Ala taquígrafa para mesa IV con cajonera Return for desk IV with fixed pedestal			
	80 x 40 cm	601.334.-.-	
<b>Demi-rond</b> Semicircular Semicircular			

# | COMPLÉMENTS | COMPLEMENTOS | COMPLEMENTS

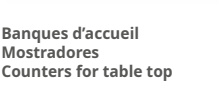
MODÈLE / VARIANTES / VERSIONS	DIMENSIONS / MEDIDAS / MEASUREMENTS	RÉFÉRENCE / REFERENCIA / CODE	
	161 x 40 cm	601.332.-.-	
<b>Demi-rond</b> Semicircular Semicircular			
	50,4 x 43,4 cm	601.333.-.-	
<b>Semi-elliptique</b> Semiéllíptico Semielliptic			
	80 x 80 cm	1.601.030.-.-	
<b>Angle concave 90°</b> Ángulo cóncavo 90° 90° Concave angle			
	180 x 37 cm 160 x 37 cm 140 x 37 cm 120 x 37 cm 100 x 37 cm 80 x 37 cm	1.233.004.-.- 1.233.006.-.- 1.233.008.-.- 1.233.010.-.- 1.233.011.-.- 1.233.012.-.-	
<b>Banques d'accueil</b> Mostradores Counters for table top			
	Angle concave / Ángulo cóncavo / Concave angle 107 x 37 cm	1.233.021.-.-	
<b>FINITIONS ACABADOS FINISHES</b>			
053 Blanc Blanco White	054 Gris Gris Grey	055 Hêtre Haya Beech	061 Chêne Moyen Roble Maple
062 Poirier Peral Pear	063 Wengué Wengue Wengue	103 Acacia Clair Acacia Clara Light Acacia	104 Acacia Foncé Acacia Oscura Dark Acacia
105 Zebrano Zebrano	007 Graphite Grafito Graphite	272 Chêne Veiné Castaño Claro Oak	273 Chêne Gris Castaño Oscuro Dark Oak

# | FINITIONS | ACABADOS | FINISHES

STRUCTURE / ESTRUCTURA / FRAME | PLATEAU / SOBRE / DESK TOP

Piètements en métal Lateral metálico T-shape frame	060 Blanc Blanco White	064 Gris Gris Grey	065 Hêtre Haya Beech	066 Chêne Moyen Roble Maple	067 Poirier Peral Pear
Argent Plata Silver RAL 9006	068 Wengué Wengue Wengue	706 Acacia Clair Acacia Clara Light Acacia	707 Acacia Foncé Acacia Oscura Dark Acacia	020 Graphite Grafito Graphite	031 Chêne Veiné Castaño Claro Oak
Blanc Blanco White RAL 9016	032 Chêne Gris Castaño Oscuro Dark Oak				

# CLOISONNETTES FRONTALES | PLAFONES | FRONT SCREENS

1 NIVEAU / 1 NIVEL / 1 LEVEL

2 NIVEAUX / 2 NIVELES / 2 LEVELS

MODÈLE / VARIANTES / VERSIONS	L.	RÉFÉRENCE / REFERENCIA / CODE	MODÈLE / VARIANTES / VERSIONS	L.	RÉFÉRENCE / REFERENCIA / CODE
-------------------------------	----	-------------------------------	-------------------------------	----	-------------------------------

PINCES / PINZAS / BRACKET	RAL 9006		RAL 9016	
	Indiv. / Individ. / Single			
Vis à vis / Enfrentadas / Face to face				
180 cm	386.008.-..	386.108.-..		
160 cm	386.009.-..	386.109.-..		
140 cm	386.010.-..	386.110.-..		
120 cm	386.011.-..	386.111.-..		
80 cm	386.013.-..	386.113.-..		

Mélamine  
Melamina  
Melamine

FINITIONS ACABADOS FINISHES		007		Graphite Grafito Graphite		051		Argent Plata Silver	
053	Blanc Blanco White	054	Gris Gris Grey	055	Hêtre Haya Beech	061	Chêne Moyen Roble Maple	062	Poirier Peral Pear
103	Acacia Clair Acacia Clara Light Acacia	104	Acacia Foncé Acacia Oscura Dark Acacia	272	Chêne Veiné Castaño Claro Oak	273	Chêne Gris Castaño Oscuro Dark Oak		

PINCES / PINZAS / BRACKET	RAL 9006		RAL 9016	
	Indiv. / Individ. / Single			
Vis à vis / Enfrentadas / Face to face				
180 cm	386.021.-..	386.121.-..		
160 cm	386.022.-..	386.122.-..		
140 cm	386.023.-..	386.123.-..		
120 cm	386.024.-..	386.124.-..		
80 cm	386.026.-..	386.126.-..		

Mélamine  
Melamina  
Melamine

FINITIONS ACABADOS FINISHES		204		Graphite Grafito Graphite		088		Argent Plata Silver	
081	Blanc Blanco White	197	Gris Gris Grey	198	Hêtre Haya Beech	199	Chêne Moyen Roble Maple	200	Poirier Peral Pear
103	Acacia Clair Acacia Clara Light Acacia	104	Acacia Foncé Acacia Oscura Dark Acacia	209	Chêne Veiné Castaño Claro Oak	235	Chêne Gris Castaño Oscuro Dark Oak		

PINCES / PINZAS / BRACKET	RAL 9006		RAL 9016	
	Indiv. / Individ. / Single			
Vis à vis / Enfrentadas / Face to face				
180 cm	386.008.000	386.108.000		
160 cm	386.009.000	386.109.000		
140 cm	386.010.000	386.110.000		
120 cm	386.011.000	386.111.000		
80 cm	386.013.000	386.113.000		

Tissu Tapizado Upholstered

FINITIONS ACABADOS FINISHES  
Cf. page 464  
Ver pagina 464  
See page 464

PINCES / PINZAS / BRACKET	RAL 9006		RAL 9016	
	Indiv. / Individ. / Single			
Vis à vis / Enfrentadas / Face to face				
180 cm	386.021.000	386.121.000		
160 cm	386.022.000	386.122.000		
140 cm	386.023.000	386.123.000		
120 cm	386.024.000	386.124.000		
80 cm	386.026.000	386.126.000		

Tissu Tapizado Upholstered

FINITIONS ACABADOS FINISHES  
Cf. page 464  
Ver pagina 464  
See page 464

PINCES / PINZAS / BRACKET	RAL 9006		RAL 9016	
	Indiv. / Individ. / Single			
Vis à vis / Enfrentadas / Face to face				
180 cm	386.008.-..	386.108.-..		
160 cm	386.009.-..	386.109.-..		
140 cm	386.010.-..	386.110.-..		
120 cm	386.011.-..	386.111.-..		
80 cm	386.013.-..	386.113.-..		

Méthacrylate Metacrilato Methacrylate

FINITIONS ACABADOS FINISHES  
411 Transparente Transparent Clear  
412 Blanc opaque Translúcido Transparent

PINCES / PINZAS / BRACKET	RAL 9006		RAL 9016	
	Indiv. / Individ. / Single			
Vis à vis / Enfrentadas / Face to face				
180 cm	386.021.-..	386.121.-..		
160 cm	386.022.-..	386.122.-..		
140 cm	386.023.-..	386.123.-..		
120 cm	386.024.-..	386.124.-..		
80 cm	386.026.-..	386.126.-..		

Avec méthacrylate et tissu  
Con metacrilato y tapizado  
With methacrylate and upholstered

FINITIONS ACABADOS FINISHES  
406 Transparente Transparent Clear  
427 Blanc opaque Translúcido Transparent  
Cf. page 464  
Ver pagina 464  
See page 464

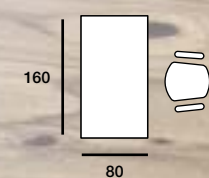

# ROCK 3

La série ROCK 3 se caractérise par son pied panneau mélaminé. Elle vous permet de meubler votre bureau au meilleur prix possible, avec une grande gamme de finitions.

ROCK 3 se caracteriza por un lateral tipo panel. Permite amueblar las oficinas al mejor precio, con gran variedad de acabados.

ROCK 3 melamine panel legs range is an affordable, high quality and stylish furniture, enabling customers to furnish their office space within a specific budget,

## PLATEAU / SOBRE / DESK TOP

Mélamine / Melamina / Melamine: 25 mm

Chant en ABS / Canto ABS / ABS edges

## STRUCTURE / ESTRUCTURA / FRAME

Mélamine / Melamina / Melamine

25

## HAUTEUR / ALTURA / HEIGHT

73 cm

## OPTION / OPCIÓN / OPTION

Cloisonnettes / Plafones / Screens



BUREAU INDIVIDUEL  
AVEC RETOUR

MESA INDIVIDUAL  
CON ALA

INDIVIDUAL DESK  
WITH RETURN

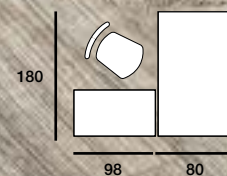



Entretroise en PVC.  
Distanciador de plástico.  
Plastic top spacers.

POSTES  
COMPACTS  
EN VIS À VIS

PUESTOS  
COMPACTOS  
ENFRENTADOS

L-SHAPE  
FACE TO FACE  
DESKS

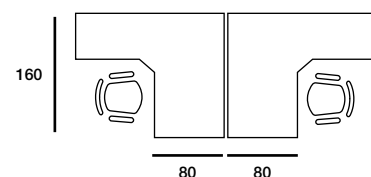

POSTE  
COMPACT  
ÉXÉCUTIF

PUESTO  
COMPACTO  
EJECUTIVO

EXECUTIVE  
DESK



Design simple et élégant.  
Un diseño simple y elegante.  
A simple and smart design.

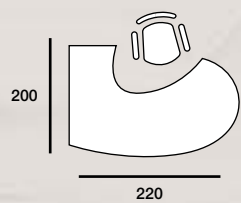

## MODÈLES | VARIANTES | VERSIONS

MODÈLE / VARIANTES / VERSIONS	DIMENSIONS / MEDIDAS / MEASUREMENTS	RÉFÉRENCE / REFERENCIA / CODE
	180 x 80 cm 160 x 80 cm 140 x 80 cm 120 x 80 cm 80 x 80 cm	431.101.-.- 431.102.-.- 431.103.-.- 431.104.-.- 431.105.-.-
Bureau rectangulaire Mesa individual Rectangular desks		

## FINITIONS | ACABADOS | FINISHES

053	Blanc Blanco White	054	Gris Gris Grey	055	Hêtre Haya Beech	061	Chêne Moyen Roble Maple	062	Poirier Peral Pear
116	Wengué Wengue Wengue	103	Acacia Clair Acacia Clara Light Acacia	104	Acacia Foncé Acacia Oscura Dark Acacia	007	Graphite Grafito Graphite	272	Chêne Veiné Castaño Claro Oak
273	Chêne Grisé Castaño Oscuro Dark Oak								

## MODÈLES | VARIANTES | VERSIONS

MODÈLE / VARIANTES / VERSIONS	DIMENSIONS / MEDIDAS / MEASUREMENTS	RÉFÉRENCE / REFERENCIA / CODE	
	180 x 120 cm 160 x 120 cm	Droit / Derecha / Right 431.146.-.- 431.160.-.-	Gauche / Izquierda / Left 431.147.-.- 431.161.-.-
Poste compact VII Compacto VII L-shaped desks VII			

	220 x 138 cm 200 x 138 cm	Droit / Derecha / Right 431.126.-.- 431.128.-.-	Gauche / Izquierda / Left 431.127.-.- 431.129.-.-
Poste compact exécutif Compacto ejecutivo Executive desks			

## FINITIONS | ACABADOS | FINISHES

060	Blanc Blanco White	064	Gris Gris Grey	065	Hêtre Haya Beech	066	Chêne Moyen Roble Maple	067	Poirier Peral Pear
068	Wengué Wengue Wengue	706	Acacia Clair Acacia Clara Light Acacia	707	Acacia Foncé Acacia Oscura Dark Acacia	020	Graphite Grafito Graphite	031	Chêne Veiné Castaño Claro Oak
032	Chêne Grisé Castaño Oscuro Dark Oak								

## COMPLÉMENTS | COMPLEMENTOS | COMPLEMENTS

MODÈLE / VARIANTES / VERSIONS	DIMENSIONS / MEDIDAS / MEASUREMENTS	RÉFÉRENCE / REFERENCIA / CODE
	110 x 60 cm	431.114.-.-
Bureau secrétaire Mesa taquígrafa Shorthand desk		

	98 x 60 cm	431.115.-.-
Retour secrétaire Ala taquígrafa Return		

	123 X 78,3 cm	431.017.-.-
Angle concave 90° Ángulo cóncavo 90° 90° concave angle		

### FINITIONS ACABADOS FINISHES

053	Blanc Blanco White	054	Gris Gris Grey	055	Hêtre Haya Beech
061	Chêne Moyen Roble Maple	062	Poirier Peral Pear	116	Wengué Wengue Wengue
103	Acacia Clair Acacia Clara Light Acacia	104	Acacia Foncé Acacia Oscura Dark Acacia	007	Graphite Grafito Graphite
272	Chêne Veiné Castaño Claro Oak	273	Chêne Grisé Castaño Oscuro Dark Oak		

## FINITIONS | ACABADOS | FINISHES

053	Blanc Blanco White	054	Gris Gris Grey	055	Hêtre Haya Beech	061	Chêne Moyen Roble Maple	062	Poirier Peral Pear
063	Wengué Wengue Wengue	103	Acacia Clair Acacia Clara Light Acacia	104	Acacia Foncé Acacia Oscura Dark Acacia	007	Graphite Grafito Graphite	272	Chêne Veiné Castaño Claro Oak
273	Chêne Grisé Castaño Oscuro Dark Oak								

# | COMPLÉMENTS | COMPLEMENTOS | COMPLEMENTS

MODÈLE / VARIANTES / VERSIONS	DIMENSIONS / MEDIDAS / MEASUREMENTS	RÉFÉRENCE / REFERENCIA / CODE
-------------------------------	-------------------------------------	-------------------------------



160 x 70 cm

431.119.---

Demi-rond  
Semicircular  
Semircircular



160 x 40 cm

431.122.---

Semi-elliptique  
Semielliptico  
Semielliptic

## | FINITIONS | ACABADOS | FINISHES

060	Blanc Blanco White	064	Gris Gris Grey	065	Hêtre Haya Beech	066	Chêne Moyen Roble Maple	067	Poirier Peral Pear
068	Wengué Wengue Wengue	706	Acacia Clair Acacia Clara Light Acacia	707	Acacia Foncé Acacia Oscura Dark Acacia	020	Graphite Grafito Graphite	031	Chêne Veiné Castaño Claro Oak
032	Chêne Grisé Castaño Oscuro Dark Oak								

## | CLOISONNETTES FRONTALES | PLAFONES | FRONT SCREENS

1 NIVEAU / 1 NIVEL / 1 LEVEL

MODÈLE / VARIANTES / VERSIONS	L	RÉFÉRENCE / REFERENCIA / CODE
-------------------------------	---	-------------------------------



Indiv. / Indiv. / Single

180 cm  
160 cm  
140 cm  
120 cm  
80 cm

406.004.---  
406.006.---  
406.008.---  
406.010.---  
406.014.---

Mélamine  
Melamina  
Melamine

FINITIONS  
ACABADOS  
FINISHES

051	Argent Plata Silver	053	Blanc Blanco White	054	Gris Gris Grey	055	Hêtre Haya Beech	061	Chêne Moyen Roble Maple
062	Poirier Peral Pear	063	Wengué Wengue Wengue	103	Acacia Clair Acacia Clara Light Acacia	104	Acacia Foncé Acacia Oscura Dark Acacia	007	Graphite Grafito Graphite
272	Chêne Veiné Castaño Claro Oak	273	Chêne Grisé Castaño Oscuro Dark Oak						





DIRECTION  
DIRECCIÓN  
EXECUTIVE DESKS



**146** | TAK



**156** | OPEN

# TAK

C'est une série de direction aux lignes droites et élégantes qui s'éloigne de tout ce qui est prétentieux.

Es una serie direccional que se armoniza para crear un sitio de trabajo funcional y práctico, de líneas rectas y puras en todo su conjunto.

TAK is a solid, straight lined and at the same time elegant looking executive range.

## PLATEAU / SOBRE / DESK TOP

Mélamine / Melamina / Melamine: 40 mm

Chant en ABS / Canto ABS / ABS edges

## STRUCTURE / ESTRUCTURA / FRAME

Mélamine / Melamina / Melamine:

40

## FINITION STRUCTURE / ACABADO ESTRUCTURA / FRAME FINISH

Mélamine ou bois vernis  
Melamina o madera barnizada  
Melamine or wood veneer

## HAUTEUR / ALTURA / HEIGHT

73 cm

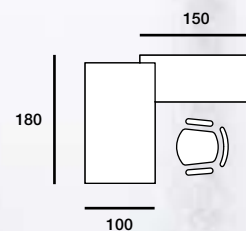

BUREAU DE  
DIRECTION  
AVEC CRÉDENCE

MESA DE  
DIRECCIÓN  
CON CREDENCIA

EXECUTIVE  
DESK WITH  
SIDE CREDENZA



BUREAU DE  
DIRECTION  
AVEC RETOUR

MESA DE  
DIRECCIÓN  
CON ALA

EXECUTIVE  
DESK WITH  
RETURN



Entretoises et patins, finition chromée.  
Distanciadores acabados en cromado.  
Chrome top spacers.

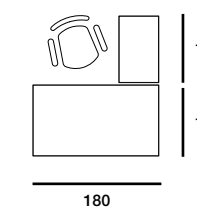



BUREAU DE  
DIRECTION

MESA DE  
DIRECCIÓN

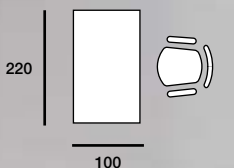
EXECUTIVE  
DESK



## MODÈLES | VARIANTES | VERSIONS

MODÈLE / VARIANTES / VERSIONS	DIMENSIONS / MEDIDAS / MEASUREMENTS	RÉFÉRENCE / REFERENCIA / CODE		
 <p><b>Bureau de direction</b> Mesa de dirección Executive desk</p>	220 x 100 cm 200 x 100 cm 180 x 100 cm 160 x 100 cm	Mélamine Melamina Melamine	Noyer Américain Nogal Americano American Walnut	
		561.100.-.-	561.400.365	
		561.101.-.-	561.401.365	
		561.102.-.-	561.402.365	
	180 x 80 cm 160 x 80 cm 140 x 80 cm	561.103.-.-	561.403.365	
		561.105.-.-	561.405.365	
		561.106.-.-	561.406.365	
		561.107.-.-	561.407.365	
 <p><b>Bureau de direction pour crédence fixe</b> Mesa de dirección con credencia Executive desk with side credenza</p>	À droite / Derecha / Right	220 x 100 cm 200 x 100 cm 180 x 100 cm 160 x 100 cm	Mélamine Melamina Melamine	Noyer Américain Nogal Americano American Walnut
			561.150.-.-	561.450.365
			561.152.-.-	561.452.365
			561.154.-.-	561.454.365
			561.156.-.-	561.456.365
	À gauche / Izquierda / Left	220 x 100 cm 200 x 100 cm 180 x 100 cm 160 x 100 cm	561.151.-.-	561.451.365
			561.153.-.-	561.453.365
			561.155.-.-	561.455.365
			561.157.-.-	561.457.365

## FINITIONS | ACABADOS | FINISHES

Monochrome Monocolor Single-colour	053	Blanc Blanco White	103	Acacia Clair Acacia Clara Light Acacia	104	Acacia Foncé Acacia Oscura Dark Acacia	272	Chêne Veiné Castaño Claro Oak
	273	Chêne Grisé Castaño Oscuro Dark Oak		Noyer Américain Nogal Americano American Walnut				

## COMPLÉMENTS | COMPLEMENTOS | COMPLEMENTS

MODÈLE / VARIANTES / VERSIONS	TYPE / TIPO / TYPE	DIMENSIONS / MEDIDAS / MEASUREMENTS	RÉFÉRENCE / REFERENCIA / CODE		
 <p><b>Retour secrétaire</b> Ala taquígrafa Return</p>	Pour bureaux P.100 / para mesas P.100 / for desks D.100	100 x 60 cm 80 x 60 cm	Mélamine Melamina Melamine	Noyer Américain Nogal Americano American Walnut	
			561.110.-.-	561.410.365	
	Pour bureaux P.80 / para mesas P.80 / for desks D.80	100 x 60 cm 80 x 60 cm	561.111.-.-	561.411.365	
			561.112.-.-	561.412.365	
			561.113.-.-	561.413.365	
 <p><b>Crédence à roulettes</b> Credencia con ruedas Side credenza with wheels</p>	À droite / Derecha / Right	Prof./ Depth. 57 cm L. 115 H. 58,5 cm L. 87 H. 58,5 cm L. 72 H. 58,5 cm	3 Tiroirs / Cajones / Drawers	342.410.-.-	342.810.365
				342.414.-.-	342.814.365
				342.418.-.-	342.818.365
	À gauche / Izquierda / Left	L. 115 H. 58,5 cm L. 87 H. 58,5 cm L. 72 H. 58,5 cm	1 Tiroir / Cajón / Drawer + 1 DS / Archivo / File	342.412.-.-	342.812.365
				342.416.-.-	342.816.365
				342.420.-.-	342.820.365
		Prof./ Depth. 57 cm			
	À gauche / Izquierda / Left	L. 115 H. 58,5 cm L. 87 H. 58,5 cm L. 72 H. 58,5 cm	3 Tiroirs / Cajones / Drawers	342.411.-.-	342.811.365
				342.415.-.-	342.815.365
				342.419.-.-	342.819.365
		L. 115 H. 58,5 cm L. 87 H. 58,5 cm L. 72 H. 58,5 cm	1 Tiroir / Cajón / Drawer + 1 DS / Archivo / File	342.413.-.-	342.813.365
				342.417.-.-	342.817.365
			342.421.-.-	342.821.365	

## COMPLÉMENTS | COMPLEMENTOS | COMPLEMENTS

MODÈLE / VARIANTES / VERSIONS	TYPE / TIPO / TYPE	DIMENSIONS / MEDIDAS / MEASUREMENTS	RÉFÉRENCE / REFERENCIA / CODE		
 <p><b>Crédence fixe avec portes coulissantes</b> Credencia con puertas correderas Side credenza with sliding doors</p>		Prof./ Depth. 54,2 cm	Mélamine Melamina Melamine	Noyer Américain Nogal Americano American Walnut	
	À droite / Derecha / Right	L. 200 H. 56,2 cm L. 150 H. 56,2 cm	1 porte coulissante / 1 puerta corredera / Sliding door	562.101.-.-	562.401.365
				562.105.-.-	562.405.365
	À gauche / Izquierda / Left	L. 200 H. 56,2 cm L. 150 H. 56,2 cm	2 portes coulissantes / 2 puertas correderas / Sliding doors	562.102.-.-	562.402.365
				562.106.-.-	562.406.365
				562.103.-.-	562.403.365
	À droite / Derecha / Right	L. 200 H. 56,2 cm L. 150 H. 56,2 cm	562.107.-.-	562.407.365	
	À gauche / Izquierda / Left	L. 200 H. 56,2 cm L. 150 H. 56,2 cm	562.104.-.-	562.404.365	
			562.108.-.-	562.408.365	
 <p><b>Caisson à roulettes</b> Cajonera con ruedas Mobile pedestal</p>	3 Tiroirs / Cajones / Drawers	57 x 44 H. 55,5 cm	Mélamine Melamina Melamine	Noyer Américain Nogal Americano American Walnut	
			342.400.-.-	342.800.365	
	1 Tiroir / Cajón / Drawer + 1 DS / Archivo / File	57 x 44 H. 55,5 cm	342.401.-.-	342.801.365	

## FINITIONS | ACABADOS | FINISHES

Monochrome Monocolor Single-colour	053	Blanc Blanco White	103	Acacia Clair Acacia Clara Light Acacia	104	Acacia Foncé Acacia Oscura Dark Acacia	272	Chêne Veiné Castaño Claro Oak
	273	Chêne Grisé Castaño Oscuro Dark Oak		Noyer Américain Nogal Americano American Walnut				

## COMPLÉMENTS | COMPLEMENTOS | COMPLEMENTS

MODÈLE / VARIANTES / VERSIONS	TYPE / TIPO / TYPE	DIMENSIONS / MEDIDAS / MEASUREMENTS	RÉFÉRENCE / REFERENCIA / CODE		
 <p><b>Goulotte</b> Bandeja electrificación Cable tray</p>	Pour bureaux / para mesas / for desks:	220 cm 200 cm 180 cm 160 cm	Indiv. / Indiv. / Single		
			1.566.001.111	1.566.001.108	1.566.001.107
			1.566.002.111	1.566.002.108	1.566.002.107
			1.566.003.111	1.566.003.108	1.566.003.107
			1.566.004.111	1.566.004.108	1.566.004.107

## FINITIONS | ACABADOS | FINISHES

Argent Plata Silver	Blanc Blanco White	Graphite Grafito Graphite
RAL 9006	RAL 9016	RAL 7022

# | COMPLÉMENTS | COMPLEMENTOS | COMPLEMENTS

MODÈLE / VARIANTES / VERSIONS	RÉFÉRENCE / REFERENCIA / CODE
 <p>Sous-main Vade Leather pad</p>	<p>561.001.000</p>  <p>Cf. page 464 - Série 7 Ver pagina 464 - Serie 7 See page 464 - Serie 7</p>

# | MODÈLES | VARIANTES | VERSIONS

## ARMOIRES / ARMARIOS / CABINETS

ÉTAGÈRES INCLUSES / ESTANTES INCLUIDOS / INCLUDED SHELVES

MODÈLE / VARIANTES / VERSIONS	TYPE / TIPO / TYPE	DIMENSIONS / MEDIDAS / MEASUREMENTS	RÉFÉRENCE / REFERENCIA / CODE
 <p>Armoire ouverte avec étagères Armario con estantes Cabinet shelves</p>	Prof./ Depth. 42 cm	L. 100 H. 201,4 cm L. 100 H. 147 cm L. 100 H. 76,6 cm	Mélamine Melamina Melamina  Noyer Américain Nogal Americano American Walnut  345.504.-... 345.704.365 345.502.-... 345.702.365 345.506.-... 345.706.365

 <p>Armoire portes en mélamine Armario con puertas de melamina Cabinet with doors</p>	Prof./ Depth. 42 cm	L. 100 H. 201,4 cm L. 100 H. 147 cm L. 100 H. 76,6 cm	345.505.-... 345.705.365 345.503.-... 345.703.365 345.507.-... 345.707.365
--	---------------------	---	--

 <p>Armoire avec DS Armario con archivos Files cabinet</p>	Prof./ Depth. 42 cm	L. 100 H. 76,6 cm	345.512.-... 345.712.365
---	---------------------	-------------------	--------------------------

# | FINITIONS | ACABADOS | FINISHES

Monochrome Monocolor Single-colour	053 Blanc Blanco White	103 Acacia Clair Acacia Clara Light Acacia	104 Acacia Foncé Acacia Oscura Dark Acacia	272 Chêne Veiné Castaño Claro Oak
	273 Chêne Grisé Castaño Oscuro Dark Oak			Noyer Américain Nogal Americano American Walnut

# | MODÈLES | VARIANTES | VERSIONS

## ARMOIRES PORTES EN VERRE / ARMARIOS PUERTAS VIDRIO / GLASS DOORS CABINETS

ÉTAGÈRES INCLUSES / ESTANTES INCLUIDOS / INCLUDED SHELVES

MODÈLE / VARIANTES / VERSIONS	TYPE / TIPO / TYPE	DIMENSIONS / MEDIDAS / MEASUREMENTS	RÉFÉRENCE / REFERENCIA / CODE
 <p>Armoire portes en verre Armario con puertas de vidrio Cabinet with glass doors</p>	Prof./ Depth. 42 cm	L.100 H.201,4 cm L.100 H.147 cm L.100 H.76,6 cm	Mélamine Melamina Melamina  Noyer Américain Nogal Americano American Walnut  345.505.-... 345.705.-... 345.503.-... 345.703.-... 345.507.-... 345.707.-...

 <p>Armoire portes en verre - portes en mélamine Puertas vidrio - puertas Upper glass doors with low doors</p>	Prof./ Depth. 42 cm	L.100 H.201,4 cm L.100 H.147 cm	345.508.-... 345.708.-... 345.509.-... 345.709.-...
---	---------------------	------------------------------------	--

 <p>Armoire portes en verre - DS Puertas vidrio - archivo Upper glass doors with low files</p>	Prof./ Depth. 42 cm	L.100 H.201,4 cm L.100 H.147 cm	345.510.-... 345.710.-... 345.511.-... 345.711.-...
---	---------------------	------------------------------------	--

# | FINITIONS | ACABADOS | FINISHES

## VERRE / VIDRIO / GLASS | STRUCTURE / ESTRUCTURA / FRAME

Blanc Blanco White	436 Blanc Blanco White	439 Acacia Clair Acacia Clara Light Acacia	442 Acacia Foncé Acacia Oscura Dark Acacia	886 Chêne Veiné Castaño Claro Oak	497 Noyer Américain Nogal Americano American Walnut
	889 Chêne Grisé Castaño Oscuro Dark Oak				
Noir Negro Black	437 Blanc Blanco White	440 Acacia Clair Acacia Clara Light Acacia	443 Acacia Foncé Acacia Oscura Dark Acacia	887 Chêne Veiné Castaño Claro Oak	498 Noyer Américain Nogal Americano American Walnut
	890 Chêne Grisé Castaño Oscuro Dark Oak				

Bois vernis  
Madera Barnizada  
Wood veneer

# open

Les besoins actuels de nos centres de travail ont évolué techniquement afin de satisfaire et de s'adapter à notre époque.

Las necesidades actuales en los centros de trabajo han evolucionado técnicamente para satisfacer y adaptarse a estos tiempos.

Current needs at work places have technically developed in order to satisfy us and to adjust to our present time.

## PLATEAU / SOBRE / DESK TOP

Stratifiés / Estratificado / Stratified: 40 mm

## STRUCTURE / ESTRUCTURA / FRAME

Aluminium anodisé:  
Aluminio anodizado:  
Anodised aluminium:

110 x 30 mm



## FINITION STRUCTURE / ACABADO ESTRUCTURA / FRAME FINISH

Peinture époxy  
Pintura epoxi  
Epoxy paint

Bain de chrome  
Baño cromado  
Chrome

## HAUTEUR / ALTURA / HEIGHT

73 cm

## OPTION / OPCIÓN / OPTION

Voile de fond / Faldón / Modesty panel

BUREAU  
DIRECTION

MESA DE  
DIRECCIÓN

EXECUTIVE  
DESK





Sous-mains en cuir.  
Vade de piel.  
Leather pad.



BUREAU  
INDIVIDUEL  
AVEC CRÉDENCE

MESA  
INDIVIDUAL  
CON CREDENCIA

EXECUTIVE  
DESK WITH  
SIDE CREDENZA

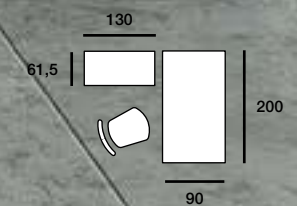



BUREAU DE  
DIRECTION  
AVEC RETOUR

MESA DE  
DIRECCIÓN  
CON ALA

EXECUTIVE  
DESK WITH  
RETURN



Vous pouvez compléter la composition avec un caisson à roulettes non visibles.  
Se puede completar el conjunto con una cajonera con ruedas ocultas.  
Executive mobile pedestal with hidden wheels is also available.

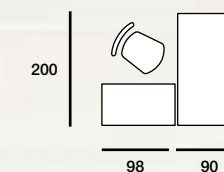







## MODÈLES | VARIANTES | VERSIONS

MODÈLE / VARIANTES / VERSIONS	DIMENSIONS / MEDIDAS / MEASUREMENTS	RÉFÉRENCE / REFERENCIA / CODE
	220 x 90 cm 200 x 90 cm 180 x 90 cm	341.100.-.- 341.101.-.- 341.102.-.-

Bureau de direction  
Mesa de dirección  
Executive desk

## FINITIONS | ACABADOS | FINISHES

STRUCTURE / ESTRUCTURA / FRAME | PLATEAU / SOBRE / DESK TOP

 Blanc Blanco White RAL 9016	144  Blanc Blanco White	145  Acacia Clair Acacia Clara Light Acacia	146  Acacia Foncé Acacia Oscura Dark Acacia
 Chromée Cromado Chrome	148  Blanc Blanco White	149  Acacia Clair Acacia Clara Light Acacia	150  Acacia Foncé Acacia Oscura Dark Acacia

## COMPLÉMENTS | COMPLEMENTOS | COMPLEMENTS

MODÈLE / VARIANTES / VERSIONS	TYPE / TIPO / TYPE	DIMENSIONS / MEDIDAS / MEASUREMENTS	RÉFÉRENCE / REFERENCIA / CODE
	Prof. / Depth. 57 cm	L.158 H.61,5 cm L.130 H.61,5 cm L.115 H.61,5 cm	342.510.-.- 342.511.-.- 342.512.-.-



Crédence à roulettes et top en verre  
Credencia con ruedas y sobre de vidrio  
Side credenza with wheels and glass top

## FINITIONS | ACABADOS | FINISHES

VERRE / VIDRIO / GLASS | STRUCTURE / ESTRUCTURA / FRAME

 Blanc Blanco White	436  Blanc Blanco White	439  Acacia Clair Acacia Clara Light Acacia	442  Acacia Foncé Acacia Oscura Dark Acacia
 Noir Negro Black	437  Blanc Blanco White	440  Acacia Clair Acacia Clara Light Acacia	443  Acacia Foncé Acacia Oscura Dark Acacia

## COMPLÉMENTS | COMPLEMENTOS | COMPLEMENTS

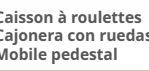
MODÈLE / VARIANTES / VERSIONS	TYPE / TIPO / TYPE	DIMENSIONS / MEDIDAS / MEASUREMENTS	RÉFÉRENCE / REFERENCIA / CODE
	Prof. / Depth. 57 cm	L.115 H.61,5 cm L.87 H.61,5 cm L.72 H.61,5 cm	342.513.-.- 342.514.-.- 342.515.-.-
	3 Tiroirs / Cajones / Drawers	57 x 44 H.55,5 cm	Gamme basique Gama básica Basic range 342.500.-.-
	1 Tiroir / Cajón / Drawer + 1 DS / Archivo / File	57 x 44 H.55,5 cm	342.501.-.-

Crédence à roulettes  
Credencia con ruedas  
Side credenza with wheels

Caisson à roulettes  
Cajonera con ruedas  
Mobile pedestal



Sous-main en cuir  
Vade  
Leather pad













341.800.000



Cf. page 464 - Série 7  
Ver pagina 464 - Serie 7  
See page 464 - Serie 7

## FINITIONS | ACABADOS | FINISHES

FAÇADES OU PORTES / DELANTERAS O PUERTAS / DOORS OR FRONTS | STRUCTURE / ESTRUCTURA / FRAME

 Blanc Blanco White	053  Blanc Blanco White	171  Acacia Clair Acacia Clara Light Acacia	174  Acacia Foncé Acacia Oscura Dark Acacia
 Acacia Clair Acacia Clara Light Acacia	168  Blanc Blanco White	103  Acacia Clair Acacia Clara Light Acacia	175  Acacia Foncé Acacia Oscura Dark Acacia
 Acacia Foncé Acacia Oscura Dark Acacia	169  Blanc Blanco White	172  Acacia Clair Acacia Clara Light Acacia	104  Acacia Foncé Acacia Oscura Dark Acacia



## MODÈLES | VARIANTES | VERSIONS

ARMOIRES / ARMARIOS / CABINETS  
ÉTAGÈRES INCLUSES / ESTANTES INCLUIDOS / INCLUDED SHELVES

MODÈLE / VARIANTES / VERSIONS	TYPE / TIPO / TYPE	DIMENSIONS / MEDIDAS / MEASUREMENTS	RÉFÉRENCE / REFERENCIA / CODE
	Prof./ Depth. 42 cm	L.100 H.201,4 cm L.100 H.147 cm L.100 H.76,6 cm	345.504.-.- 345.502.-.- 345.506.-.-
<b>Armoire ouverte avec étagères</b> Armario con estantes Cabinet shelves			
	Prof./ Depth. 42 cm	L.100 H.201,4 cm L.100 H.147 cm L.100 H.76,6 cm	345.505.-.- 345.503.-.- 345.507.-.-
<b>Armoire portes en mélamine</b> Armario con puertas de melamina Cabinet with doors			
	Prof./ Depth. 42 cm	L.100 H.76,6 cm	345.512.-.-
<b>Armoire avec DS</b> Armario con archivos Files cabinet			

## FINITIONS | ACABADOS | FINISHES

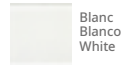
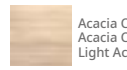
PORTES / PUERTAS / DOORS | STRUCTURE / ESTRUCTURA / FRAME

	053 Blanc Blanco White	171 Acacia Clair Acacia Clara Light Acacia	174 Acacia Foncé Acacia Oscura Dark Acacia
	168 Blanc Blanco White	103 Acacia Clair Acacia Clara Light Acacia	175 Acacia Foncé Acacia Oscura Dark Acacia
	169 Blanc Blanco White	172 Acacia Clair Acacia Clara Light Acacia	104 Acacia Foncé Acacia Oscura Dark Acacia

## MODÈLES | VARIANTES | VERSIONS

ARMOIRES PORTES EN VERRE / ARMARIOS PUERTAS VIDRIO / GLASS DOORS CABINETS  
ÉTAGÈRES INCLUSES / ESTANTES INCLUIDOS / INCLUDED SHELVES

MODÈLE / VARIANTES / VERSIONS	TYPE / TIPO / TYPE	DIMENSIONS / MEDIDAS / MEASUREMENTS	RÉFÉRENCE / REFERENCIA / CODE
	Prof./ Depth. 42 cm	L.100 H.198 cm L.100 H.160 cm L.100 H.73 cm	345.505.-.- 345.503.-.- 345.507.-.-
<b>Armoire portes en verre</b> Armario con puertas de vidrio Cabinet with glass doors			
	Prof./ Depth. 42 cm	L.100 H.198 cm L.100 H.160 cm	345.508.-.- 345.509.-.-
<b>Armoire portes en verre - portes en mélamine</b> Puertas vidrio - puertas Upper glass doors with low doors			
	Prof./ Depth. 42 cm	L.100 H.198 cm L.100 H.160 cm	345.510.-.- 345.511.-.-
<b>Armoire portes en verre - DS</b> Puertas vidrio - archivo Upper glass doors with low files			

## FINITIONS | ACABADOS | FINISHES

VERRE / VIDRIO / GLASS | STRUCTURE / ESTRUCTURA / FRAME

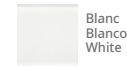
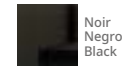
	436 Blanc Blanco White	439 Acacia Clair Acacia Clara Light Acacia	442 Acacia Foncé Acacia Oscura Dark Acacia
	437 Blanc Blanco White	440 Acacia Clair Acacia Clara Light Acacia	443 Acacia Foncé Acacia Oscura Dark Acacia

TABLES HAUTES  
MESAS ALTAS  
HIGH TABLES



168 | BORN



172 | NIL



176 | STAR



180 | TEMPO



184 | MAX 1



188 | MAX 2



192 | TAK



196 | ROCK 3



200 | ROL 1



204 | ROL 2

# BORN

Un bureau au style nordique est possible avec la série BORN. Un design pratique et chaleureux qui répond à toutes les exigences pour créer des espaces calmes, ordonnés, propres et fonctionnels.

Una oficina con estilo nórdico es posible con la serie BORN. Un diseño práctico y cálido que reúne todos los requisitos para crear espacios tranquilos, ordenados, limpios y funcionales.

An office with Nordic style is possible with the BORN series. A practical and warm design due to the wooden legs and therefore able to create serene, neat, and useful spaces.

## PLATEAU / SOBRE / DESK TOP

Mélamine / Melamina / Melamine: 25 mm  
Stratifié / Estratificado / Stratified: 25 mm

Chant en ABS / Canto ABS / ABS edges

## STRUCTURE / ESTRUCTURA / FRAME

Bois: 60 x 60 mm - 60 x 30 mm  
Madera: 60 x 60 mm - 60 x 30 mm  
Wood: 60 x 60 mm - 60 x 30 mm



## FINITION STRUCTURE / ACABADO ESTRUCTURA / FRAME FINISH

Bois ou peinture époxy  
Madera o pintura epoxi  
Wood or epoxy paint

## HAUTEUR / ALTURA / HEIGHT

105 cm

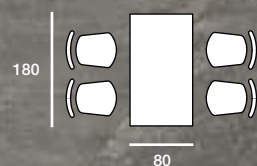















## MODÈLES | VARIANTES | VERSIONS

MODÈLE / VARIANTES / VERSIONS	TYPE / TIPO / TYPE	DIMENSIONS / MEDIDAS / MEASUREMENTS		RÉFÉRENCE / REFERENCIA / CODE		
 <p>Table haute Mesa alta High table</p>	Coins droits / Cantos rectos / Square edges	H 105 cm	180 x 80 cm 160 x 80 cm 120 x 80 cm	639.102.-.- 639.103.-.- 639.105.-.-	639.202.-.- 639.203.-.- 639.205.-.-	639.302.-.- 639.303.-.- 639.305.-.-
	Coins arrondis / Cantos redondeados / Round edges	H 105 cm	180 x 80 cm 160 x 80 cm 120 x 80 cm	639.152.-.- 639.153.-.- 639.155.-.-	639.252.-.- 639.253.-.- 639.255.-.-	639.352.-.- 639.353.-.- 639.355.-.-

## FINITIONS | ACABADOS | FINISHES

RENFORT + PIÉTEMENTS / ARMAZÓN + PATAS  
/ REINFORCEMENT + FRAME

PLATEAU / SOBRE / DESK TOP

 Argent + Hêtre Plata + Haya Silver + Beech	 053 Blanc Blanco White	 054 Gris Gris Grey	 055 Hêtre Haya Beech	 061 Chêne Moyen Roble Maple
 Blanc + Hêtre Blanco + Haya White + Beech	 062 Poirier Peral Pear	 116 Wengué Wengue Wengue	 103 Acacia Clair Acacia Clara Light Acacia	 104 Acacia Foncé Acacia Oscura Dark Acacia
 Graphite + Hêtre Grafito + Haya Graphite + Beech	 007 Graphite Grafito Graphite	 272 Chêne Veiné Castaño Claro Oak	 273 Chêne Grisé Castaño Oscuro Dark Oak	



# NIL

Nil est une série de tables hautes harmonieuses et naturelles, au style chaleureux. Elle se caractérise par les bords arrondis du plateau et les pieds en bois hêtre massif.

Nil es una serie armónica y natural, de mesas altas, con estilo hogareño. Su principal característica reside en los cantos redondeados del sobre y en sus patas de madera de haya maciza.

Nil is a harmonious and pure high table with homely style thanks to its solid beech wood legs. As well it avoids the risk of a painful bump because of the rounded corners of its top.

## PLATEAUX / SOBRES / DESK TOP

Mélamine / Melamina / Melamine: 25 mm  
Stratifié / Estratificado / Stratified: 25 mm

Chant en ABS / Canto ABS / ABS edges

## STRUCTURE / ESTRUCTURA / FRAME

Bois: Ø73 mm - Ø38 mm  
Madera: Ø73 mm - Ø38 mm  
Wood: Ø73-38



## FINITION STRUCTURE / ACABADO ESTRUCTURA / FRAME FINISH

Bois et peinture époxy  
Madera y pintura epoxi  
Wood and epoxy paint

## HAUTEUR / ALTURA / HEIGHT

105 cm

Avec ou sans repose-pieds / Con o sin reposapiés / With or without footrest

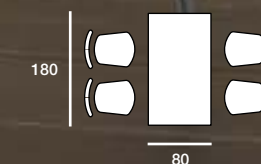

# MODÈLES | VARIANTES | VERSIONS



MODÈLE / VARIANTES / VERSIONS	TYPE / TIPO / TYPE	DIMENSIONS / MEDIDAS / MEASUREMENTS		RÉFÉRENCE / REFERENCIA / CODE	
	Avec repose-pieds Con reposapiés With footrest	H 105 cm	180 x 80 cm	479.122.---	479.322.---
			160 x 80 cm	479.123.---	479.323.---
	Sans repose-pieds Sin reposapiés Without footrest	H 105 cm	180 x 80 cm	479.132.---	479.332.---
			160 x 80 cm	479.133.---	479.333.---
			120 x 80 cm	479.125.---	479.325.---
			120 x 80 cm	479.135.---	479.335.---

Table haute  
Mesa alta  
High table

# FINITIONS | ACABADOS | FINISHES

RENFORT + PIÉTEMENTS / REFUERZO + PATAS  
/ REINFORCEMENT + FRAME

PLATEAU / SOBRE / DESK TOP

	053	Blanc Blanco White	054	Gris Gris Grey	055	Hêtre Haya Beech	061	Chêne Moyen Roble Maple
	062	Poirier Peral Pear	116	Wengué Wengue Wengue	103	Acacia Clair Acacia Clara Light Acacia	104	Acacia Foncé Acacia Oscura Dark Acacia
	007	Graphite Grafito Graphite	272	Chêne Veiné Castaño Claro Oak	273	Chêne Grisé Castaño Oscuro Dark Oak		





# star

Table haute avec structure métallique et repose-pieds central. STAR est une ampliation de la série STAR conçue pour simplifier la création d'un espace de travail.

Mesa alta con estructura metálica y reposapiés central. STAR nace fruto de la evolución de nuestro sistema de desarrollo y estudio. Con esta ampliación de la serie STAR se facilita el crear un espacio de trabajo más cómodo.

Metal frame high table with footrest. STAR is the result of an ongoing research and development system. This range make easier all kind of workspaces.

#### PLATEAU / SOBRE / DESK TOP

Mélamine / Melamina / Melamine: 25 mm  
Stratifié / Estratificado / Stratified: 25 mm

Chant en ABS / Canto ABS / ABS edges

#### STRUCTURE / ESTRUCTURA / FRAME

Acier: 50 x 50 x 1,8 mm  
Steel: 50 x 50 x 1,8 mm  
50  
prof./depth 80

#### FINITION STRUCTURE / ACABADO ESTRUCTURA / FRAME FINISH

Peinture époxy  
Pintura epoxi  
Epoxy paint

#### HAUTEUR / ALTURA / HEIGHT

105 cm

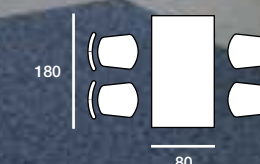

# MODÈLES | VARIANTES | VERSIONS















MODÈLE / VARIANTES / VERSIONS	TYPE / TIPO / TYPE	DIMENSIONS / MEDIDAS / MEASUREMENTS	RÉFÉRENCE / REFERENCIA / CODE
	Mixte / Mixta / Mixed	H 105 cm	<div style="display: flex; justify-content: space-around;"> <span>■</span> <span>■</span> <span>■</span> </div>
		180 x 80 cm	359.152.-..
		160 x 80 cm	359.153.-..
		120 x 80 cm	359.155.-..

Table haute  
Mesa alta  
High table

# FINITIONS | ACABADOS | FINISHES

STRUCTURE / ESTRUCTURA / FRAME | PLATEAU / SOBRE / DESK TOP

 Argent Plata Silver RAL 9006	 053 Blanc Blanco White	 054 Gris Gris Grey	 055 Hêtre Haya Beech	 061 Chêne Moyen Roble Maple
 Blanc Blanco White RAL 9016	 062 Poirier Peral Pear	 116 Wengué Wengue Wengue	 103 Acacia Clair Acacia Clara Light Acacia	 104 Acacia Foncé Acacia Oscura Dark Acacia
 Graphite Grafito Graphite RAL 7022	 007 Graphite Grafito Graphite	 272 Chêne Veiné Castaño Claro Oak	 273 Chêne Grisé Castaño Oscuro Dark Oak	

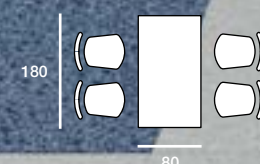

# tempo

Polyvalence et lignes épurées sont les principales caractéristiques de cette série. Elle nous permet de créer des espaces de travail avec une apparence légère et simple.

Versatilidad y simplicidad de formas son las características principales de esta serie. Se consiguen espacios diversos con formas ligeras y simples.

Versatility and simplicity on shapes are the main features of this range. Create different working spaces with light and simple looking.

## PLATEAU / SOBRE / DESK TOP

Mélamine / Melamina / Melamine: 25 mm  
Stratifié / Estratificado / Stratified: 25 mm

Chant en ABS / Canto ABS / ABS edges

## STRUCTURE / ESTRUCTURA / FRAME

Acier: 55 x 55 mm  
Steel:



## FINITION STRUCTURE / ACABADO ESTRUCTURA / FRAME FINISH

Peinture époxy  
Pintura epoxi  
Epoxy paint

## HAUTEUR / ALTURA / HEIGHT

105 cm

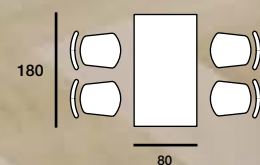

# MODÈLES | VARIANTES | VERSIONS

MODÈLE / VARIANTES / VERSIONS	TYPE / TIPO / TYPE	DIMENSIONS / MEDIDAS / MEASUREMENTS	RÉFÉRENCE / REFERENCIA / CODE
	Mixte / Mixta / Mixed	H 105 cm	<span style="display: inline-block; width: 10px; height: 10px; background-color: #808080; margin-right: 5px;"></span> <span style="display: inline-block; width: 10px; height: 10px; background-color: #f5f5dc; margin-right: 5px;"></span> <span style="display: inline-block; width: 10px; height: 10px; background-color: #202020;"></span>
		180 x 80 cm	389.101.-... 389.201.-... 389.301.-...
		160 x 80 cm	389.102.-... 389.202.-... 389.302.-...
		120 x 80 cm	389.104.-... 389.204.-... 389.304.-...

Table haute  
Mesa alta  
High table

# FINITIONS | ACABADOS | FINISHES

STRUCTURE / ESTRUCTURA / FRAME | PLATEAU / SOBRE / DESK TOP

 Argent Plata Silver RAL 9006	 053 Blanc Blanco White	 054 Gris Gris Grey	 055 Hêtre Haya Beech	 061 Chêne Moyen Roble Maple
 Blanc Blanco White RAL 9016	 062 Poirier Peral Pear	 116 Wengué Wengue Wengue	 103 Acacia Clair Acacia Clara Light Acacia	 104 Acacia Foncé Acacia Oscura Dark Acacia
 Graphite Grafito Graphite RAL 7022	 007 Graphite Grafito Graphite	 272 Chêne Veiné Castaño Claro Oak	 273 Chêne Grisé Castaño Oscuro Dark Oak	

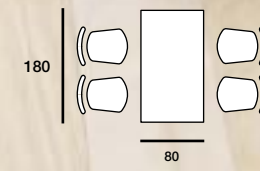

# MAX 1

Une série de style industriel idéale pour la collaboration. La combinaison esthétique de l'acier et de la mélamine passe parfaitement ensemble et offre une solution pratique et professionnelle.

Una serie de estilo industrial ideal para la colaboración. La combinación estética de acero y de melamina se entrelaza a la perfección para ofrecer una solución práctica y profesional.

Max is a high table with an industrial style, unique frame. The rectangular variant also includes a practical and useful shelf underneath the tabletop to stow personal items when having a formal or informal conversation.

## PLATEAU / SOBRE / DESK TOP

Mélamine / Melamina / Melamine: 25 mm  
Stratifié / Estratificado / Stratified: 25 mm

Chant en ABS / Canto ABS / ABS edges

## STRUCTURE / ESTRUCTURA / FRAME

Acier: Ø30 mm  
Acero: Ø30 mm  
Steel: Ø30 mm



## FINITION STRUCTURE / ACABADO ESTRUCTURA / FRAME FINISH

Peinture époxy  
Pintura epoxi  
Epoxy paint

## HAUTEUR / ALTURA / HEIGHT

105 cm

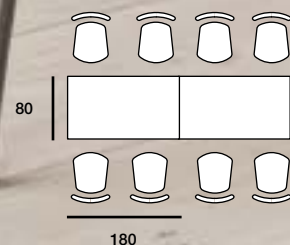

# MODÈLES | VARIANTES | VERSIONS

MODÈLE / VARIANTES / VERSIONS	TYPE / TIPO / TYPE	DIMENSIONS / MEDIDAS / MEASUREMENTS	RÉFÉRENCE / REFERENCIA / CODE
	Mixte / Mixta / Mixed	H 105 cm	<span style="display: inline-block; width: 10px; height: 10px; background-color: #808080; margin-right: 5px;"></span> <span style="display: inline-block; width: 10px; height: 10px; background-color: #f0f0f0; margin-right: 5px;"></span> <span style="display: inline-block; width: 10px; height: 10px; background-color: #333; margin-right: 5px;"></span>
		180 x 80 cm	709.152.---
		160 x 80 cm	709.153.---
		120 x 80 cm	709.155.---

Table haute  
Mesa alta  
High table

# FINITIONS | ACABADOS | FINISHES

STRUCTURE / ESTRUCTURA / FRAME | PLATEAU / SOBRE / DESK TOP

 Argent Plata Silver RAL 9006	 053 Blanc Blanco White	 054 Gris Gris Grey	 055 Hêtre Haya Beech	 061 Chêne Moyen Roble Maple
 Blanc Blanco White RAL 9016	 062 Poirier Peral Pear	 116 Wengué Wengue Wengue	 103 Acacia Clair Acacia Clara Light Acacia	 104 Acacia Foncé Acacia Oscura Dark Acacia
 Graphite Grafito Graphite RAL 7022	 007 Graphite Grafito Graphite	 272 Chêne Veiné Castaño Claro Oak	 273 Chêne Grisé Castaño Oscuro Dark Oak	

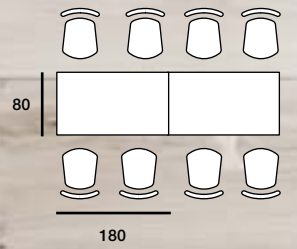

Tablette inférieure.  
Estante inferior.  
Bottom shelf.

# MAX 2

Une série de style industriel idéale pour la collaboration. La combinaison esthétique de l'acier et de la mélamine passe parfaitement ensemble et offre une solution pratique et professionnelle.

Una serie de estilo industrial ideal para la colaboración. La combinación estética de acero y de melamina se entrelaza a la perfección para ofrecer una solución práctica y profesional.

Max is a high table with an industrial style, unique frame. The rectangular variant also includes a practical and useful shelf underneath the tabletop to stow personal items when having a formal or informal conversation.

## PLATEAU / SOBRE / DESK TOP

Mélamine / Melamina / Melamine: 25 mm  
Stratifié / Estratificado / Stratified: 25 mm

Chant en ABS / Canto ABS / ABS edges

## STRUCTURE / ESTRUCTURA / FRAME

Acier: Ø30 mm  
Steel:



## FINITION STRUCTURE / ACABADO ESTRUCTURA / FRAME FINISH

Peinture époxy  
Pintura epoxi  
Epoxy paint

## HAUTEUR / ALTURA / HEIGHT

105 cm



# MODÈLES | VARIANTES | VERSIONS

MODÈLE / VARIANTES / VERSIONS	TYPE / TIPO / TYPE	DIMENSIONS / MEDIDAS / MEASUREMENTS		RÉFÉRENCE / REFERENCIA / CODE		
	Mixte / Mixta / Mixed	H 105 cm	Ø 100 cm Ø 80 cm	 709.176.-.- 709.177.-.-	 709.276.-.- 709.277.-.-	 709.376.-.- 709.377.-.-

Table haute ronde  
Mesa alta redonda  
Round high table

# FINITIONS | ACABADOS | FINISHES

STRUCTURE / ESTRUCTURA / FRAME | PLATEAU / SOBRE / DESK TOP

 Argent Plata Silver RAL 9006	 053 Blanc Blanco White	 054 Gris Grey	 055 Hêtre Haya Beech	 061 Chêne Moyen Roble Maple
 Blanc Blanco White RAL 9016	 062 Poirier Peral Pear	 116 Wengué Wengue Wengue	 103 Acacia Clair Acacia Clara Light Acacia	 104 Acacia Foncé Acacia Oscura Dark Acacia
 Graphite Grafito Graphite RAL 7022	 007 Graphite Grafito Graphite	 272 Chêne Veiné Castaño Claro Oak	 273 Chêne Grisé Castaño Oscuro Dark Oak	



Avec repose-pieds.  
Con reposapiés.  
With footrest.





# TAK

C'est une série de direction aux lignes droites et élégantes qui s'éloigne de tout ce qui est prétentieux.

Es una serie direccional que se armoniza para crear un sitio de trabajo funcional y práctico, de líneas rectas y puras en todo su conjunto.

TAK is a solid, straight lined and at the same time elegant looking executive range.

## PLATEAU / SOBRE / DESK TOP

Mélamine / Melamina / Melamine: 40 mm

Chant en ABS / Canto ABS / ABS edges

## STRUCTURE / ESTRUCTURA / FRAME

Mélamine / Melamina / Melamine:

40



## FINITION STRUCTURE / ACABADO ESTRUCTURA / FRAME FINISH

Mélamine  
Melamina  
Melamine

## HAUTEUR / ALTURA / HEIGHT

105 cm

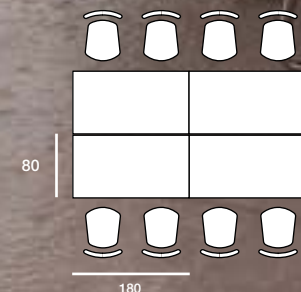

# MODÈLES | VARIANTES | VERSIONS

MODÈLE / VARIANTES / VERSIONS	TYPE / TIPO / TYPE	DIMENSIONS / MEDIDAS / MEASUREMENTS		RÉFÉRENCE / REFERENCIA / CODE
 <p>Table haute Mesa alta High table</p>	Structure en bois / Estructura de madera / Wood frame	H 105 cm	180 x 80 cm 160 x 80 cm 120 x 80 cm	569.105... 569.106... 569.108...

# FINITIONS | ACABADOS | FINISHES

053	Blanc Blanco White	103	Acacia Clair Acacia Clara Light Acacia	104	Acacia Foncé Acacia Oscura Dark Acacia	272	Chêne Veiné Castaño Claro Oak	273	Chêne Grisé Castaño Oscuro Dark Oak
-----	--------------------------	-----	--	-----	--	-----	-------------------------------------	-----	---

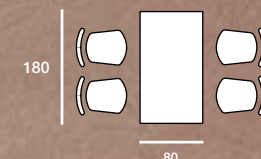

# ROCK 3

La série ROCK 3 se caractérise par son pied panneau mélaminé. Elle vous permet de meubler votre bureau au meilleur prix possible, avec une grande gamme de finitions.

ROCK 3 se caracteriza por un lateral tipo panel. Permite amueblar las oficinas al mejor precio, con gran variedad de acabados.

ROCK 3 melamine panel legs range is an affordable, high quality and stylish furniture, enabling customers to furnish their office space within a specific budget,



## PLATEAU / SOBRE / DESK TOP

Mélamine / Melamina / Melamine: 25 mm  
Stratifié / Estratificado / Stratified: 25 mm

Chant en ABS / Canto ABS / ABS edges

## STRUCTURE / ESTRUCTURA / FRAME

Mélamine / Melamina / Melamine:

25



## HAUTEUR / ALTURA / HEIGHT

105 cm



# MODÈLES | VARIANTES | VERSIONS

MODÈLE / VARIANTES / VERSIONS	TYPE / TIPO / TYPE	DIMENSIONS / MEDIDAS / MEASUREMENTS	RÉFÉRENCE / REFERENCIA / CODE
 <p>Table haute Mesa alta High table</p>	Structure en bois / Estructura de madera / Wood frame	H 105 cm 180 x 80 cm 160 x 80 cm 120 x 80 cm	439.101... 439.102... 439.104...

# FINITIONS | ACABADOS | FINISHES

053	Blanc Blanco White	054	Gris Gris Grey	055	Hêtre Haya Beech	061	Chêne Moyen Roble Maple	062	Poirier Peral Pear
116	Wengué Wengue Wengue	103	Acacia Clair Acacia Clara Light Acacia	104	Acacia Foncé Acacia Oscura Dark Acacia	007	Graphite Grafito Graphite	272	Chêne Veiné Castaño Claro Oak
273	Chêne Grisé Castaño Oscuro Dark Oak								

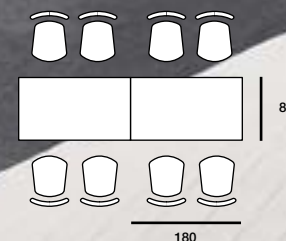

# ROL 1

Une série de tables hautes et de taille standard capables de s'adapter efficacement à de multiples espaces. Rol se caractérise par deux variantes importantes: table ronde (ROL 1) et table carrée (ROL 2).

Una serie de mesas altas y de medida estándar capaz de adaptarse eficazmente a múltiples espacios. Rol se caracteriza por disponer de dos variantes significativas: mesa redonda (ROL 1) y cuadrada (ROL 2).

Rol is a series of high and standard-size tables capable of effectively adapting to multiple spaces. Rol is characterized by having two significant variants: round (ROL 1) and square (ROL 2) table, each of them also available as high or low.

## PLATEAU / SOBRE / DESK TOP

Mélamine / Melamina / Melamine: 25 mm  
Stratifié / Estratificado / Stratified: 25 mm

Chant en ABS / Canto ABS / ABS edges

## STRUCTURE / ESTRUCTURA / FRAME

Acier: Ø114 mm  
Steel: 114



## FINITION STRUCTURE / ACABADO ESTRUCTURA / FRAME FINISH



Peinture époxy  
Pintura epoxi  
Epoxy paint

## HAUTEUR / ALTURA / HEIGHT

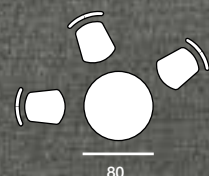
105 cm  
73 cm





# MODÈLES | VARIANTES | VERSIONS

MODÈLE / VARIANTES / VERSIONS	TYPE / TIPO / TYPE	DIMENSIONS / MEDIDAS / MEASUREMENTS		RÉFÉRENCE / REFERENCIA / CODE		
	Mixte / Mixta / Mixed	H 105 cm	Ø100 cm Ø80 cm	719.156-... 719.157-...	719.256-... 719.257-...	719.356-... 719.357-...
Table haute ronde Mesa alta redonda Round high table						
	Mixte / Mixta / Mixed	H 73 cm	Ø80 cm	719.167-...	719.267-...	719.367-...
Table H.73 Mesa H.73 H.73 Table						

# FINITIONS | ACABADOS | FINISHES

STRUCTURE / ESTRUCTURA / FRAME | PLATEAU / SOBRE / DESK TOP

 Argent Plata Silver RAL 9006	 Blanc Blanco White 053	 Gris Gris Grey 054	 Hêtre Haya Beech 055	 Chêne Moyen Roble Maple 061
 Blanc Blanco White RAL 9016	 Poirier Peral Pear 062	 Wengué Wengue Wengue 116	 Acacia Clair Acacia Clara Light Acacia 103	 Acacia Foncé Acacia Oscura Dark Acacia 104
 Graphite Grafito Graphite RAL 7022	 Graphite Grafito Graphite 007	 Chêne Veiné Castaño Claro Oak 272	 Chêne Grisé Castaño Oscuro Dark Oak 273	

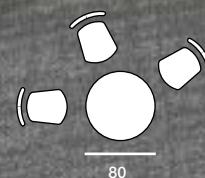

# ROL 2

Une série de tables hautes et de taille standard capables de s'adapter efficacement à de multiples espaces. Rol se caractérise par deux variantes importantes: table ronde (ROL 1) et table carrée (ROL 2).

Una serie de mesas altas y de medida estándar capaz de adaptarse eficazmente a múltiples espacios. Rol se caracteriza por disponer de dos variantes significativas: mesa redonda (ROL 1) y cuadrada (ROL 2).

Rol is a series of high and standard-size tables capable of effectively adapting to multiple spaces. Rol is characterized by having two significant variants: round (ROL 1) and square (ROL 2) table, each of them also available as high or low.

## PLATEAU / SOBRE / DESK TOP

Mélangine / Melamina / Melamine: 25 mm  
Stratifié / Estratificado / Stratified: 25 mm

Chant en ABS / Canto ABS / ABS edges

## STRUCTURE / ESTRUCTURA / FRAME

Acier: Ø114 mm  
Acero: Ø114 mm  
Steel: Ø114 mm



## FINITION STRUCTURE / ACABADO ESTRUCTURA / FRAME FINISH



Peinture époxy  
Pintura epoxi  
Epoxy paint

## HAUTEUR / ALTURA / HEIGHT

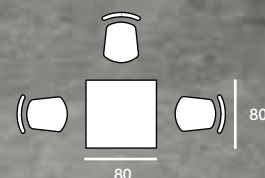
105 cm  
73 cm



# MODÈLES | VARIANTES | VERSIONS

MODÈLE / VARIANTES / VERSIONS	TYPE / TIPO / TYPE	DIMENSIONS / MEDIDAS / MEASUREMENTS		RÉFÉRENCE / REFERENCIA / CODE		
	Mixte / Mixta / Mixed	H 105 cm	100 x 100 cm 80 x 80 cm	719.176.-.- 719.177.-.-	719.276.-.- 719.277.-.-	719.376.-.- 719.377.-.-
Table haute Mesa alta High table						
	Mixte / Mixta / Mixed	H 73 cm	100 x 100 cm 80 x 80 cm	719.186.-.- 719.187.-.-	719.286.-.- 719.287.-.-	719.386.-.- 719.387.-.-
Table H.73 Mesa H.73 H.73 Table						

# FINITIONS | ACABADOS | FINISHES

STRUCTURE / ESTRUCTURA / FRAME | PLATEAU / SOBRE / DESK TOP

 RAL 9006	Argent Plata Silver	 053	Blanc Blanco White	 054	Gris Gris Grey	 055	Hêtre Haya Beech	 061	Chêne Moyen Roble Maple
 RAL 9016	Blanc Blanco White	 062	Poirier Peral Pear	 116	Wengué Wengue Wengue	 103	Acacia Clair Acacia Clara Light Acacia	 104	Acacia Foncé Acacia Oscura Dark Acacia
 RAL 7022	Graphite Grafito Graphite	 007	Graphite Grafito Graphite	 272	Chêne Veiné Castaño Claro Oak	 273	Chêne Grisé Castaño Oscuro Dark Oak		

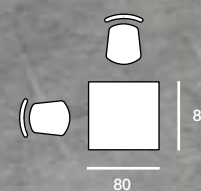



TABLES DE RÉUNION  
MESAS DE REUNIÓN  
MEETING TABLES



210 | UP



214 | STAR



218 | BORN



222 | TEMPO



226 | ECO



230 | SIGMA



234 | TONO



238 | TAK



244 | OPEN



248 | ROCK



254 | ROL 1



258 | ROL 2

# Up

Cette gamme de bureaux opératifs au design contemporain et futuriste existe en deux versions: fixe ou réglable. La version réglable électriquement permet d'ajuster la hauteur au besoin de l'utilisateur.

Mesa operativa con un diseño moderno y futurista. Hay dos modelos a escoger: la fija o la elevable. La mesa elevable dispone de un sistema eléctrico que permite adaptar la altura de la mesa según las necesidades del usuario.

This office table has a modern and futurist look. There are two options: fixed or height adjustable frame. Each user can choose its favorite table height lifting the desk with an electric engine.

## PLATEAU / SOBRE / DESK TOP

Mélamine / Melamina / Melamine: 25 mm  
Stratifié / Estratificado / Stratified: 13 mm  
Phénolique / Fenolico / Phenolic: 13 mm

Chant en ABS / Canto ABS / ABS edges

## STRUCTURE / ESTRUCTURA / FRAME

Acier: 70 x 70 x 2 mm  
Acero: 70 x 70 x 2 mm  
Steel: 70 x 70 x 2 mm

## FINITION STRUCTURE / ACABADO ESTRUCTURA / FRAME FINISH

Peinture époxy  
Pintura epoxi  
Epoxy paint





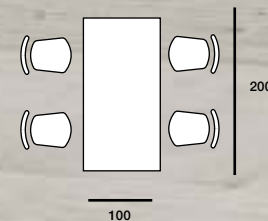









## HAUTEUR / ALTURA / HEIGHT

73 mm



# MODÈLES | VARIANTES | VERSIONS

HAUTEUR FIXE / FIJAS / FIXED HEIGHT

MODÈLE / VARIANTES / VERSIONS	DIMENSIONS / MEDIDAS / MEASUREMENTS	RÉFÉRENCE / REFERENCIA / CODE		
 <p>Table de réunion rectangulaire Mesa de reunión rectangular Rectangular meeting table</p>	220 x 100 cm 200 x 100 cm	 594.100.-...  594.200.-...  594.300.-...	 594.101.-...  594.201.-...  594.301.-...	
 <p>Table de réunion forme tonneau Mesa de reunión tonel Barrel meeting table</p>	220 x 100 cm 200 x 100 cm	 594.110.-...  594.210.-...  594.310.-...	 594.111.-...  594.211.-...  594.311.-...	

# FINITIONS | ACABADOS | FINISHES

STRUCTURE / ESTRUCTURA / FRAME | PLATEAU / SOBRE / DESKTOP

 Argent Plata Silver <small>RAL 9006</small>	 053 Blanc Blanco White	 054 Gris Gris Grey	 055 Hêtre Haya Beech	 061 Chêne Moyen Roble Maple
 Blanc Blanco White <small>RAL 9016</small>	 062 Poirier Peral Pear	 116 Wengué Wengue Wengue	 103 Acacia Clair Acacia Clara Light Acacia	 104 Acacia Foncé Acacia Oscura Dark Acacia
 Graphite Grafito Graphite <small>RAL 7022</small>	 007 Graphite Grafito Graphite	 272 Chêne Veiné Castaño Claro Oak	 273 Chêne Gris Castaño Oscuro Dark Oak	



# star

La gamme STAR est le fruit de l'évolution de nos recherches et système de développement.

STAR es, sin duda, una apuesta de futuro en el desarrollo y evolución del mobiliario de oficina. Fruto de la evolución del sistema de desarrollo y estudio, nace este programa.

STAR is the future in office furniture. It was born as a result of ongoing research and development systems.

## PLATEAU / SOBRE / DESK TOP

Mélamine / Melamina / Melamine: 25 mm  
Stratifié / Estratificado / Stratified: 25 mm  
Phénolique / Fenólico / Phenolic: 13 mm

Chant en ABS / Canto ABS / ABS edges

## STRUCTURE / ESTRUCTURA / FRAME

Acier: 60 x 60 x 1,5 mm  
Steel: 60 x 60 x 1,5 mm



## FINITION STRUCTURE / ACABADO ESTRUCTURA / FRAME FINISH

Peinture époxy  
Pintura epoxi  
Epoxy paint

## HAUTEUR / ALTURA / HEIGHT

73 mm

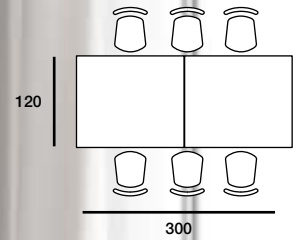









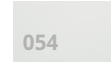

# MODÈLES | VARIANTES | VERSIONS

PIÉTEMENT OUVERT / PATA ABIERTA / U-SHAPE LEG

MODÈLE / VARIANTES / VERSIONS	DIMENSIONS / MEDIDAS / MEASUREMENTS	RÉFÉRENCE / REFERENCIA / CODE		
 <p>Tables de réunion Mesas de reunión Meeting tables</p>	450 x 120 cm	354.104.---	354.204.---	354.304.---
	300 x 120 cm	354.103.---	354.203.---	354.303.---
	250 x 120 cm	354.102.---	354.202.---	354.302.---
	200 x 120 cm	354.101.---	354.201.---	354.301.---
	120 x 120 cm	354.100.---	354.200.---	354.300.---
	480 x 160 cm	354.107.---	354.207.---	354.307.---
	320 x 160 cm	354.106.---	354.206.---	354.306.---
	160 x 160 cm	354.105.---	354.205.---	354.305.---

# FINITIONS | ACABADOS | FINISHES

STRUCTURE / ESTRUCTURA / FRAME | PLATEAU / SOBRE / DESKTOP

 Argent Plata Silver <small>RAL 9006</small>	 053 Blanc Blanco White	 054 Gris Gris Grey	 055 Hêtre Haya Beech	 061 Chêne Moyen Roble Maple
 Blanc Blanco White <small>RAL 9016</small>	 062 Poirier Peral Pear	 116 Wengué Wengue Wengue	 103 Acacia Clair Acacia Clara Light Acacia	 104 Acacia Foncé Acacia Oscura Dark Acacia
 Graphite Grafito Graphite <small>RAL 7022</small>	 007 Graphite Grafito Graphite	 272 Chêne Veiné Castaño Claro Oak	 273 Chêne Grisé Castaño Oscuro Dark Oak	

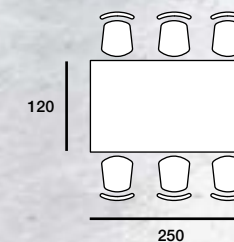

# BORN

Un bureau au style nordique est possible avec la série BORN. Un design pratique et chaleureux qui répond à toutes les exigences pour créer des espaces calmes, ordonnés, propres et fonctionnels.

Una oficina con estilo nórdico es posible con la serie BORN. Un diseño práctico y cálido que reúne todos los requisitos para crear espacios tranquilos, ordenados, limpios y funcionales.



An office with Nordic style is possible with the BORN series. A practical and warm design due to the wooden legs and therefore able to create serene, neat, and useful spaces.

## PLATEAU / SOBRE / DESKTOP

Mélamine / Melamina / Melamine: 25 mm

Chant en ABS / Canto ABS / ABS edges

## STRUCTURE / ESTRUCTURA / FRAME

Bois:	60 x 60 mm - 60 x 30 mm	60	
Madera:		30	
Wood:			
Acier:	50 x 30 x 2 mm	50	
Acero:		30	
Steel:			
Mixte:	50 x 30 x 2 mm	50	
Mixta:		30	
Steel+Wood:			

## FINITION STRUCTURE / ACABADO ESTRUCTURA / FRAME FINISH

Bois ou peinture époxy  
Madera o pintura epoxi  
Wood or epoxy paint

## HAUTEUR / ALTURA / HEIGHT

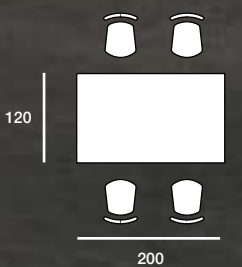

73 mm



# MODÈLES | VARIANTES | VERSIONS

MODÈLE / VARIANTES / VERSIONS	TYPE / TIPO / TYPE	DIMENSIONS / MEDIDAS / MEASUREMENTS	RÉFÉRENCE / REFERENCIA / CODE
	Métallique / Metal / Metal	450 x 120 cm 300 x 120 cm 250 x 120 cm 200 x 120 cm 120 x 120 cm	 634.104.-.- 634.204.-.- 634.304.-.- 634.103.-.- 634.203.-.- 634.303.-.- 634.102.-.- 634.202.-.- 634.302.-.- 634.101.-.- 634.201.-.- 634.301.-.- 634.100.-.- 634.200.-.- 634.300.-.-
	Mixte / Mixta / Metal + Wood	450 x 120 cm 300 x 120 cm 250 x 120 cm 200 x 120 cm 120 x 120 cm	 634.604.-.- 634.704.-.- 634.804.-.- 634.603.-.- 634.703.-.- 634.803.-.- 634.602.-.- 634.702.-.- 634.802.-.- 634.601.-.- 634.701.-.- 634.801.-.- 634.600.-.- 634.700.-.- 634.800.-.-

**Tables de réunion**  
Mesas de reunión  
Meeting tables

	En bois / Madera / Wood	450 x 120 cm 300 x 120 cm 241 x 120 cm 200 x 120 cm 120 x 120 cm	 634.504.-.- 634.503.-.- 634.502.-.- 634.501.-.- 634.500.-.-
---	-------------------------	--	--

**Tables de réunion**  
Mesas de reunión  
Meeting tables

# FINITIONS | ACABADOS | FINISHES

STRUCTURE / ESTRUCTURA / FRAME | PLATEAU / SOBRE / DESKTOP

 Argent Plata Silver	 Argent + Hêtre Plata + Haya Silver + Beech veneer	 Hêtre Haya Beech veneer	 053 Blanc Blanco White	 054 Gris Gris Grey	 055 Hêtre Haya Beech
 Blanc Blanco White	 Blanc + Hêtre Blanco + Haya White + Beech veneer		 061 Chêne Moyen Roble Maple	 062 Poirier Peral Pear	 116 Wengué Wengue Wengue
 Graphite Grafito Graphite	 Graphite + Hêtre Grafito + Haya Graphite + Beech veneer		 103 Acacia Clair Acacia Clara Light Acacia	 104 Acacia Foncé Acacia Oscura Dark Acacia	 007 Graphite Grafito Graphite
			 272 Chêne Veiné Castaño Claro Oak	 273 Chêne Grisé Castaño Oscuro Dark Oak	

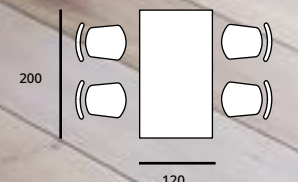

# tempo

Polyvalence et lignes épurées sont les principales caractéristiques de cette série. Elle nous permet de créer des espaces de travail avec une apparence légère et simple.

Versatilidad y simplicidad de formas son las características principales de esta serie. Se consiguen espacios diversos con formas ligeras y simples.

Versatility and simplicity on shapes are the main features of this range. Create different working spaces with light and simple looking.

## PLATEAU / SOBRE / DESK TOP

Mélamine / Melamina / Melamine: 25 mm  
Chant en ABS / Canto ABS / ABS edges

## STRUCTURE / ESTRUCTURA / FRAME

Acier: 55  
Acero: 55 mm x 55 mm x 1,5 mm  
Steel: 55  
□ 1,5

## FINITION STRUCTURE / ACABADO ESTRUCTURA / FRAME FINISH

Peinture époxy  
Pintura epoxi  
Epoxy paint

## HAUTEUR / ALTURA / HEIGHT

Fixe: 73 mm  
Fija: 73 mm  
Fixed: 73 mm  
Réglable: 80,6 > 63 mm  
Regulable: 80,6 > 63 mm  
Adjustable: 80,6 > 63 mm

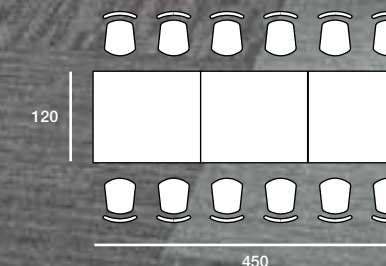



# MODÈLES | VARIANTES | VERSIONS

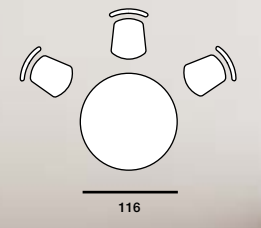

MODÈLE / VARIANTES / VERSIONS	DIMENSIONS / MEDIDAS / MEASUREMENTS	RÉFÉRENCE / REFERENCIA / CODE	
	450 x 120 cm 300 x 120 cm	H. fixe / fija / fixed 384.050.-.- 384.055.-.-	H. réglable / regulable / adjustable 384.150.-.- 384.155.-.-
	250 x 120 cm 200 x 120 cm 120 x 120 cm	384.021.-.- 384.022.-.- 384.026.-.-	384.121.-.- 384.122.-.- 384.126.-.-
	Ø 116 cm	404.132.-.-	

Tables de réunion  
Mesas de reunión  
Meeting tables

# FINITIONS | ACABADOS | FINISHES

STRUCTURE / ESTRUCTURA / FRAME | PLATEAU / SOBRE / DESK TOP

	060 Blanc Blanco White	064 Gris Gris Grey	065 Hêtre Haya Beech	066 Chêne Moyen Roble Maple	067 Poirier Peral Pear
	068 Wengué Wengue Wengue	706 Acacia Clair Acacia Clara Light Acacia	707 Acacia Foncé Acacia Oscura Dark Acacia	020 Graphite Grafito Graphite	031 Chêne Veiné Castaño Claro Oak
	032 Chêne Gris Castaño Oscuro Dark Oak				
	096 Blanc Blanco White	097 Gris Gris Grey	098 Hêtre Haya Beech	099 Chêne Moyen Roble Maple	100 Poirier Peral Pear
	101 Wengué Wengue Wengue	709 Acacia Clair Acacia Clara Light Acacia	710 Acacia Foncé Acacia Oscura Dark Acacia	017 Graphite Grafito Graphite	166 Chêne Veiné Castaño Claro Oak
	167 Chêne Gris Castaño Oscuro Dark Oak				
	163 Blanc Blanco White	180 Gris Gris Grey	181 Hêtre Haya Beech	182 Chêne Moyen Roble Maple	183 Poirier Peral Pear
	184 Wengué Wengue Wengue	715 Acacia Clair Acacia Clara Light Acacia	716 Acacia Foncé Acacia Oscura Dark Acacia	113 Graphite Grafito Graphite	206 Chêne Veiné Castaño Claro Oak
	208 Chêne Gris Castaño Oscuro Dark Oak				

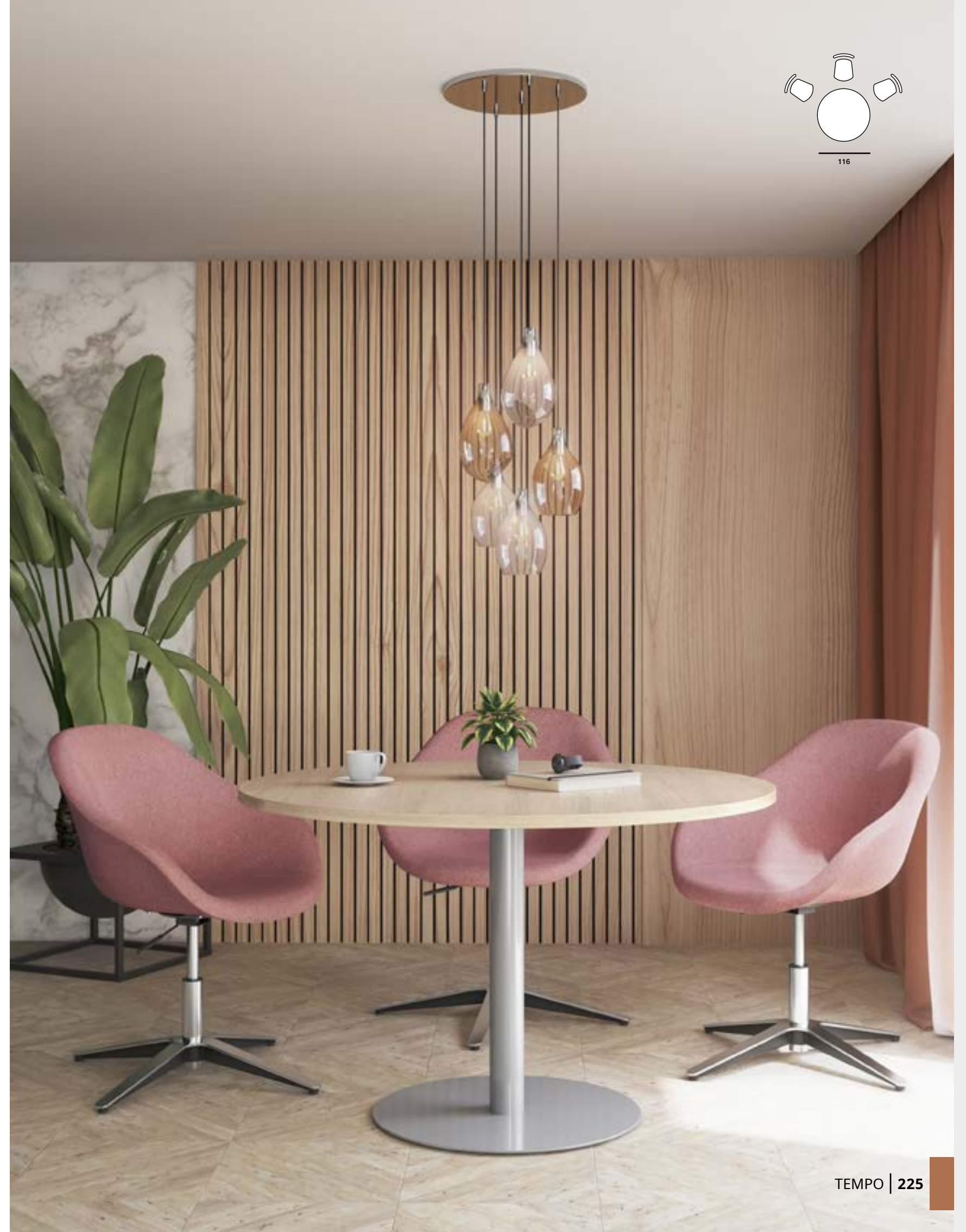

# ECO

ECO, une série modulaire et polyvalente résolument adaptée aux besoins du marché.

Culminación de esfuerzos encaminados a satisfacer las necesidades de trabajo más exigentes.

This range is the result of many efforts seeking to meet the most demanding working needs from the simplicity of shapes and design.

## PLATEAU / SOBRE / DESK TOP

Mélamine / Melamina / Melamine:  
Stratifié / Estratificado / Stratified: 25 mm

Chant en ABS / Canto ABS / ABS edges

## STRUCTURE / ESTRUCTURA / FRAME

Acier  
Acero  
Steel 60 x 60 x 2 mm



## FINITION STRUCTURE / ACABADO ESTRUCTURA / FRAME FINISH



Peinture époxy  
Pintura epoxi  
Epoxy paint

## HAUTEUR / ALTURA / HEIGHT

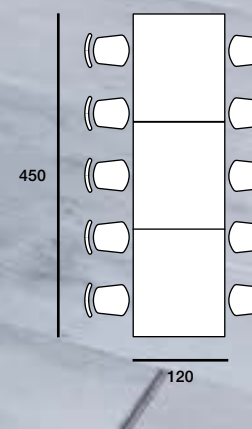
73 mm





# MODÈLES | VARIANTES | VERSIONS

MODÈLE / VARIANTES / VERSIONS	DIMENSIONS / MEDIDAS / MEASUREMENTS	RÉFÉRENCE / REFERENCIA / CODE
	450 x 120 cm 300 x 120 cm	394.050.-.- 394.055.-.-
	250 x 120 cm 200 x 120 cm 120 x 120 cm	394.021.-.- 394.022.-.- 394.026.-.-
	Ø 116 cm	404.132.-.-

Tables de réunion  
Mesas de reunión  
Meeting tables

# FINITIONS | ACABADOS | FINISHES

STRUCTURE / ESTRUCTURA / FRAME | PLATEAU / SOBRE / DESK TOP

	060 Blanc Blanco White	064 Gris Gris Grey	065 Hêtre Haya Beech	066 Chêne Moyen Roble Maple	067 Poirier Peral Pear
	068 Wengué Wengue Wengue	706 Acacia Clair Acacia Clara Light Acacia	707 Acacia Foncé Acacia Oscura Dark Acacia	020 Graphite Grafito Graphite	031 Chêne Veiné Castaño Claro Oak
	032 Chêne Grisé Castaño Oscuro Dark Oak				
	096 Blanc Blanco White	097 Gris Gris Grey	098 Hêtre Haya Beech	099 Chêne Moyen Roble Maple	100 Poirier Peral Pear
	101 Wengué Wengue Wengue	709 Acacia Clair Acacia Clara Light Acacia	710 Acacia Foncé Acacia Oscura Dark Acacia	017 Graphite Grafito Graphite	166 Chêne Veiné Castaño Claro Oak
	167 Chêne Grisé Castaño Oscuro Dark Oak				

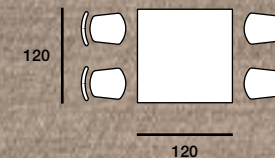

# sigma

SIGMA améliore votre poste de travail grâce à ses nouveaux concepts ergonomiques et esthétiques.

SIGMA mejora los puestos de trabajo aportándoles nuevos conceptos ergonómicos y estéticos.

SIGMA improves workplaces by its ergonomics features and design concepts.



## PLATEAUX / SOBRE / DESK TOP

Mélamine / Melamina / Melamine: 25 mm  
Chant en ABS / Canto ABS / ABS edges

## STRUCTURE / ESTRUCTURA / FRAME

Acier:  
Acero:  
Steel: 920 x 920 mm

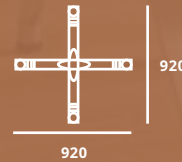

## FINITION STRUCTURE / ACABADO ESTRUCTURA / FRAME FINISH

Peinture époxy  
Pintura epoxi  
Epoxy paint

## HAUTEUR / ALTURA / HEIGHT

73 mm

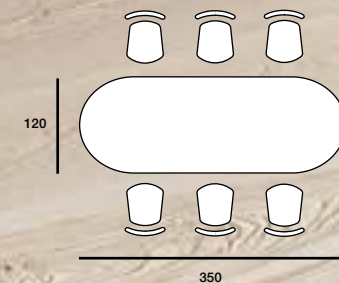

# MODÈLES | VARIANTES | VERSIONS

MODÈLE / VARIANTES / VERSIONS	DIMENSIONS / MEDIDAS / MEASUREMENTS	RÉFÉRENCE / REFERENCIA / CODE
	500 x 120 cm 450 x 120 cm 400 x 120 cm 350 x 120 cm 300 x 120 cm	234.104.-... 234.106.-... 234.108.-... 234.110.-... 234.112.-...
	250 x 120 cm 200 x 120 cm	234.114.-... 234.116.-...
	Ø 130 cm Ø 116 cm	234.118.-... 234.120.-...

Tables de réunion  
Mesas de reunión  
Meeting tables

# FINITIONS | ACABADOS | FINISHES

STRUCTURE / ESTRUCTURA / FRAME | PLATEAU / SOBRE / DESK TOP

	060 Blanc Blanco White	064 Gris Gris Grey	065 Hêtre Haya Beech	066 Chêne Moyen Roble Maple	067 Poirier Peral Pear
	068 Wengué Wengue Wengue	706 Acacia Clair Acacia Clara Light Acacia	707 Acacia Foncé Acacia Oscura Dark Acacia	020 Graphite Grafito Graphite	031 Chêne Veiné Castaño Claro Oak
	032 Chêne Grisé Castaño Oscuro Dark Oak				
	096 Blanc Blanco White	097 Gris Gris Grey	098 Hêtre Haya Beech	099 Chêne Moyen Roble Maple	100 Poirier Peral Pear
	101 Wengué Wengue Wengue	709 Acacia Clair Acacia Clara Light Acacia	710 Acacia Foncé Acacia Oscura Dark Acacia	017 Graphite Grafito Graphite	166 Chêne Veiné Castaño Claro Oak
	167 Chêne Grisé Castaño Oscuro Dark Oak				
	163 Blanc Blanco White	180 Gris Gris Grey	181 Hêtre Haya Beech	182 Chêne Moyen Roble Maple	183 Poirier Peral Pear
	184 Wengué Wengue Wengue	715 Acacia Clair Acacia Clara Light Acacia	716 Acacia Foncé Acacia Oscura Dark Acacia	113 Graphite Grafito Graphite	206 Chêne Veiné Castaño Claro Oak
	208 Chêne Grisé Castaño Oscuro Dark Oak				



# tono

Large éventail de styles et compositions  
avec un minimum de références.

Con esta serie se obtiene una gran versatilidad  
de estilos y composiciones  
con un número reducido de referencias.

Great variety of styles and compositions within  
the same range and easy to order.



## PLATEAU / SOBRE / DESK TOP

Mélamine / Melamina / Melamine: 25 mm  
Chant en ABS / Canto ABS / ABS edges

## STRUCTURE / ESTRUCTURA / FRAME

Mélamine 2,5 / 1,9 cm  
Melamina  
Melamine 67,5 cm

## HAUTEUR / ALTURA / HEIGHT

73 mm

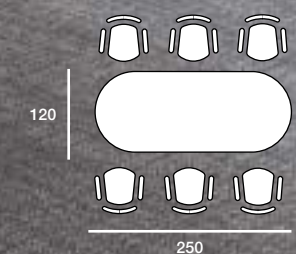

# MODÈLES | VARIANTES | VERSIONS

MODÈLE / VARIANTES / VERSIONS	DIMENSIONS / MEDIDAS / MEASUREMENTS	RÉFÉRENCE / REFERENCIA / CODE
 Table de réunion rectangulaire Mesa de reunión rectangular Rectangular meeting table	250 x 120 cm 200 x 120 cm	604.001.-.- 604.002.-.-
 Table de réunion ovale Mesa de reunión ovalada Oval meeting table	250 x 120 cm 200 x 120 cm	604.003.-.- 604.004.-.-

# FINITIONS | ACABADOS | FINISHES

STRUCTURE / ESTRUCTURA / FRAME | PLATEAU / SOBRE / DESK TOP

Argent Plata Silver	075	Blanc Blanco White	054	Gris Grey	055	Hêtre Haya Beech	061	Chêne Moyen Roble Maple	062	Poirier Peral Pear
	116	Wengué Wengue Wengue	694	Acacia Clair Acacia Clara Light Acacia	695	Acacia Foncé Acacia Oscura Dark Acacia	115	Graphite Grafito Graphite	272	Chêne Veiné Castaño Claro Oak
	273	Chêne Grisé Castaño Oscuro Dark Oak								
Blanc Blanco White	081	Blanc Blanco White	076	Gris Grey	077	Hêtre Haya Beech	078	Chêne Moyen Roble Maple	079	Poirier Peral Pear
	080	Wengué Wengue Wengue	168	Acacia Clair Acacia Clara Light Acacia	169	Acacia Foncé Acacia Oscura Dark Acacia	125	Graphite Grafito Graphite	043	Chêne Veiné Castaño Claro Oak
	106	Chêne Grisé Castaño Oscuro Dark Oak								

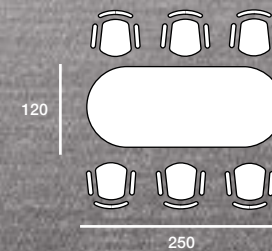

# TAK

C'est une série de direction aux lignes droites et élégantes qui s'éloigne de tout ce qui est prétentieux.

Es una serie direccional que se armoniza para crear un sitio de trabajo funcional y práctico, de líneas rectas y puras en todo su conjunto.

TAK is a solid, straight lined and at the same time elegant looking executive range.

## PLATEAU / SOBRE / DESK TOP

Mélamine / Melamina / Melamine: 40 mm

Chant en ABS / Canto ABS / ABS edges

## STRUCTURE / ESTRUCTURA / FRAME

Mélamine / Melamina / Melamine:

40

## FINITION STRUCTURE / ACABADO ESTRUCTURA / FRAME FINISH

Mélamine ou bois vernis  
Melamina o madera barnizada  
Melamine or wood veneer

## HAUTEUR / ALTURA / HEIGHT

73 mm

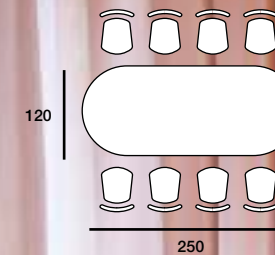



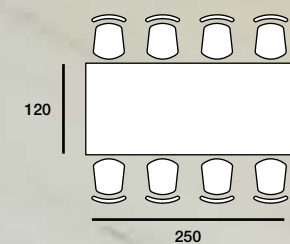

## MODÈLES | VARIANTES | VERSIONS



MODÈLE / VARIANTES / VERSIONS	DIMENSIONS / MEDIDAS / MEASUREMENTS	RÉFÉRENCE / REFERENCIA / CODE	
	600 x 120 cm	Mélamine Melamina Melamine	Noyer Américain Nogal Americano American Walnut
	400 x 120 cm	564.202.-.-	564.702.365
	300 x 120 cm	564.208.-.-	564.708.365
	250 x 120 cm	564.212.-.-	564.712.365
	200 x 120 cm	564.214.-.-	564.714.365
	120 x 120 cm	564.216.-.-	564.716.365
564.218.-.-	564.718.365		

Table de réunion rectangulaire  
Mesa de reunión rectangular  
Rectangular meeting table



	600 x 120 cm	Mélamine Melamina Melamine	Noyer Américain Nogal Americano American Walnut
	400 x 120 cm	564.102.-.-	564.402.365
	300 x 120 cm	564.108.-.-	564.408.365
	250 x 120 cm	564.112.-.-	564.412.365
	200 x 120 cm	564.114.-.-	564.414.365
	Ø 130 cm	564.116.-.-	564.416.365
		564.118.-.-	564.418.365

Table de réunion ovale  
Mesa de reunión ovalada  
Oval meeting table

## FINITIONS | ACABADOS | FINISHES

Monochrome Monocolor Single-colour	053	Blanc Blanco White	103	Acacia Clair Acacia Clara Light Acacia	104	Acacia Foncé Acacia Oscura Dark Acacia
	272	Chêne Veiné Castaño Claro Oak	273	Chêne Grisé Castaño Oscuro Dark Oak		Noyer Américain Nogal Americano American Walnut

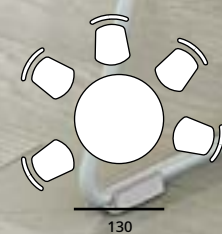

# open

Les besoins actuels de nos centres de travail ont évolué techniquement afin de satisfaire et de s'adapter à notre époque.

Las necesidades actuales en los centros de trabajo han evolucionado técnicamente para satisfacer y adaptarse a estos tiempos.

Current needs at work places have technically developed in order to satisfy us and to adjust to our present time.

## PLATEAU / SOBRE / DESK TOP

Stratifiés / Estratificado / Stratified: 40 mm

## STRUCTURE / ESTRUCTURA / FRAME

Aluminium anodisé:  
Aluminio anodizado:  
Anodised aluminium:

110 x 30 mm



## FINITION STRUCTURE / ACABADO ESTRUCTURA / FRAME FINISH

Peinture époxy  
Pintura epoxi  
Epoxy paint



Bain de chrome  
Baño cromado  
Chrome

## HAUTEUR / ALTURA / HEIGHT

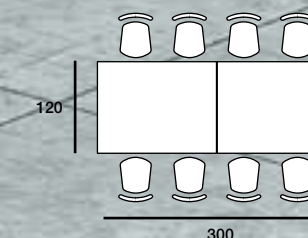
73 mm







## MODÈLES | VARIANTES | VERSIONS

MODÈLE / VARIANTES / VERSIONS	DIMENSIONS / MEDIDAS / MEASUREMENTS	RÉFÉRENCE / REFERENCIA / CODE
	514 x 120 cm 436 x 120 cm 400 x 120 cm 350 x 120 cm 300 x 120 cm	344.104... 344.106... 344.108... 344.110... 344.112...
	240 x 120 cm 200 x 120 cm	344.114... 344.116...
	Ø 116 cm Ø 130 cm	344.194... 344.192...

Tables de réunion  
Mesas de reunión  
Meeting tables

## FINITIONS | ACABADOS | FINISHES

STRUCTURE / ESTRUCTURA / FRAME | PLATEAU / SOBRE / DESK TOP

 Blanc Blanco White <small>RAL 9016</small>	 144 Blanc Blanco White	 145 Acacia Clair Acacia Clara Light Acacia	 146 Acacia Foncé Acacia Oscura Dark Acacia
 Chromée Cromado Chrome	 148 Blanc Blanco White	 149 Acacia Clair Acacia Clara Light Acacia	 150 Acacia Foncé Acacia Oscura Dark Acacia

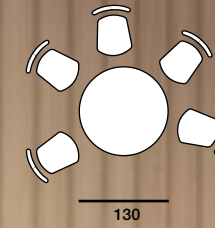

# ROCK

Rock est synonyme de modernité et d'élégance. Cette série transmet une impression de légèreté, mais sa robustesse est garantie.

Elle se caractérise par sa colonne d'acier disponible en trois finitions.

Rock es sinónimo de modernidad y elegancia. Transmite una impresión de ligereza, pero su robustez esta asegurada técnicamente. Se caracteriza por su pie columna disponible en tres versiones de acabados.

Rock range is synonymous with modernity and elegance.

It conveys a light-weight image but has a strong and stable structure.

The stylised pole legs are the prevalent characteristic of this desk, available in three finishes.

## PLATEAU / SOBRE / DESK TOP

Mélamine / Melamina / Melamine: 25 mm  
Stratifié / Estratificado / Stratified: 25 mm

Chant en ABS / Canto ABS / ABS edges

## STRUCTURE / ESTRUCTURA / FRAME

Acier: Ø75 mm  
Steel:



## FINITION STRUCTURE / ACABADO ESTRUCTURA / FRAME FINISH

Peinture époxy  
Pintura epoxi  
Epoxy paint

## HAUTEUR / ALTURA / HEIGHT

70 mm

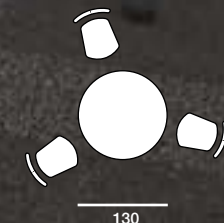

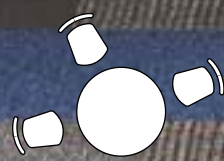

# MODÈLES | VARIANTES | VERSIONS





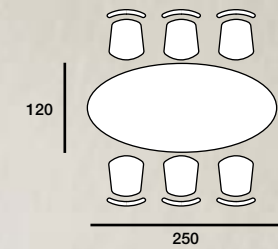



















MODÈLE / VARIANTES / VERSIONS	DIMENSIONS / MEDIDAS / MEASUREMENTS	RÉFÉRENCE / REFERENCIA / CODE
	600 x 120 cm 450 x 120 cm	404.108. --- 404.112. ---
	300 x 120 cm 350 x 120 cm 400 x 120 cm	404.118. --- 404.116. --- 404.114. ---
	250 x 120 cm 200 x 120 cm	404.120. --- 404.122. ---
	Ø 130 cm Ø 116 cm	404.130. --- 404.132. ---

Tables de réunion  
Mesas de reunión  
Meeting tables



# FINITIONS | ACABADOS | FINISHES

STRUCTURE / ESTRUCTURA / FRAME | PLATEAU / SOBRE / DESK TOP

 Argent Plata Silver RAL 9006	 060 Blanc Blanco White	 064 Gris Gris Grey	 065 Hêtre Haya Beech	 066 Chêne Moyen Roble Maple	 067 Poirier Peral Pear	 068 Wengué Wengue Wengue
 Blanc Blanco White RAL 9016	 706 Acacia Clair Acacia Clara Light Acacia	 707 Acacia Foncé Acacia Oscura Dark Acacia	 020 Graphite Grafito Graphite	 031 Chêne Veiné Castaño Claro Oak	 032 Chêne Grisé Castaño Oscuro Dark Oak	
	 096 Blanc Blanco White	 097 Gris Gris Grey	 098 Hêtre Haya Beech	 099 Chêne Moyen Roble Maple	 100 Poirier Peral Pear	 101 Wengué Wengue Wengue
	 709 Acacia Clair Acacia Clara Light Acacia	 710 Acacia Foncé Acacia Oscura Dark Acacia	 017 Graphite Grafito Graphite	 166 Chêne Veiné Castaño Claro Oak	 167 Chêne Grisé Castaño Oscuro Dark Oak	



# ROL 1

Une série de tables de taille standard capables de s'adapter efficacement à de multiples espaces. Rol se caractérise par deux variantes importantes: table ronde et table carrée.

Una serie de mesas de medida estándar capaz de adaptarse eficazmente a múltiples espacios. Rol se caracteriza por disponer de dos variantes significativas: mesa redonda y cuadrada.

Rol standard-size tables capable of effectively adapting to multiple spaces. Rol is characterized by having two significant variants: round and square table, each of them also available as high or low.

## PLATEAU / SOBRE / DESK TOP

Mélamine / Melamina / Melamine: 25 mm  
Stratifié / Estratificado / Stratified: 25 mm

Chant en ABS / Canto ABS / ABS edges

## STRUCTURE / ESTRUCTURA / FRAME

Acier: Ø114 mm  
Steel:



## FINITION STRUCTURE / ACABADO ESTRUCTURA / FRAME FINISH

Peinture époxy  
Pintura epoxi  
Epoxy paint

## HAUTEUR / ALTURA / HEIGHT

73 cm

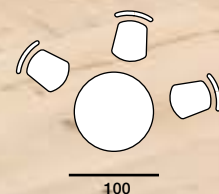



# MODÈLES | VARIANTES | VERSIONS

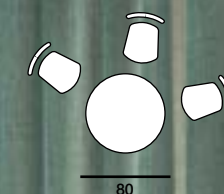

MODÈLE / VARIANTES / VERSIONS	TYPE / TIPO / TYPE	DIMENSIONS / MEDIDAS / MEASUREMENTS	RÉFÉRENCE / REFERENCIA / CODE		
	Mixte / Mixta / Mixed	Ø100 cm Ø80 cm	719.166.--- 719.167.---	719.266.--- 719.267.---	719.366.--- 719.367.---

Tables de réunion  
Mesas de reunión  
Meeting tables

# FINITIONS | ACABADOS | FINISHES

STRUCTURE / ESTRUCTURA / FRAME | PLATEAU / SOBRE / DESKTOP

Argent Plata Silver RAL 9006	053 Blanc Blanco White	054 Gris Gris Grey	055 Hêtre Haya Beech	061 Chêne Moyen Roble Maple
Blanc Blanco White RAL 9016	062 Poirier Peral Pear	116 Wengué Wengue Wengue	103 Acacia Clair Acacia Clara Light Acacia	104 Acacia Foncé Acacia Oscura Dark Acacia
Graphite Grafito Graphite RAL 7022	007 Graphite Grafito Graphite	272 Chêne Veiné Castaño Claro Oak	273 Chêne Grisé Castaño Oscuro Dark Oak	



# ROL 2

Une série de tables de taille standard capables de s'adapter efficacement à de multiples espaces. Rol se caractérise par deux variantes importantes: table ronde et table carrée.

Una serie de medida estándar capaz de adaptarse eficazmente a múltiples espacios. Rol se caracteriza por disponer de dos variantes significativas: mesa redonda y cuadrada.

Rol standard-size tables capable of effectively adapting to multiple spaces. Rol is characterized by having two significant variants: round and square table, each of them also available as high or low.

## PLATEAUX / SOBRE / DESK TOP

Mélamine / Melamina / Melamine: 25 mm  
Stratifié / Estratificado / Stratified: 25 mm

Chant en ABS / Canto ABS / ABS edges

## STRUCTURE / ESTRUCTURA / FRAME

Acero: Ø114 mm  
Steel:



## FINITION STRUCTURE / ACABADO ESTRUCTURA / FRAME FINISH







Peinture époxy  
Pintura epoxi  
Epoxy paint

## HAUTEUR / ALTURA / HEIGHT

73 cm





# MODÈLES | VARIANTES | VERSIONS

MODÈLE / VARIANTES / VERSIONS	TYPE / TIPO / TYPE	DIMENSIONS / MEDIDAS / MEASUREMENTS	RÉFÉRENCE / REFERENCIA / CODE		
	Mixte / Mixta / Mixed	100 x 100 cm 80 x 80 cm	 719.186...  719.187...	 719.286...  719.287...	 719.386...  719.387...

Tables de réunion  
Mesas de reunión  
Meeting tables

# FINITIONS | ACABADOS | FINISHES

STRUCTURE / ESTRUCTURA / FRAME | PLATEAU / SOBRE / DESKTOP

 Argent Plata Silver RAL 9006	 Blanc Blanco White RAL 9016	 Graphite Grafito Graphite RAL 7022	 053 Blanc Blanco White	 054 Gris Gris Grey	 055 Hêtre Haya Beech	 061 Chêne Moyen Roble Maple
	 062 Poirier Peral Pear	 116 Wengué Wengue Wengue	 103 Acacia Clair Acacia Clara Light Acacia	 104 Acacia Foncé Acacia Oscura Dark Acacia		
	 007 Graphite Grafito Graphite	 272 Chêne Veiné Castaño Claro Oak	 273 Chêne Grisé Castaño Oscuro Dark Oak			

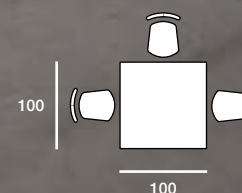

TABLES BASSES  
MESAS DE CENTRO  
COFFEE TABLES



**264** | BROS



**270** | ROCK 3



**276** | SERIE 82



**282** | TAK



**288** | ROL

# BROS

Cette table basse est la cerise sur le gâteau de la famille de chaises Bros. Sa forme organique en bois et métal apporte de la légèreté dans les salles d'attente, les réceptions et les sièges polyvalents.

Esta mesa de centro es la guinda del pastel de la familia de sillas Bros. Su forma orgánica compuesta en madera y metal aporta ligereza en salas de espera, recepciones y zonas polivalentes de soft seating.

This coffee table is very stylish and elegant due to the organic shape of its frame and the round edged top. It brings refinement to waiting rooms, receptions and multi-purpose soft seating areas.

## PLATEAU / SOBRE / DESK TOP

Mélamine / Melamina / Melamine: 19 mm

Chant en ABS / Canto ABS / ABS edges

## STRUCTURE / ESTRUCTURA / FRAME

Aceir: Ø15 mm  
Acero:  
Steel:



## FINITION STRUCTURE / ACABADO ESTRUCTURA / FRAME FINISH

Peinture époxy  
Pintura epoxi  
Epoxy paint

## HAUTEUR / ALTURA / HEIGHT

38,7 cm

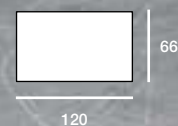

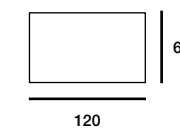
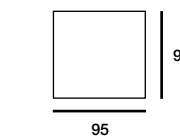
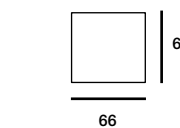

## MODÈLES | VARIANTES | VERSIONS

STRUCTURE ACEIR / ESTRUCTURA ACERO / STEEL FRAME





















MODÈLE / VARIANTES / VERSIONS	DIMENSIONS / MEDIDAS / MEASUREMENTS	RÉFÉRENCE / REFERENCIA / CODE
	66 x 66 cm	 57.041... 57.141... 57.241... 57.341...
	95 x 95 cm	57.042... 57.142... 57.242... 57.342...
	120 x 66 cm	57.040... 57.140... 57.240... 57.340...

Table basse  
Mesa centro  
Coffee table

## FINITIONS | ACABADOS | FINISHES

STRUCTURE / ESTRUCTURA / FRAME | PLATEAU / SOBRE / DESKTOP

 Noir Negro Black RAL 9005	 053 Blanc Blanco White	 054 Gris Gris Grey	 055 Hêtre Haya Beech	 061 Chêne Moyen Roble Maple
 Blanc Blanco White RAL 9016	 062 Poirier Peral Pear	 116 Wengué Wengue Wengue	 103 Acacia Clair Acacia Clara Light Acacia	 104 Acacia Foncé Acacia Oscura Dark Acacia
 Argent Plata Silver RAL 9006	 007 Graphite Grafito Graphite	 272 Chêne Veiné Castaño Claro Oak	 273 Chêne Grisé Castaño Oscuro Dark Oak	 028 Noir Negro Black
 Graphite Grafito Graphite RAL 7022				

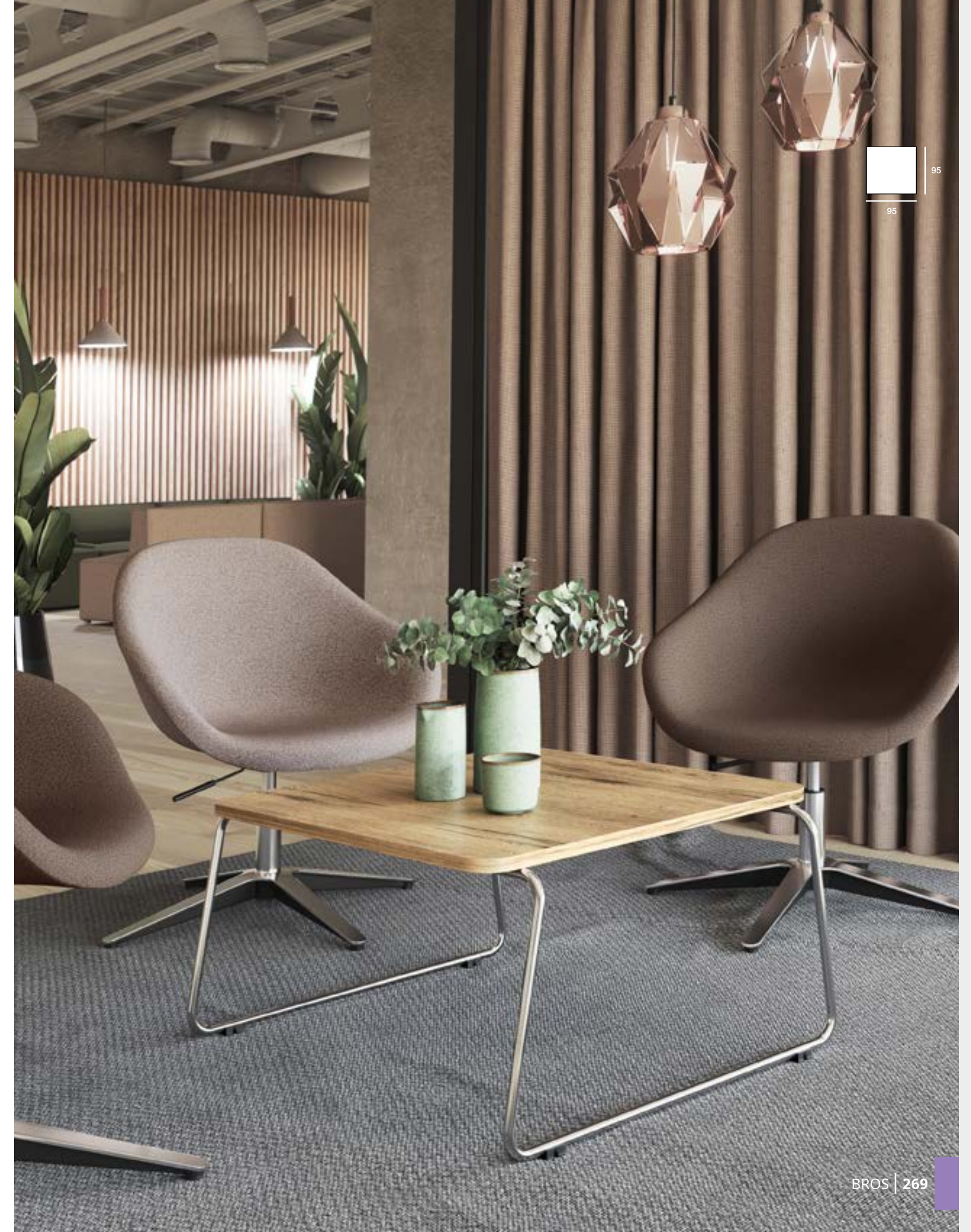

# ROCK 3

Une version de ROCK 3 pour accompagner les espaces de sièges moelleux. Corp et prestance pour une table basse conforme aux normes.

Una versión de ROCK 3 para acompañar espacios de soft seating. Cuerpo y presencia para una mesa de centro que cumple con las normativas.

Rock 3 coffee table for soft seating spaces. Uncomplicated and no-nonsense design that complies with the regulations.

## PLATEAU / SOBRE / DESK TOP

Mélamine / Melamina / Melamine: 25 mm

Chant en ABS / Canto ABS / ABS edges

## STRUCTURE / ESTRUCTURA / FRAME

Mélamine / Melamina / Melamine

25

## FINITION STRUCTURE / ACABADO ESTRUCTURA / FRAME FINISH

Mélamine  
Melamina  
Melamine

## HAUTEUR / ALTURA / HEIGHT

35 cm





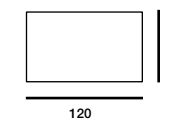
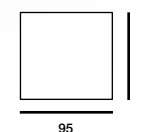
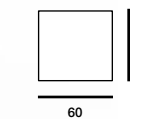
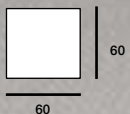

# MODÈLES | VARIANTES | VERSIONS

STRUCTURE MÉLAMINE / ESTRUCTURA DE MELAMINA / MELAMINE FRAME



MODÈLE / VARIANTES / VERSIONS	DIMENSIONS / MEDIDAS / MEASUREMENTS	RÉFÉRENCE / REFERENCIA / CODE
	60 x 60 cm	431.317.-..
	95 x 95 cm	431.316.-..
	120 x 60 cm	431.315.-..

Table basse  
Mesa centro  
Coffee table

# FINITIONS | ACABADOS | FINISHES

053	Blanc Blanco White	054	Gris Gris Grey	055	Hêtre Haya Beech	061	Chêne Moyen Roble Maple	062	Poirier Peral Pear
116	Wengué Wengue Wengue	103	Acacia Clair Acacia Clara Light Acacia	104	Acacia Foncé Acacia Oscura Dark Acacia	007	Graphite Grafito Graphite	272	Chêne Veiné Castaño Claro Oak
273	Chêne Gris Castaño Oscuro Dark Oak								



# SERIE 82

La série 82, est une table basse classique pour équiper tous les espaces. Sa structure avec des courbes lui donne un caractère léger et simple.

Serie 82, es una mesa de centro clásica con la que equipar todo tipo de espacios. Su estructura en curva le concede un carácter ligero y sencillo.

Series 82 is a classic coffee table with which to equip waiting rooms or soft seating areas. Its curved structure gives it a vintage and mature character.

## PLATEAU / SOBRE / DESK TOP

Mélamine / Melamina / Melamine: 19 mm

Chant en ABS / Canto ABS / ABS edges

## STRUCTURE / ESTRUCTURA / FRAME

Acier: 30 x 15 mm  
Steel:



## FINITION STRUCTURE / ACABADO ESTRUCTURA / FRAME FINISH

Peinture époxy  
Pintura epoxi  
Epoxy paint

## HAUTEUR / ALTURA / HEIGHT

39 cm



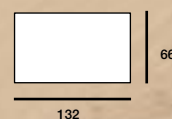
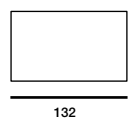
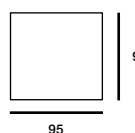
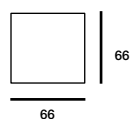

# MODÈLES | VARIANTES | VERSIONS

## STRUCTURE ACEIR / ESTRUCTURA ACERO / STEEL FRAME







MODÈLE / VARIANTES / VERSIONS	DIMENSIONS / MEDIDAS / MEASUREMENTS	RÉFÉRENCE / REFERENCIA / CODE	
	66 x 66 cm	 82.910.-.-	 82.920.-.-
	95 x 95 cm	82.950.-.-	82.960.-.-
	132 x 66 cm	82.930.-.-	82.940.-.-

Table basse  
Mesa centro  
Coffee table

# FINITIONS | ACABADOS | FINISHES

## STRUCTURE / ESTRUCTURA / FRAME | PLATEAU / SOBRE / DESKTOP

 Noir Negro Black <small>RAL 9005</small>	 054 Gris Gris Grey	 055 Hêtre Haya Beech	 061 Chêne Moyen Roble Maple	 062 Poirier Peral Pear
 Chromée Cromado Chrome	 007 Graphite Grafito Graphite	 116 Wengué Wengue Wengue	 103 Acacia Clair Acacia Clara Light Acacia	 104 Acacia Foncé Acacia Oscura Dark Acacia
	 272 Chêne Veiné Castaño Claro Oak	 273 Chêne Grisé Castaño Oscuro Dark Oak		

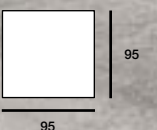

# TAK

Une réplique en petit mais tout aussi sobre. Ses lignes droites et l'épaisseur de ses matériaux mettent en valeur les espaces dans lesquels il est présenté. Les finitions métalliques qui séparent la structure du plateau ajoutent de l'air et rehaussent son design.

Una réplica en pequeño pero igual de sobria. Sus líneas rectas y el grosor de su cuerpo realzan los espacios en los que se presenta. Los acabados metálicos que separan la estructura del sobre aportan aire y elevan su diseño.

A replica of the executive desk but in small. Its straight lines and the solidity of its body magnifies the space in which it is placed. The chrome details that separate the panels from the top provides quality and prestige.

## PLATEAU / SOBRE / DESK TOP

Mélamine / Melamina / Melamine: 40 mm

Chant en ABS / Canto ABS / ABS edges

## STRUCTURE / ESTRUCTURA / FRAME

Mélamine / Melamina / Melamine:



## FINITION STRUCTURE / ACABADO ESTRUCTURA / FRAME FINISH

Mélamine ou bois vernis  
Melamina o madera barnizada  
Melamine or wood veneer

## HAUTEUR / ALTURA / HEIGHT

40,2 cm



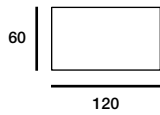
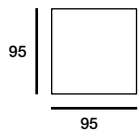
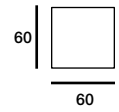

## MODÈLES | VARIANTES | VERSIONS



MODÈLE / VARIANTES / VERSIONS	DIMENSIONS / MEDIDAS / MEASUREMENTS	RÉFÉRENCE / REFERENCIA / CODE
	60 x 60 cm	Mélamine Melamina Melamine 561.116... 561.416.365 Noyer Américain Nogal Americano American Walnut
	95 x 95 cm	561.117... 561.417.365
	120 x 60 cm	561.115... 561.415.365

Table basse  
Mesa centro  
Coffee table

## FINITIONS | ACABADOS | FINISHES

Monochrome  
Monocolor  
Single-colour

053	Blanc Blanco White	103	Acacia Clair Acacia Clara Light Acacia	104	Acacia Foncé Acacia Oscura Dark Acacia	272	Chêne Veiné Castaño Claro Oak
273	Chêne Grisé Castaño Oscuro Dark Oak		Noyer Américain Nogal Americano American Walnut				





# ROL

La simplicité de cette table basse transforme les pauses et les réunions informelles en rencontres dynamiques, collaboratives et efficaces.

La simplicidad desenfadada de esta mesa de centro convierte los descansos y las reuniones informales en encuentros dinámicos, colaborativos y efectivos.

The simplicity of this round coffee table turns breaks and informal meetings into relaxed and easygoing encounters.

## PLATEAU / SOBRE / DESK TOP

Mélamine / Melamina / Melamine: 25 mm  
Stratifié / Estratificado / Stratified: 25 mm

Chant en ABS / Canto ABS / ABS edges

## STRUCTURE / ESTRUCTURA / FRAME

Acier: Ø114 mm  
Steel:



114

## FINITION STRUCTURE / ACABADO ESTRUCTURA / FRAME FINISH

Peinture époxy  
Pintura epoxi  
Epoxy paint

## HAUTEUR / ALTURA / HEIGHT

44,5 cm  
45 cm



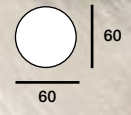
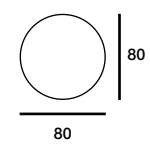
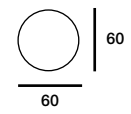

# MODÈLES | VARIANTES | VERSIONS

STRUCTURE ACEIR / ESTRUCTURA ACERO / STEEL FRAME













MODÈLE / VARIANTES / VERSIONS	DIMENSIONS / MEDIDAS / MEASUREMENTS		RÉFÉRENCE / REFERENCIA / CODE		
	H 44,5 cm	Ø80 cm	 719.159.-..	 719.259.-..	 719.359.-..
	H 45 cm	Ø60 cm	719.168.-..	719.268.-..	719.368.-..

Table basse  
Mesa centro  
Coffee table

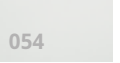
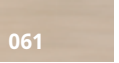
# FINITIONS | ACABADOS | FINISHES

STRUCTURE / ESTRUCTURA / FRAME | PLATEAU / SOBRE / DESKTOP

 Argent Plata Silver RAL 9006	 053 Blanc Blanco White	 054 Gris Gris Grey	 055 Hêtre Haya Beech	 061 Chêne Moyen Roble Maple
 Blanc Blanco White RAL 9016	 062 Poirier Peral Pear	 116 Wengué Wengue Wengue	 103 Acacia Clair Acacia Clara Light Acacia	 104 Acacia Foncé Acacia Oscura Dark Acacia
 Graphite Grafito Graphite RAL 7022	 007 Graphite Grafito Graphite	 272 Chêne Veiné Castaño Claro Oak	 273 Chêne Grisé Castaño Oscuro Dark Oak	



CLOISONS  
MAMPARAS  
SCREENS



296 | RB



308 | CALL



318 | ROCK SYSTEMS



326 | NEKTA

# RB

RB est une série de cloisons modulaires qui favorise l'organisation et la définition des espaces de travail et qui s'adapte aux défis de la vie quotidienne. Il se présente comme une solution organisatrice et génératrice capable de créer un équilibre entre différents espaces, avec plus ou moins d'intimité.

RB es una serie de mamparas modulares que favorece la organización y la definición de los espacios de trabajo adecuándose a los retos del día a día. Se presenta como una solución organizadora y generadora de ambientes capaz de crear equilibrio entre distintos espacios, con mayor o menor nivel de privacidad.

RB is an innovative office partition system that helps to divide workplaces in a flexible and ingenious way. RB partitions have an attractive framework that can be integrated into all furniture ranges and build areas that simplify people teamwork. Contribute to business results by taking care of workers in a peaceful company.

## FINITION CLOISONS / ACABADOS MAMPARA / SCREEN FINISHES

Mélamine / Melamina / Melamine  
Tissu / Tapizado / Upholstered  
Acoustique / Acústico / Acoustic

## HAUTEUR / ALTURA / HEIGHT

Fixe:  
Fija: 41'5, 73, 81, 120, 158, 196, 235 cm  
Fixed:

MODULES AVEC  
DIFFÉRENTES  
HAUTEURS

COMPOSICIÓN  
DE DIFERENTES  
ALTURAS

DIFFERENT  
HEIGHTS  
COMPOSITION

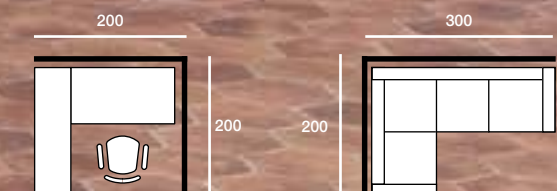



| MULTI PANNEAUX

| MULTIPANEL

| TILED

Ensemble de cloisons droites.  
 Conjunto de mamparas rectas.  
 Straight screens set.

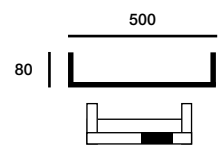

| UN SEUL PANNEAU

| MONOPANEL

| MONOLITHIC

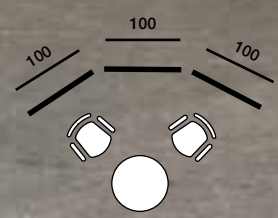

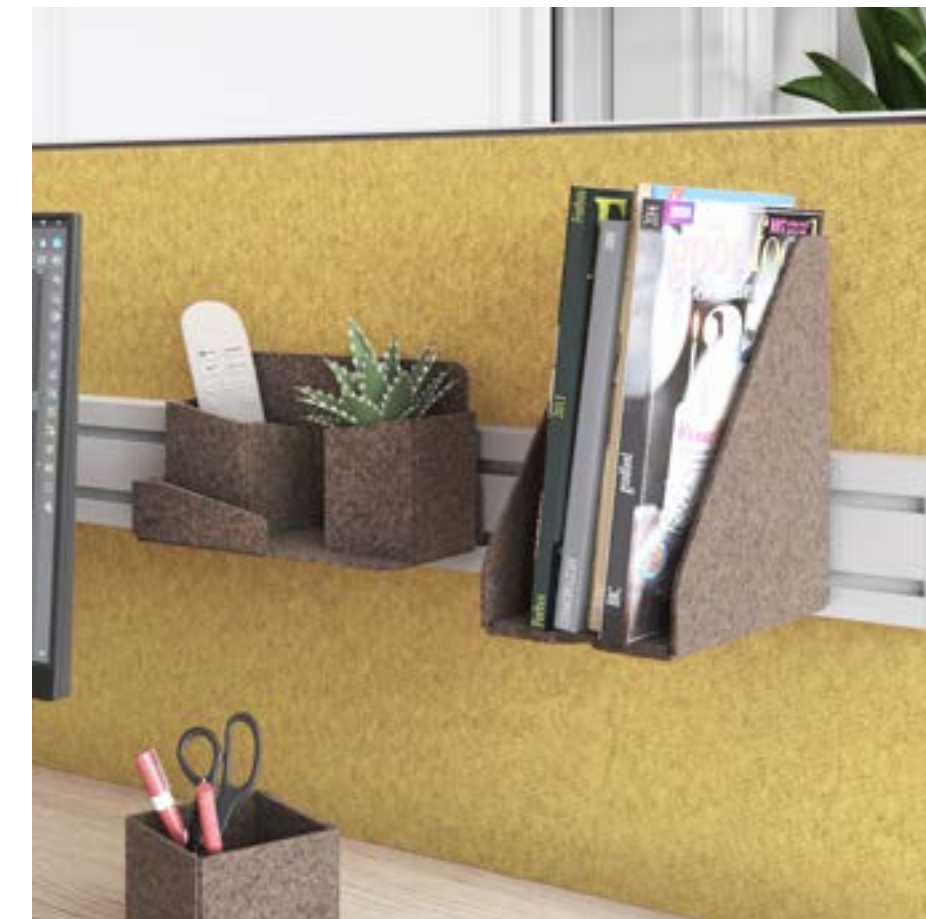
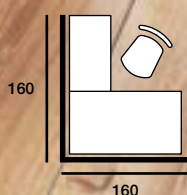

Accessoires en PET.  
Complementos de PET.  
PET accessories.





Ardoise magnétique blanche.  
Pizarra magnética blanca.  
White magnetic board.



Compléments en mélamine, étagères suspendues.  
Complementos de melamina, estantes.  
Melamine accessories, shelves.

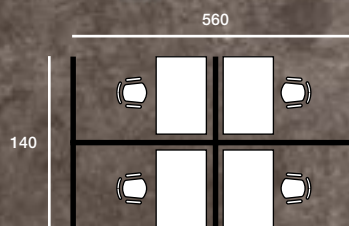

Compléments métalliques, penderie.  
Complementos metálicos, perchero.  
Metal accessories, coat-bar.



300

100

# call

Cette série, très adaptée pour l'aménagement des centres d'appels, est très fonctionnelle et optimise l'espace de travail au maximum en apportant confort et commodité à l'utilisateur.

Representa la optimización del espacio de trabajo. Con unos conceptos de funcionalidad que permiten al usuario gestionar de forma eficaz su confort en su puesto de trabajo.

It represents the optimization in working spaces. Thanks to its functionality concept, users will be able to manage more efficiently their working places.

## PLATEAU / SOBRE / DESK TOP

Mélamine / Melamina / Melamine: 25 mm

## FINITION CLOISONS / ACABADOS MAMPARA / SCREEN FINISHES

Mélamine / Melamina / Melamine  
Tissu / Tapizado / Upholstered  
Acoustique / Acústico / Acoustic  
Méthacrylate / Metacrilato / Methacrylate

## HAUTEUR / ALTURA / HEIGHT

Table:		Cloisons:	
Mesa:	73 cm	Paneles:	121 - 140 cm
Desk:		Screens:	

INDIVIDUEL  
OU ALIGNÉ

INDIVIDUAL  
O EN LÍNEA

SINGLE OR  
SIDE BY SIDE

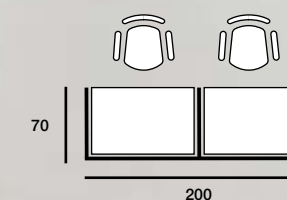

| MARGUERITES

| MARGARITAS

| CLUSTERS

Acoustique  
Acústico  
Acoustic

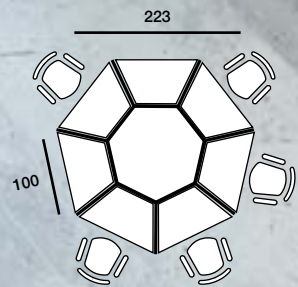

| DOUBLE

| DOBLE

| FACE TO FACE

Les cloisonnettes acoustiques vous aideront à contrôler le bruit excessif.  
Con los plafones separadores acústicos se reduce el nivel de ruido.  
Acoustic panels help to reduce the noise of the room.

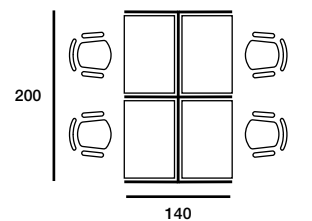

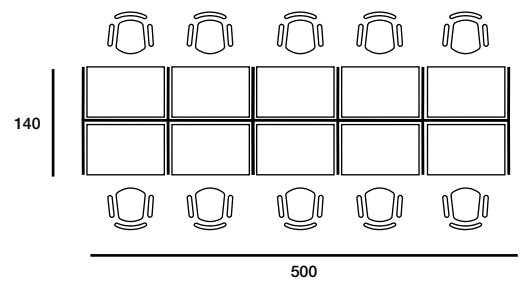

| DOUBLE

| DOBLE

| FACE TO FACE



# MODÈLES | VARIANTES | VERSIONS

MODÈLE / VARIANTES / VERSIONS	TYPE / TIPO / TYPE	DIMENSIONS / MEDIDAS / MEASUREMENTS	RÉFÉRENCE / REFERENCIA / CODE	
	Modules: / Módulos de: / Moduls of:		19mm	25mm
	H.120 cm	100 x 70 cm 80 x 70 cm	807.314.-.- 807.315.-.-	807.214.-.- 807.215.-.-
<b>Individual terminal</b> Individual terminal Single start unit	H.140 cm	100 x 70 cm 80 x 70 cm	807.304.-.- 807.305.-.-	807.204.-.- 807.205.-.-
	H.120 cm	100 x 70 cm 80 x 70 cm	807.334.-.- 807.335.-.-	807.234.-.- 807.235.-.-
<b>Individual central</b> Individual central Single add-on unit	H.140 cm	100 x 70 cm 80 x 70 cm	807.324.-.- 807.325.-.-	807.224.-.- 807.225.-.-
	H.120 cm	100 x 140 cm 80 x 140 cm	807.364.-.- 807.365.-.-	807.264.-.- 807.265.-.-
<b>En vis à vis terminal</b> Enfrentados terminal Face to face start unit	H.140 cm	100 x 140 cm 80 x 140 cm	807.354.-.- 807.355.-.-	807.254.-.- 807.255.-.-
	H.120 cm	100 x 140 cm 80 x 140 cm	807.384.-.- 807.385.-.-	807.284.-.- 807.285.-.-
<b>En vis à vis central</b> Enfrentados central Face to face add-on unit	H.140 cm	100 x 140 cm 80 x 140 cm	807.374.-.- 807.375.-.-	807.274.-.- 807.275.-.-
	H.120 cm	1400 x 70 + 100 cm 1400 x 70 + 80 cm	807.366.-.- 807.367.-.-	807.266.-.- 807.267.-.-
<b>En vis à vis avec superviseur</b> Enfrentados con supervisor Face to face with supervisor	H.140 cm	1400 x 70 + 100 cm 1400 x 70 + 80 cm	807.356.-.- 807.357.-.-	807.256.-.- 807.257.-.-
	5P: H.120 cm H.140 cm	100 X 157 cm 100 X 157 cm	807.408.-.- 807.407.-.-	
<b>Marguerite</b> Margarita Cluster	7P: H.120 cm H.140 cm	100 X 157 cm 100 X 157 cm	807.404.-.- 807.403.-.-	

## FINITIONS ACABADOS FINISHES

<b>096</b> Blanc Blanco White	<b>064</b> Gris Gris Grey	<b>065</b> Hêtre Haya Beech	<b>113</b> Graphite Grafito Graphite
<b>066</b> Chêne Moyen Roble Maple	<b>067</b> Poirier Peral Pear	<b>068</b> Wengué Wengue Wengue	<b>095</b> Argent Plata Silver
<b>706</b> Acacia Clair Acacia Clara Light Acacia	<b>707</b> Acacia Foncé Acacia Oscura Dark Acacia	<b>272</b> Chêne Veiné Castaño Claro Oak	<b>273</b> Chêne Grisé Castaño Oscuro Dark Oak

# MODÈLES | VARIANTES | VERSIONS

MODÈLE / VARIANTES / VERSIONS	TYPE / TIPO / TYPE	DIMENSIONS / MEDIDAS / MEASUREMENTS	RÉFÉRENCE / REFERENCIA / CODE	
	Modules: / Módulos de: / Moduls of:		19mm	25mm
	H.120 cm	100 x 70 cm 80 x 70 cm	807.214.-.- 807.215.-.-	
<b>Individual terminal</b> Individual terminal Single start unit	H.140 cm	100 x 70 cm 80 x 70 cm	807.204.-.- 807.205.-.-	
	H.120 cm	100 x 70 cm 80 x 70 cm	807.234.-.- 807.235.-.-	
<b>Individual central</b> Individual central Single add-on unit	H.140 cm	100 x 70 cm 80 x 70 cm	807.224.-.- 807.225.-.-	
	H.120 cm	100 x 140 cm 80 x 140 cm	807.264.-.- 807.265.-.-	
<b>En vis à vis terminal</b> Enfrentados terminal Face to face start unit	H.140 cm	100 x 140 cm 80 x 140 cm	807.254.-.- 807.255.-.-	
	H.120 cm	100 x 140 cm 80 x 140 cm	807.284.-.- 807.285.-.-	
<b>En vis à vis central</b> Enfrentados central Face to face add-on unit	H.140 cm	100 x 140 cm 80 x 140 cm	807.274.-.- 807.275.-.-	
	H.120 cm	1400 x 70 + 100 cm 1400 x 70 + 80 cm	807.266.-.- 807.267.-.-	
<b>En vis à vis avec superviseur</b> Enfrentados con supervisor Face to face with supervisor	H.140 cm	1400 x 70 + 100 cm 1400 x 70 + 80 cm	807.256.-.- 807.257.-.-	
	5P: H.120 cm H.140 cm	100 X 157 cm 100 X 157 cm	807.408.-.- 807.407.-.-	
<b>Marguerite</b> Margarita Cluster	7P: H.120 cm H.140 cm	100 X 157 cm 100 X 157 cm	807.404.-.- 807.403.-.-	

## FINITIONS ACABADOS FINISHES

<b>818</b> Blanc Blanco White	<b>819</b> Gris Gris Grey	<b>820</b> Hêtre Haya Beech	<b>816</b> Graphite Grafito Graphite
<b>821</b> Chêne Moyen Roble Maple	<b>822</b> Poirier Peral Pear	<b>823</b> Wengué Wengue Wengue	<b>817</b> Argent Plata Silver
<b>824</b> Acacia Clair Acacia Clara Light Acacia	<b>825</b> Acacia Foncé Acacia Oscura Dark Acacia	<b>025</b> Chêne Veiné Castaño Claro Oak	<b>026</b> Chêne Grisé Castaño Oscuro Dark Oak

# FINITIONS | ACABADOS | FINISHES

## CLOISONS / MAMPARA / SCREEN | PLATEAU / SOBRE / DESK TOP







<b>053</b> Blanc Blanco White	<b>054</b> Gris Gris Grey	<b>055</b> Hêtre Haya Beech	<b>061</b> Chêne Moyen Roble Maple	<b>062</b> Poirier Peral Pear	<b>116</b> Wengué Wengue Wengue
<b>103</b> Acacia Clair Acacia Clara Light Acacia	<b>104</b> Acacia Foncé Acacia Oscura Dark Acacia	<b>007</b> Graphite Grafito Graphite	<b>051</b> Argent Plata Silver	<b>272</b> Chêne Veiné Castaño Claro Oak	<b>273</b> Chêne Grisé Castaño Oscuro Dark Oak

## CLOISONS / MAMPARA / SCREEN | PLATEAU / SOBRE / DESK TOP

<b>792</b> Blanc Blanco White	<b>799</b> Gris Gris Grey	<b>802</b> Hêtre Haya Beech	<b>803</b> Chêne Moyen Roble Maple	<b>811</b> Poirier Peral Pear	<b>812</b> Wengué Wengue Wengue
<b>813</b> Acacia Clair Acacia Clara Light Acacia	<b>814</b> Acacia Foncé Acacia Oscura Dark Acacia	<b>790</b> Graphite Grafito Graphite	<b>791</b> Argent Plata Silver	<b>025</b> Chêne Veiné Castaño Claro Oak	<b>026</b> Chêne Grisé Castaño Oscuro Dark Oak



# MODÈLES | VARIANTES | VERSIONS

MODÈLE / VARIANTES / VERSIONS	TYPE / TIPO / TYPE	DIMENSIONS / MEDIDAS / MEASUREMENTS	RÉFÉRENCE / REFERENCIA / CODE
	Modules: / Módulos de: / Moduls of:		19mm 25mm
	H.120 cm	100 x 70 cm 80 x 70 cm	807.214.-.- 807.215.-.-
<b>Individuel terminal</b> Individual terminal Single start unit	H.140 cm	100 x 70 cm 80 x 70 cm	807.204.-.- 807.205.-.-
	H.120 cm	100 x 70 cm 80 x 70 cm	807.234.-.- 807.235.-.-
	H.140 cm	100 x 70 cm 80 x 70 cm	807.224.-.- 807.225.-.-
	H.120 cm	100 x 70 cm 80 x 70 cm	807.234.-.- 807.235.-.-
<b>Individuel central</b> Individual central Single add-on unit	H.120 cm	100 x 140 cm 80 x 140 cm	807.264.-.- 807.265.-.-
	H.140 cm	100 x 140 cm 80 x 140 cm	807.254.-.- 807.255.-.-
	H.120 cm	100 x 140 cm 80 x 140 cm	807.284.-.- 807.285.-.-
	H.140 cm	100 x 140 cm 80 x 140 cm	807.274.-.- 807.275.-.-
<b>En vis à vis terminal</b> Enfrentados terminal Face to face start unit	H.120 cm	100 x 140 cm 80 x 140 cm	807.284.-.- 807.285.-.-
	H.140 cm	100 x 140 cm 80 x 140 cm	807.274.-.- 807.275.-.-
	H.120 cm	100 x 140 cm 80 x 140 cm	807.284.-.- 807.285.-.-
	H.140 cm	100 x 140 cm 80 x 140 cm	807.274.-.- 807.275.-.-
<b>En vis à vis central</b> Enfrentados central Face to face add-on unit	H.120 cm	1400 x 70 + 100 cm 1400 x 70 + 80 cm	807.266.-.- 807.267.-.-
	H.140 cm	1400 x 70 + 100 cm 1400 x 70 + 80 cm	807.256.-.- 807.257.-.-
	5P:		
	H.120 cm H.140 cm	100 X 157 cm 100 X 157 cm	807.408.-.- 807.407.-.-
	7P:		
	H.120 cm H.140 cm	100 X 157 cm 100 X 157 cm	807.404.-.- 807.403.-.-

Margarite  
Margarita  
Cluster

## FINITIONS ACABADOS FINISHES

450	Blanc Blanco White	456	Gris Gris Grey	457	Hêtre Haya Beech	448	Graphite Grafito Graphite
458	Chêne Moyen Roble Maple	459	Poirier Peral Pear	492	Wengué Wengue Wengue	449	Argent Plata Silver
493	Acacia Clair Acacia Clara Light Acacia	494	Acacia Foncé Acacia Oscura Dark Acacia	025	Chêne Veiné Castaño Claro Oak	026	Chêne Grisé Castaño Oscuro Dark Oak



Cf. page 464  
Ver pagina 464  
See page 464

# FINITIONS | ACABADOS | FINISHES



CLOISONS / MAMPARA / SCREEN | PLATEAU / SOBRE / DESK TOP

Mélanges / Tissue Melamina / Tapizado Melamine / Upholstered	002	Blanc Blanco White	010	Gris Gris Grey	011	Hêtre Haya Beech	012	Chêne Moyen Roble Maple	013	Poirier Peral Pear	019	Wengué Wengue Wengue
	703	Acacia Clair Acacia Clara Light Acacia	704	Acacia Foncé Acacia Oscura Dark Acacia	004	Graphite Grafito Graphite	006	Argent Plata Silver	025	Chêne Veiné Castaño Claro Oak	026	Chêne Grisé Castaño Oscuro Dark Oak



Cf. page 464  
Ver pagina 464  
See page 464

# MODÈLES | VARIANTES | VERSIONS

MODÈLE / VARIANTES / VERSIONS	TYPE / TIPO / TYPE	DIMENSIONS / MEDIDAS / MEASUREMENTS	RÉFÉRENCE / REFERENCIA / CODE
	Modules: / Módulos de: / Moduls of:		25mm
	H.120 cm	100 x 70 cm 80 x 70 cm	807.214.-.- 807.215.-.-
<b>Individuel terminal</b> Individual terminal Single start unit	H.140 cm	100 x 70 cm 80 x 70 cm	807.204.-.- 807.205.-.-
	H.120 cm	100 x 70 cm 80 x 70 cm	807.234.-.- 807.235.-.-
	H.140 cm	100 x 70 cm 80 x 70 cm	807.224.-.- 807.225.-.-
	H.120 cm	100 x 70 cm 80 x 70 cm	807.234.-.- 807.235.-.-
<b>Individuel central</b> Individual central Single add-on unit	H.120 cm	100 x 140 cm 80 x 140 cm	807.264.-.- 807.265.-.-
	H.140 cm	100 x 140 cm 80 x 140 cm	807.254.-.- 807.255.-.-
	H.120 cm	100 x 140 cm 80 x 140 cm	807.284.-.- 807.285.-.-
	H.140 cm	100 x 140 cm 80 x 140 cm	807.274.-.- 807.275.-.-
<b>En vis à vis terminal</b> Enfrentados terminal Face to face start unit	H.120 cm	100 x 140 cm 80 x 140 cm	807.284.-.- 807.285.-.-
	H.140 cm	100 x 140 cm 80 x 140 cm	807.274.-.- 807.275.-.-
	H.120 cm	100 x 140 cm 80 x 140 cm	807.284.-.- 807.285.-.-
	H.140 cm	100 x 140 cm 80 x 140 cm	807.274.-.- 807.275.-.-
<b>En vis à vis central</b> Enfrentados central Face to face add-on unit	H.120 cm	1400 x 70 + 100 cm 1400 x 70 + 80 cm	807.266.-.- 807.267.-.-
	H.140 cm	1400 x 70 + 100 cm 1400 x 70 + 80 cm	807.256.-.- 807.257.-.-
	5P:		
	H.120 cm H.140 cm	100 X 157 cm 100 X 157 cm	807.408.-.- 807.407.-.-
	7P:		
	H.120 cm H.140 cm	100 X 157 cm 100 X 157 cm	807.404.-.- 807.403.-.-

## FINITIONS | ACABADOS | FINISHES

CLOISONS / MAMPARA / SCREEN | PLATEAU / SOBRE / DESK TOP

Méthacrylate transp. / Mélanges Met. Transparente / Melamina Clear methacrylate / Melamine	413	Blanc Blanco White	414	Gris Gris Grey	415	Hêtre Haya Beech	416	Chêne Moyen Roble Maple	417	Poirier Peral Pear	418	Wengué Wengue Wengue
	626	Acacia Clair Acacia Clara Light Acacia	627	Acacia Foncé Acacia Oscura Dark Acacia	408	Graphite Grafito Graphite	409	Argent Plata Silver	892	Chêne Veiné Castaño Claro Oak	893	Chêne Grisé Castaño Oscuro Dark Oak

# ROCK SYSTEMS

ROCK SYSTEMS est une gamme de cloisons modulaires qui permet de créer des espaces de travail dynamiques et confortables.

ROCK SYSTEMS es una serie de mamparas diseñadas para crear espacios de trabajo dinámicos. Con distintas formas y acabados se podrá aislar cualquier espacio manteniendo el estilo de las oficinas.

ROCK SYSTEMS is a furniture screen range. Designed with modular elements that can be combined to create an optimum, comfortable and visually appealing space.

## PLATEAU / SOBRE / DESK TOP

Agglomérer / Aglomerado / Chipboard 25 mm

## FINITION STRUCTURE / ACABADO ESTRUCTURA / FRAME FINISH

Aluminium  
Aluminio  
Aluminum

## FINITION CLOISONS / ACABADOS MAMPARA / SCREEN FINISHES

Mélamine / Melamina / Melamine  
Tissu / Tapizado / Upholstered  
Méthacrylate / Metacrilato / Methacrylate

## HAUTEUR / ALTURA / HEIGHT

Fixe:  
Fija: 101, 140, 178 cm  
Fixed:

ENSEMBLE  
DE CLOISONS  
DROITES

CONJUNTO  
DE MAMPARAS  
RECTAS

STRAIGHT  
SCREENS  
SET

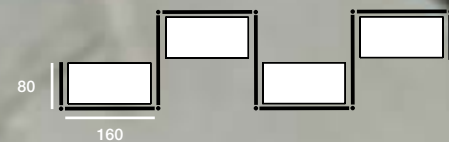



CLOISONS  
MONOPANNEAU

MAMPARAS RECTAS  
MONO PANEL

SINGLE PANEL  
STRAIGHT SCREENS

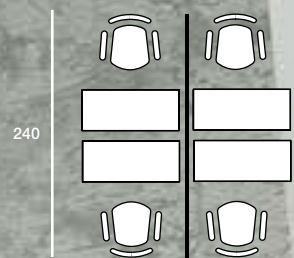

UNION CIRCULAIRE  
ENTRE 3  
CLOISONS

UNIÓN CIRCULAR  
ENTRE 3  
MAMPARAS

3 SCREENS  
SET



CLOISONS  
MULTI-PANNEAUX

MAMPARAS RECTAS  
MULTIPANEL

MULTIPANEL  
STRAIGHT SCREENS

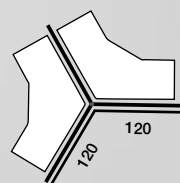

Unions entre 2, 3 ou 4 cloisons.  
Uniones de 2, 3 o 4 mamparas.  
Joining fittings of 2, 3 or 4 screens.

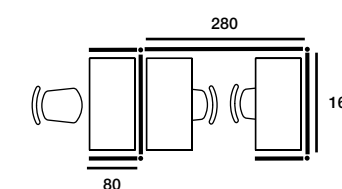

CLOISONS QUART  
DE CERCLE

MAMPARAS  
CURVADAS 90°

CURVED  
SCREENS

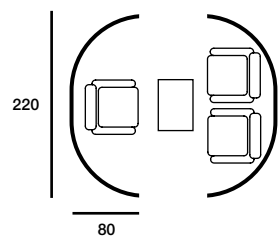

# NEKTA

Ligne de cloisons en méthacrylate transparent pour protéger et garantir la sécurité et la santé des gens sans perdre l'essence et le climat du travail collaboratif.

Línea de mamparas de metacrilato transparente para proteger y garantizar la seguridad y la salud de las personas sin perder la esencia y el clima del trabajo colaborativo.

Line of transparent methacrylate screens to protect and guarantee the safety and health preserving the nature and ambience of working together.

| INDIVIDUEL

| INDIVIDUAL

| SINGLE



## ÉCRAN / MAMPARA / SCREEN

Méthacrylate / Metacrilato / Methacrylate: 3-6 mm

## FINITION CLOISONS / ACABADOS MAMPARA / SCREEN FINISHES

Mét. Transparent / Met. Transparente / Clear methacrylate

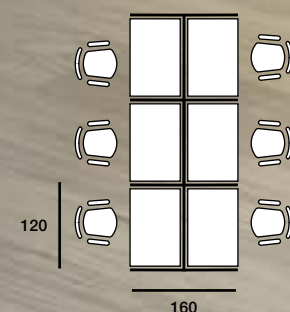



| ÉCRAN POUR CLOISONNETTE

| MAMPARA PARA PLAFÓN SEPARADOR

| PROTECTION FOR FRONT SCREEN

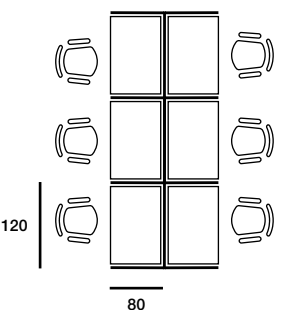

ÉCRAN AVEC  
FENTE

MAMPARAS CON  
ATENCIÓN AL  
CLIENTE

SCREENS FOR  
CUSTOMER  
SERVICE

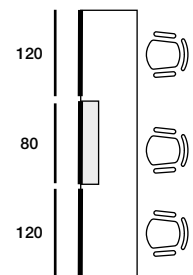



| POUR LUMINAIRES

| PARA LUMINARIAS

| FOR LIGHTING

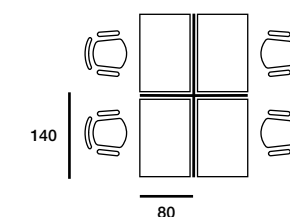



| ÉCRANS DE PROTECTION  
| SUSPENDUS

| MAMPARAS PROTECTORAS  
| COLGANTES

| HANGING PROTECTION  
| SCREENS

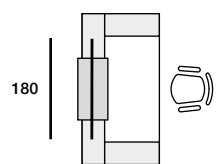





# MODÈLES | VARIANTES | VERSIONS

## SUR SUPPORT EN MÉTHACRYLATE / CON SOPORTE DE METACRILATO / WITH METHACRYLATE SUPPORT

MODÈLE / VARIANTES / VERSIONS	DIMENSIONS / MEDIDAS / MEASUREMENTS	RÉFÉRENCE / REFERENCIA / CODE
	120 x 67 x 0,3 cm 100 x 67 x 0,3 cm 80 x 67 x 0,3 cm	2 U. / 2 U. / 2 screens 727.021.411 727.023.411 727.025.411  4 U. / 4 U. / 4 screens 727.031.411 727.033.411 727.035.411
Écran de protection Mamparas protectoras Protection screens		
	120 x 67 x 0,3 cm 100 x 67 x 0,3 cm 80 x 67 x 0,3 cm	2 U. / 2 U. / 2 screens 727.022.411 727.024.411 727.026.411  4 U. / 4 U. / 4 screens 727.032.411 727.034.411 727.036.411
Écran avec fente Mamparas con atención al cliente Screens for customer service		

## SUR SUPPORT EN MÉTALLIQUE / CON SOPORTE METÁLICOS / WITH METAL SUPPORT

MODÈLE / VARIANTES / VERSIONS	DIMENSIONS / MEDIDAS / MEASUREMENTS	RÉFÉRENCE / REFERENCIA / CODE
	180 x 67 x 0,5 cm 160 x 67 x 0,5 cm 140 x 67 x 0,5 cm 120 x 67 x 0,5 cm 100 x 67 x 0,5 cm 80 x 67 x 0,5 cm	2 U. / 2 U. / 2 screens 725.112.411 725.114.411 725.116.411 725.118.411 725.120.411 725.122.411  4 U. / 4 U. / 4 screens 725.124.411 725.126.411 725.128.411 725.130.411 725.132.411 725.134.411
Écran de protection Mamparas protectoras Protection screens		
	180 x 67 x 0,5 cm 160 x 67 x 0,5 cm 140 x 67 x 0,5 cm 120 x 67 x 0,5 cm 100 x 67 x 0,5 cm 80 x 67 x 0,5 cm	2 U. / 2 U. / 2 screens 725.113.411 725.115.411 725.117.411 725.119.411 725.121.411 725.123.411  4 U. / 4 U. / 4 screens 725.125.411 725.127.411 725.129.411 725.131.411 725.133.411 725.135.411
Écran avec fente Mamparas con atención al cliente Screens for customer service		

## POUR CLOISONNETTES / PARA PLAFONES SEPARADORES / FOR SCREENS

MODÈLE / VARIANTES / VERSIONS	DIMENSIONS / MEDIDAS / MEASUREMENTS	RÉFÉRENCE / REFERENCIA / CODE
	178 x 32 x 0,6 cm 158x 32 x 0,6 cm 138 x 32 x 0,6 cm 118 x 32 x 0,6 cm 98 x 32 x 0,6 cm 78 x 32 x 0,6 cm	727.160.411 727.161.411 727.162.411 727.163.411 727.164.411 727.165.411  727.260.411 727.261.411 727.262.411 727.263.411 727.264.411 727.265.411  727.360.411 727.361.411 727.362.411 727.363.411 727.364.411 727.365.411
Écrans de protection frontaux Mamparas protectoras frontales Front protection screens		
	160 x 32 x 0,6 cm 140x 32 x 0,6 cm 120 x 32 x 0,6 cm 100 x 32 x 0,6 cm 80 x 32 x 0,6 cm 60 x 32 x 0,6 cm	727.170.411 727.171.411 727.172.411 727.173.411 727.174.411 727.175.411  727.270.411 727.271.411 727.272.411 727.273.411 727.274.411 727.275.411  727.370.411 727.371.411 727.372.411 727.373.411 727.374.411 727.375.411
Écrans de protection latérales Mamparas protectoras laterales Side protection screens		

## ÉCRANS DE PROTECTION / MAMPARAS PROTECTORAS / METHACRYLATE SCREEN

MODÈLE / VARIANTES / VERSIONS	DIMENSIONS / MEDIDAS / MEASUREMENTS	RÉFÉRENCE / REFERENCIA / CODE
	178 x 63,4 x 0,6 cm 158x 63,4 x 0,6 cm 138 x 63,4 x 0,6 cm 118 x 63,4 x 0,6 cm 98 x 63,4 x 0,6 cm 78 x 63,4 x 0,6 cm	726.175.411 726.176.411 726.177.411 726.178.411 726.179.411 726.180.411  726.275.411 726.276.411 726.277.411 726.278.411 726.279.411 726.280.411  726.375.411 726.376.411 726.377.411 726.378.411 726.379.411 726.380.411
Écrans de protection frontaux Mamparas protectoras frontales Front protection screens		

# FINITIONS | ACABADOS | FINISHES

## CLOISONS / MAMPARA / SCREEN | FINITION DES PINCES / ACABADOS PINZAS / BRACKET FINISHES

Mét. Transparent  
Met. Transparente  
Clear methacrylate

 Blanc  
Blanco  
White  
RAL 9016

 Argent  
Plata  
Silver  
RAL 9006

 Graphite  
Grafito  
Graphite  
RAL 7022

# MODÈLES | VARIANTES | VERSIONS

MODÈLE / VARIANTES / VERSIONS	TYPE / TIPO / TYPE	DIMENSIONS / MEDIDAS / MEASUREMENTS	RÉFÉRENCE / REFERENCIA / CODE
		158 x 57,5 x 0,6 cm 138 x 57,5 x 0,6 cm 118 x 57,5 x 0,6 cm	726.193.411 726.194.411 726.195.411

Écran de protection pour luminaires  
Mamparas protectoras para luminarias  
Protection screens for lighting

	Pour plafonds Para obra For concrete-steel ceiling	180 x 90 x 0,4 cm 160 x 90 x 0,4 cm 140 x 90 x 0,4 cm 120 x 90 x 0,4 cm 80 x 90 x 0,4 cm	724.002.411 724.004.411 724.006.411 724.008.411 724.012.411
---	--	--	---

	Pour faux plafonds Para techos técnicos For suspending ceiling	180 x 90 x 0,4 cm 160 x 90 x 0,4 cm 140 x 90 x 0,4 cm 120 x 90 x 0,4 cm 80 x 90 x 0,4 cm	724.102.411 724.104.411 724.106.411 724.108.411 724.112.411
---	--	--	---

Écrans de protection suspendus  
Mamparas protectoras colgantes  
Hanging protection screens



COLLECTIVITÉS  
COLECTIVIDADES  
MULTI-PURPOSE TABLES



**342 | CADÍ**



**348 | ESPACE**



**356 | NEXOS**



**362 | NET**

# Cadí

En combinant les dimensions disponibles, vous pourrez toujours meubler votre local pour petit qu'il soit.

Combinando las medidas disponibles siempre se puede encontrar un modelo que se adapte a un local, por pequeño que sea.

By combining different measurements, customized furniture ensembles can be created to suit rooms of any size.

## PLATEAU / SOBRE / DESK TOP

Mélamine / Melamina / Melamine  
Stratifié / Estratificado / Stratified 19 mm

Chant en ABS / Canto ABS / ABS edges

## STRUCTURE / ESTRUCTURA / FRAME

Acier:  
Acero: 30 x 30 x 1,5 mm  
Steel:



Périmétrale / Perimetral / Perimeter

## FINITION STRUCTURE / ACABADO ESTRUCTURA / FRAME FINISH

Peinture époxy  
Pintura epoxi  
Epoxy paint

## HAUTEUR / ALTURA / HEIGHT

72 cm

TABLE  
RECTANGULAIRE

MESA  
RECTANGULAR

RECTANGULAR  
DESK



TABLE  
TRAPÉZOÏDALE

MESA  
TRAPEZOIDAL

TRAPEZOIDAL  
DESK

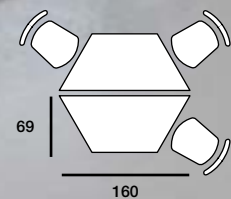
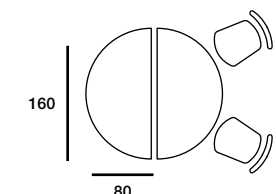

TABLE  
DEMI-RONDE



MESA  
SEMICIRCULAR

SEMICIRCULAR  
DESK

La table trapézoïdale permet plusieurs compositions.  
La mesa trapezoidal permite hacer múltiples composiciones.  
With the trapezoidal desk many shapes are available.



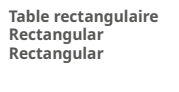













## MODÈLES | VARIANTES | VERSIONS

MODÈLE / VARIANTES / VERSIONS	DIMENSIONS / MEDIDAS / MEASUREMENTS	RÉFÉRENCE / REFERENCIA / CODE		
		■	■	■
 <p>Table rectangulaire Rectangular Rectangular</p>	180 x 80 cm	48.001.-..	48.011.-..	48.021.-..
	160 x 80 cm	48.002.-..	48.012.-..	48.022.-..
	140 x 80 cm	48.003.-..	48.013.-..	48.023.-..
	120 x 80 cm	48.004.-..	48.014.-..	48.024.-..
	80 x 80 cm	48.005.-..	48.015.-..	48.025.-..
 <p>Table rectangulaire Rectangular Rectangular</p>	160 x 70 cm	48.007.-..	48.017.-..	48.027.-..
	140 x 70 cm	48.008.-..	48.018.-..	48.028.-..
	120 x 70 cm	48.009.-..	48.019.-..	48.029.-..
	70 x 70 cm	48.006.-..	48.016.-..	48.026.-..
 <p>Table demi-ronde Semicircular Semicircular</p>	160 x 80 cm	48.040.-..	48.041.-..	48.042.-..
	140 x 70 cm	48.044.-..	48.045.-..	48.046.-..
 <p>Table trapézoïdale Trapezoidal Trapezoidal</p>	160 x 80 cm	48.050.-..	48.051.-..	48.052.-..
	140 x 70 cm	48.054.-..	48.055.-..	48.056.-..

## FINITIONS | ACABADOS | FINISHES

STRUCTURE / ESTRUCTURA / FRAME | PLATEAU / SOBRE / DESKTOP

 Noir Negro Black RAL 9005	 053 Blanc Blanco White	 054 Gris Gris Grey	 055 Hêtre Haya Beech	 061 Chêne Moyen Roble Maple
 Argent Plata Silver RAL 9006	 062 Poirier Peral Pear	 116 Wengué Wengue Wengue	 103 Acacia Clair Acacia Clara Light Acacia	 104 Acacia Foncé Acacia Oscura Dark Acacia
 Graphite Grafito Graphite RAL 7022	 007 Graphite Grafito Graphite	 272 Chêne Veiné Castaño Claro Oak	 273 Chêne Grisé Castaño Oscuro Dark Oak	

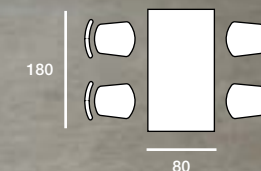

# espace

Espace s'adapte à toutes les ambiances de travail, recherchant l'élégance des formes et la simplicité des finitions.

Son caractère polyvalent permet de créer différents espaces. Un programme pour collectivités et bureaux sous un même nom.

Espace se adapta a los espacios de trabajo actuales buscando la simplicidad de formas y acabados. Programa de colectividades y oficina bajo un mismo nombre.

ESPACE fits in every office style. Simple looking with a round pole leg. Its versatility will allow to provide different environments. Useful for any kind of corner or room.

## PLATEAU / SOBRE / DESK TOP

Mélamine / Melamina / Melamine  
Stratifié / Estratificado / Stratified 25 mm

Chant en ABS / Canto ABS / ABS edges

## STRUCTURE / ESTRUCTURA / FRAME

Acier: Ø 55 x 1,5 mm  
Acero: Ø 55 x 1,5 mm  
Steel: Ø 55 x 1,5 mm



## FINITION STRUCTURE / ACABADO ESTRUCTURA / FRAME FINISH

Peinture époxy  
Pintura epoxi  
Epoxy paint

## HAUTEUR / ALTURA / HEIGHT

Fixe: 73 cm  
Fija: 73 cm  
Fixed: 73 cm

Réglable: 69,5 < 80,5 cm  
Regulable: 69,5 < 80,5 cm  
Adjustable: 69,5 < 80,5 cm

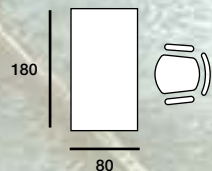

RÉGLABLE  
EN HAUTEUR

REGULABLE  
EN ALTURA

ADJUSTABLE  
HEIGHT



TABLE  
RECTANGULAIRE  
AVEC COINS  
ARRONDIS

MESA  
RECTANGULAR  
CON CANTOS  
REDONDEADOS

RECTANGULAR  
DESK WITH  
ROUNDED  
EDGES

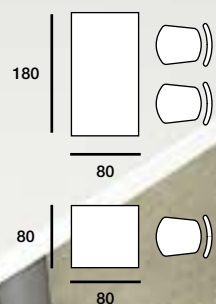



TABLE  
DEMI-RONDE

MESA SEMI-CIRCULAR  
CON MESA RECTA

SEMICIRCULAR  
DESK

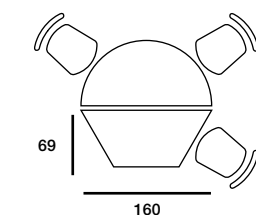

TABLE  
TRAPÉZOÏDALE +  
DEMI-RONDE

MESA  
TRAPEZOIDAL  
CON MESA  
SEMI-CIRCULAR

TRAPEZOIDAL  
DESK

La table trapézoïdale permet plusieurs compositions.  
La mesa trapezoidal permite hacer múltiples composiciones.  
With the trapezoidal desk many shapes are available.



# MODÈLES | VARIANTES | VERSIONS

## HAUTEUR FIXE / FIJAS / FIXED HEIGHT

MODÈLE / VARIANTES / VERSIONS	DIMENSIONS / MEDIDAS / MEASUREMENTS	RÉFÉRENCE / REFERENCIA / CODE	
	180 x 80 cm 160 x 80 cm 140 x 80 cm 120 x 80 cm 80 x 80 cm	Coins droits Cantos rectos Square edges	Coins arrondis Cantos redondeados Round edges
		371.301.---	371.501.---
		371.302.---	371.502.---
		371.303.---	371.503.---
		371.304.---	371.504.---
	371.305.---	371.505.---	
	180 x 70 cm 160 x 70 cm 140 x 70 cm 120 x 70 cm 80 x 70 cm	371.331.---	371.531.---
		371.332.---	371.532.---
		371.333.---	371.533.---
		371.334.---	371.534.---
		371.335.---	371.535.---
	180 x 60 cm 160 x 60 cm 140 x 60 cm 120 x 60 cm 80 x 60 cm	371.371.---	371.571.---
		371.372.---	371.572.---
		371.373.---	371.573.---
		371.374.---	371.574.---
371.375.---		371.575.---	

	160 x 80 cm	371.314.---	371.514.---
	140 x 70 cm	371.344.---	371.544.---
	120 x 60 cm	371.384.---	371.584.---

	160 x 69,3 cm	371.310.---	371.510.---
	140 x 60,6 cm	371.340.---	371.540.---
	120 x 52 cm	371.380.---	371.580.---

## RÉGLABLE EN HAUTEUR / REGULABLE EN ALTURA / ADJUSTABLE HEIGHT





MODÈLE / VARIANTES / VERSIONS	DIMENSIONS / MEDIDAS / MEASUREMENTS	RÉFÉRENCE / REFERENCIA / CODE	
	180 x 80 cm 160 x 80 cm 140 x 80 cm 120 x 80 cm 80 x 80 cm	Coins droits Cantos rectos Square edges	Coins arrondis Cantos redondeados Round edges
		371.401.---	371.601.---
		371.402.---	371.602.---
		371.403.---	371.603.---
		371.404.---	371.604.---
	371.405.---	371.605.---	
	180 x 70 cm 160 x 70 cm 140 x 70 cm 120 x 70 cm 80 x 70 cm	371.431.---	371.631.---
		371.432.---	371.632.---
		371.433.---	371.633.---
		371.434.---	371.634.---
		371.435.---	371.635.---
	180 x 60 cm 160 x 60 cm 140 x 60 cm 120 x 60 cm 80 x 60 cm	371.471.---	371.671.---
		371.472.---	371.672.---
		371.473.---	371.673.---
		371.474.---	371.674.---
371.475.---		371.675.---	

	160 x 80 cm	371.414.---	371.614.---
	140 x 70 cm	371.444.---	371.644.---
	120 x 60 cm	371.484.---	371.684.---

	160 x 69,3 cm	371.410.---	371.610.---
	140 x 60,6 cm	371.440.---	371.640.---
	120 x 52 cm	371.480.---	371.680.---

# FINITIONS | ACABADOS | FINISHES

## STRUCTURE / ESTRUCTURA / FRAME | PLATEAU / SOBRE / DESK TOP

	060 Blanc Blanco White	064 Gris Gris Grey	065 Hêtre Haya Beech	066 Chêne Moyen Roble Maple	067 Poirier Peral Pear
	068 Wengué Wengue Wengue	706 Acacia Clair Acacia Clara Light Acacia	707 Acacia Foncé Acacia Oscura Dark Acacia	020 Graphite Grafito Graphite	031 Chêne Veiné Castaño Claro Oak
	032 Chêne Grisé Castaño Oscuro Dark Oak				
	096 Blanc Blanco White	097 Gris Gris Grey	098 Hêtre Haya Beech	099 Chêne Moyen Roble Maple	100 Poirier Peral Pear
	101 Wengué Wengue Wengue	709 Acacia Clair Acacia Clara Light Acacia	710 Acacia Foncé Acacia Oscura Dark Acacia	017 Graphite Grafito Graphite	166 Chêne Veiné Castaño Claro Oak
	167 Chêne Grisé Castaño Oscuro Dark Oak				
	102 Blanc Blanco White	153 Gris Gris Grey	154 Hêtre Haya Beech	155 Chêne Moyen Roble Maple	156 Poirier Peral Pear
	158 Wengué Wengue Wengue	712 Acacia Clair Acacia Clara Light Acacia	713 Acacia Foncé Acacia Oscura Dark Acacia	165 Graphite Grafito Graphite	189 Chêne Veiné Castaño Claro Oak
	193 Chêne Grisé Castaño Oscuro Dark Oak				
	163 Blanc Blanco White	180 Gris Gris Grey	181 Hêtre Haya Beech	182 Chêne Moyen Roble Maple	183 Poirier Peral Pear
	184 Wengué Wengue Wengue	715 Acacia Clair Acacia Clara Light Acacia	716 Acacia Foncé Acacia Oscura Dark Acacia	113 Graphite Grafito Graphite	206 Chêne Veiné Castaño Claro Oak
	208 Chêne Grisé Castaño Oscuro Dark Oak				

# Nexos

Les sommets et les matériaux naturels qui composent la table NEXOS créent des environnements légers, organiques et agréables. Un design polyvalent idéal pour habiter des espaces collectifs tels que des cantines, des espaces de repos et des zones de travail informelles.

Los vértices y los materiales naturales que conforman la mesa NEXOS crean ambientes ligeros, orgánicos y placenteros. Un diseño versátil y polivalente perfecto para habitar espacios colectivos como cantinas, espacios de descanso y zonas de trabajo informal.

The natural materials of the Nexos table create bright, organic, and pleasant environments. A versatile design perfect for multi-purpose spaces such as canteens, rest spaces and informal work areas.

## PLATEAU / SOBRE / DESKTOP

Mélamine / Melamina / Melamine: 25 mm

Chant en ABS / Canto ABS / ABS edges

## STRUCTURE / ESTRUCTURA / FRAME

Bois: 45 x 45 mm - 25 x 25 mm  
Madera: 45 x 45 mm - 25 x 25 mm  
Wood: 45 x 45 mm - 25 x 25 mm



Bois: 45 x 30 mm  
Madera: 45 x 30 mm  
Wood: 45 x 30 mm



## FINITION STRUCTURE / ACABADO ESTRUCTURA / FRAME FINISH

Bois vernis  
Madera barnizada  
Wood veneer

## HAUTEUR / ALTURA / HEIGHT

76 mm

75 mm

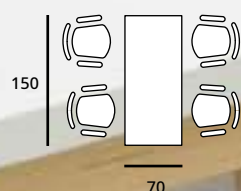
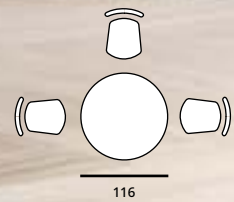



TABLE  
RONDE

MESA  
REDONDA

ROUND  
TABLE









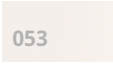
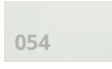

# MODÈLES | VARIANTES | VERSIONS

MODÈLE / VARIANTES / VERSIONS	TYPE / TIPO / TYPE	DIMENSIONS / MEDIDAS / MEASUREMENTS		RÉFÉRENCE / REFERENCIA / CODE
	Rectangulaire / Rectangular / Rectangular	150 x 70 cm 130 x 70 cm 110 x 70 cm 70 x 70 cm		171.502.-.- 171.504.-.- 171.506.-.- 171.508.-.-
Bureau individuel Mesa individual Individual desks				
	Ronde / Redondo / Round	H. 75 cm	Ø130 cm Ø116 cm Ø100 cm Ø75 cm	171.510.-.- 171.512.-.- 171.514.-.- 171.516.-.-
Bureau individuel Mesa individual Individual desks				

# FINITIONS | ACABADOS | FINISHES

STRUCTURE / ESTRUCTURA / FRAME | PLATEAU / SOBRE / DESKTOP

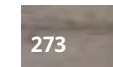
	Hêtre Haya Beech veneer		053 Blanc Blanco White		054 Gris Gris Grey		055 Hêtre Haya Beech		061 Chêne Moyen Roble Maple
	062 Poirier Peral Pear		116 Wengué Wengue Wengue		103 Acacia Clair Acacia Clara Light Acacia		104 Acacia Foncé Acacia Oscura Dark Acacia		
	007 Graphite Gráfico Graphite		272 Chêne Veiné Castaño Claro Oak		273 Chêne Gris Castaño Oscuro Dark Oak				

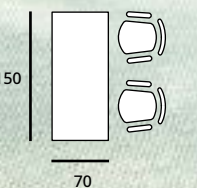

# Net

Table polyvalente qui grâce à ses formes et à sa mobilité permet la création de multiples combinaisons.

Mesa polivalente de múltiples posibilidades, gracias a su movilidad y variedad de formas.

Multipurpose table thanks to its great variety of shapes.

TABLE  
RECTANGULAIRE

MESA  
RECTANGULAR

RECTANGULAR  
DESK



## PLATEAU / SOBRE / DESK TOP

Mélamine / Melamina / Melamine: 25 mm / 30 mm  
Stratifié / Estratificado / Stratified:

Chant en ABS / Canto ABS / ABS edges

## STRUCTURE / ESTRUCTURA / FRAME

Aluminium  
Aluminio  
Aluminium



## FINITION STRUCTURE / ACABADO ESTRUCTURA / FRAME FINISH

Peinture époxy  
Pintura epoxi  
Epoxy paint

## HAUTEUR / ALTURA / HEIGHT

74 cm

## OPTION / OPCIÓN / OPTION

Voile de fond / Faldón / Modesty panel

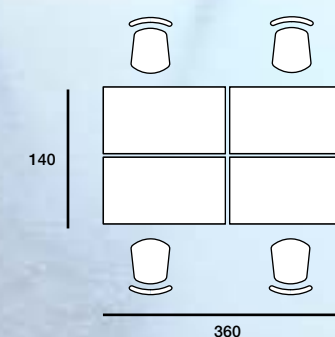



Elle peut facilement se ranger grâce à son plateau rabattable.  
Se puede almacenar sin ocupar mucho espacio gracias a su sobre abatible.  
Can be stored in a corner thanks to its foldable top.

La table avec quart de rond intégré nous permet créer plusieurs compositions.  
La mesa con ángulo permite hacer varias composiciones.  
Desk with angle allow multiple configurations.

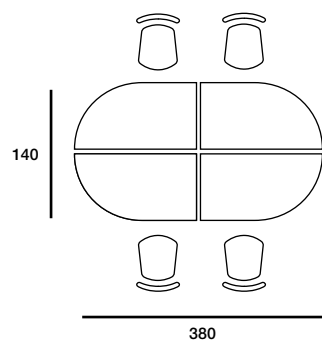

PLATEAU  
AVEC ANGLE

MESA  
CON ÁNGULO

DESK  
WITH ANGLE



TABLE  
DEMI-RONDE

MESA  
SEMICIRCULAR



SEMICIRCULAR  
DESK

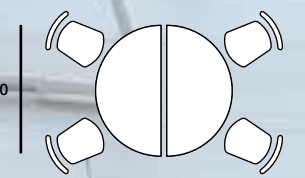

Roulettes équipées avec freins.  
Las mesas disponen de ruedas con freno.  
Wheels have brakes.





## MODÈLES | VARIANTES | VERSIONS

MODÈLE / VARIANTES / VERSIONS	TYPE / TIPO / TYPE	DIMENSIONS / MEDIDAS / MEASUREMENTS	RÉFÉRENCE / REFERENCIA / CODE
	Démontées / Desmontadas / Disassembled	180 x 70 cm 150 x 70 cm 120 x 70 cm	551.002... 551.005... 551.008...
	Semi montées / Semi montadas / Semi-assembled	180 x 70 cm 150 x 70 cm 120 x 70 cm	551.202... 551.205... 551.208...
<b>Table rectangulaire</b> Rectangular Rectangular			
À droite / Derecha / Right      À gauche / Izquierda / Left			
	Démontées / Desmontadas / Disassembled	190 x 70 cm	551.020...      551.021...
	Semi montées / Semi montadas / Semi-assembled	190 x 70 cm	551.220...      551.221...
<b>Table avec angle</b> Mesa con ángulo Desk with angle			
	Démontées / Desmontadas / Disassembled	180 x 90 cm	551.030...
	Semi montées / Semi montadas / Semi-assembled	180 x 90 cm	551.230...
<b>Table demi-ronde</b> Semicircular Semicircular			

## FINITIONS | ACABADOS | FINISHES



STRUCTURE / ESTRUCTURA / FRAME | PLATEAU / SOBRE / DESK TOP

	074	Blanc Blanco White	069	Gris Gris Grey	020	Graphite Grafito Graphite	070	Hêtre Haya Beech	071	Chêne Moyen Roble Maple
	072	Poirier Peral Pear	073	Wengué Wengue Wengue	730	Acacia Clair Acacia Clara Light Acacia	731	Acacia Foncé Acacia Oscura Dark Acacia	041	Chêne Veiné Castaño Claro Oak
	042	Chêne Grisé Castaño Oscuro Dark Oak								
	082	Blanc Blanco White	083	Gris Gris Grey	321	Graphite Grafito Graphite	084	Hêtre Haya Beech	085	Chêne Moyen Roble Maple
	086	Poirier Peral Pear	087	Wengué Wengue Wengue	733	Acacia Clair Acacia Clara Light Acacia	734	Acacia Foncé Acacia Oscura Dark Acacia	121	Chêne Veiné Castaño Claro Oak
	122	Chêne Grisé Castaño Oscuro Dark Oak								

## COMPLÉMENTS | COMPLEMENTOS | COMPLEMENTS

MODÈLE / VARIANTES / VERSIONS	DIMENSIONS / MEDIDAS / MEASUREMENTS	RÉFÉRENCE / REFERENCIA / CODE	
	Mélamine / Melamina / Melamine	180 cm 150 cm 120 cm / 190 cm	1.551.402.051      1.551.402.053      1.551.402.007 1.551.405.051      1.551.405.053      1.551.405.007 1.551.408.051      1.551.408.053      1.551.408.007
<b>Voiles de fond</b> Faldones Modesty panels			

## FINITIONS | ACABADOS | FINISHES

	Argent Plata Silver		Blanc Blanco White		Graphite Grafito Graphite
---	---------------------------	---	--------------------------	---	---------------------------------

## COMPLÉMENTS | COMPLEMENTOS | COMPLEMENTS

MODÈLE / VARIANTES / VERSIONS	TYPE / TIPO / TYPE	RÉFÉRENCE / REFERENCIA / CODE
	2 unités incluses / Incluye dos unidades / 2 units included	1.551.300.000
<b>Pièce union tables</b> Piezas unión mesas Linking bracket		

## EXEMPLES | EJEMPLOS | EXAMPLES

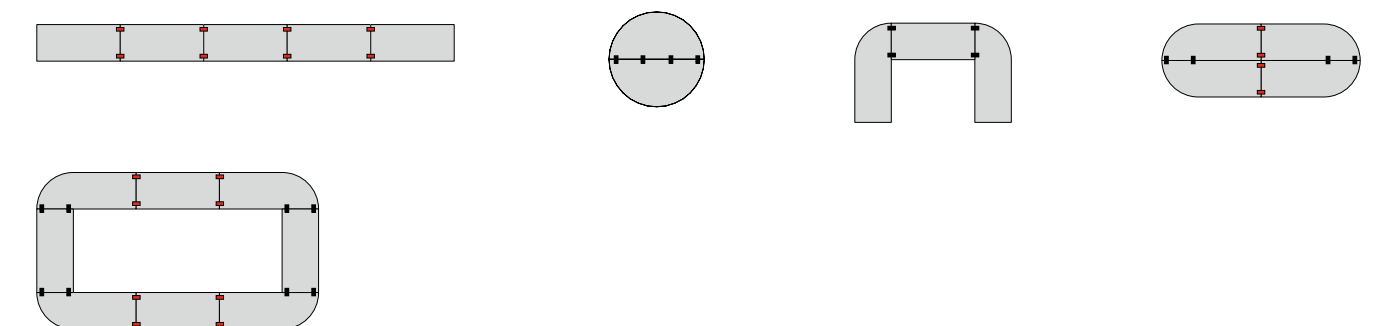

ACCUEIL  
RECEPCIÓN  
RECEPTION



**374** | DELTA



**388** | ROCK RECEPTION

# Delta

Le banque d'accueil DELTA se démarque par ses lignes droites, de design atemporel. Elle propose 2 gammes: La Basique, plus simple et uniquement modulable en horizontal; et la gamme PLUS, avec illumination LED, formes variées et rehausse optionnelle.

El mostrador DELTA destaca por sus líneas rectas, un minimalismo que lo convierte en un diseño atemporal. Ofrece dos gamas: Basic, más sencilla y con crecimiento horizontal; y la gama Plus, con iluminación LED y altillo opcional.

DELTA counter has a timeless design thanks to its straight lines. Basic range is simple and with horizontal expansion. Plus range has LED lights and an optional upper counter top.

## MODULE / MÓDULO / LOW STORAGE

Mélamine / Melamina / Melamine: 25 mm

Chant en ABS / Canto ABS / ABS edges

## FINITION STRUCTURE / ACABADO ESTRUCTURA / FRAME FINISH

Mélamine  
Melamina  
Melamine

## HAUTEUR / ALTURA / HEIGHT

Fixe:  
Fija: 73, 110 cm  
Fixed:

## OPTION / OPCIÓN / OPTION

Rehausse / Altillo / Upper counter top  
Socle avec éclairage / Zócalo con luz Led / Socle with Led light  
Goulotte / Bandeja electrificación / Cable tray  
Support écran / Soporte pantalla / Monitor holder

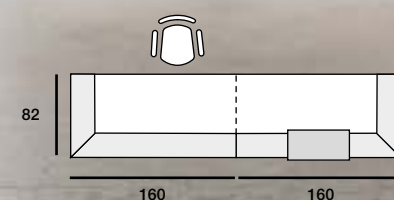

| DELTA PLUS

| DELTA PLUS

| DELTA PLUS

DELTA PLUS  
AVEC MODULE  
BUREAU D'ACCUEIL

DELTA PLUS  
CON ATENCIÓN  
AL CLIENTE

DELTA PLUS  
WITH DESK  
HEIGHT COUNTER

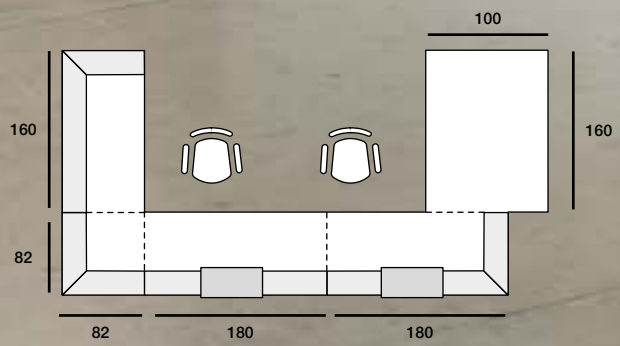

DELTA PLUS  
AVEC SUPPORT  
ÉCRAN

DELTA PLUS  
CON SOPORTE  
PARA PANTALLAS

DELTA PLUS  
WITH MONITOR  
HOLDER

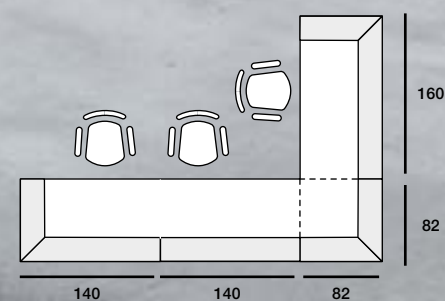

Deux options pour mettre en place l'écran.  
Dos opciones distintas para colocar el monitor.  
Two different ways to fix the computer screen.



DELTA  
BASIC

DELTA  
BASIC

DELTA  
BASIC

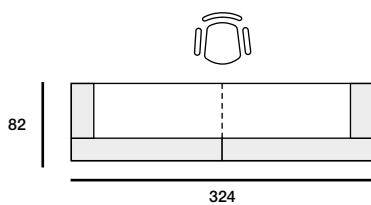



# MODÈLES | VARIANTES | VERSIONS

## DELTA PLUS - AVEC ÉCLAIRAGE / CON LUZ / WITH LIGHT

MODÈLE / VARIANTES / VERSIONS	TYPE / TIPO / TYPE	DIMENSIONS / MEDIDAS / MEASUREMENTS	RÉFÉRENCE / REFERENCIA / CODE
 Terminal Terminal Start	H. 110 cm	Droite / Derecha / Right 182,2 x 82,1 cm 162,2 x 82,1 cm 142,2 x 82,1 cm 102,2 x 82,1 cm 82,2 x 82,1 cm (90°)	Option écran Opción pantalla PC screen option 622.212... 622.412... 622.216... 622.416... 622.220... 622.420... 622.227... 622.427... 622.224...
	H. 110 cm	Gauche / Izquierda / Left 182,2 x 82,1 cm 162,2 x 82,1 cm 142,2 x 82,1 cm 102,2 x 82,1 cm 82,2 x 82,1 cm (90°)	622.214... 622.414... 622.218... 622.418... 622.222... 622.422... 622.228... 622.428... 622.226...
 Central Central Add-on	H. 110 cm	B	180 x 82,1 cm 160 x 82,1 cm 140 x 82,1 cm 622.230... 622.430... 622.232... 622.432... 622.234... 622.434...
		B2	Droite / Derecha / Right 82,2 x 82,1 cm 622.236...
		B1	Gauche / Izquierda / Left 82,2 x 82,1 cm 622.237...

## DELTA PLUS - SANS ÉCLAIRAGE / SIN LUZ / WITHOUT LIGHT

 Terminal Terminal Start	H. 110 cm	Droite / Derecha / Right 182,2 x 82,1 cm 162,2 x 82,1 cm 142,2 x 82,1 cm 102,2 x 82,1 cm 82,2 x 82,1 cm (90°)	Option écran Opción pantalla PC screen option 622.112... 622.312... 622.116... 622.316... 622.120... 622.320... 622.127... 622.327... 622.124...
	H. 110 cm	Gauche / Izquierda / Left 182,2 x 82,1 cm 162,2 x 82,1 cm 142,2 x 82,1 cm 102,2 x 82,1 cm 82,2 x 82,1 cm (90°)	622.114... 622.314... 622.118... 622.318... 622.122... 622.322... 622.128... 622.328... 622.126...
 Central Central Add-on	H. 110 cm	B	180 x 82,1 cm 160 x 82,1 cm 140 x 82,1 cm 622.130... 622.330... 622.132... 622.332... 622.134... 622.334...
		B2	Droite / Derecha / Right 82,2 x 82,1 cm (90°) 622.136...
		B1	Gauche / Izquierda / Left 82,2 x 82,1 cm (90°) 622.137...

## EXEMPLE | EJEMPLOS | EXAMPLES

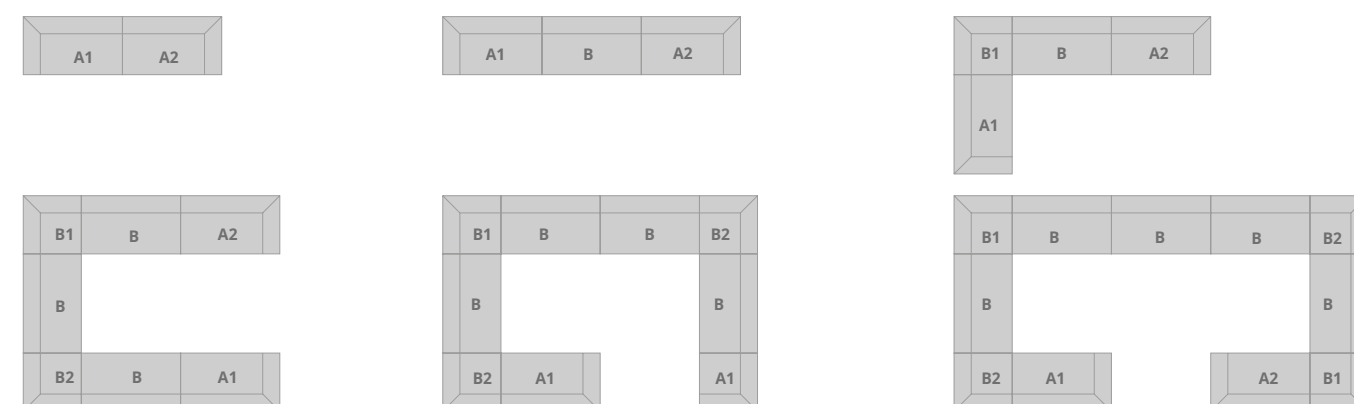



# MODÈLES | VARIANTES | VERSIONS

## DELTA PLUS - AVEC ÉCLAIRAGE / CON LUZ / WITH LIGHT

MODÈLE / VARIANTES / VERSIONS	TYPE / TIPO / TYPE	DIMENSIONS / MEDIDAS / MEASUREMENTS	RÉFÉRENCE / REFERENCIA / CODE
 Terminal Terminal Start	H. 73 cm	Droite / Derecha / Right 180 x 100 cm 160 x 100 cm 140 x 100 cm 100 x 100 cm 622.240... 622.244... 622.248... 622.251...	
	H. 73 cm	Gauche / Izquierda / Left 180 x 100 cm 160 x 100 cm 140 x 100 cm 100 x 100 cm 622.242... 622.246... 622.250... 622.252...	
 Central Central Add-on	H. 73 cm	B	180 x 100 cm 160 x 100 cm 140 x 100 cm 622.260... 622.262... 622.264...
		B2	Droite / Derecha / Right 82,2 x 82,1 cm (90°) 622.266...
		B1	Gauche / Izquierda / Left 82,2 x 82,1 cm (90°) 622.267...

## DELTA PLUS - SANS ÉCLAIRAGE / SIN LUZ / WITHOUT LIGHT

 Terminal Terminal Start	H. 73 cm	Droite / Derecha / Right 180 x 100 cm 160 x 100 cm 140 x 100 cm 100 x 100 cm 622.140... 622.144... 622.148... 622.151...	
	H. 73 cm	Gauche / Izquierda / Left 180 x 100 cm 160 x 100 cm 140 x 100 cm 100 x 100 cm 622.142... 622.146... 622.150... 622.152...	
 Central Central Add-on	H. 73 cm	B	180 x 100 cm 160 x 100 cm 140 x 100 cm 622.160... 622.162... 622.164...
		B2	Droite / Derecha / Right 82,2 x 82,1 cm (90°) 622.166...
		B1	Gauche / Izquierda / Left 82,2 x 82,1 cm (90°) 622.167...

## FINITIONS | ACABADOS | FINISHES

204	Graphite Grafito Graphite	051	Argent Plata Silver	053	Blanc Blanco White	197	Gris Gris Grey	198	Hêtre Haya Beech
199	Chêne Moyen Roble Maple	200	Poirier Peral Pear	202	Wengué Wengue Wengue	103	Acacia Clair Acacia Clara Light Acacia	104	Acacia Foncé Acacia Oscura Dark Acacia
209	Chêne Veiné Castaño Claro Oak	235	Chêne Grisé Castaño Oscuro Dark Oak						



## MODÈLES | VARIANTES | VERSIONS

### DELTA PLUS - AVEC ÉCLAIRAGE / CON LUZ / WITH LIGHT

MODÈLE / VARIANTES / VERSIONS	TYPE / TIPO / TYPE	DIMENSIONS / MEDIDAS / MEASUREMENTS	RÉFÉRENCE / REFERENCIA / CODE
	H. 110 cm	184,4 x 82,1 cm 164,4 x 82,1 cm 144,4 x 82,1 cm	Option écran Opción pantalla PC screen option  622.202.-.- 622.402.-.- 622.204.-.- 622.404.-.- 622.206.-.- 622.406.-.-
Individuel Individual Individual			

### DELTA PLUS - SANS ÉCLAIRAGE / SIN LUZ / WITHOUT LIGHT

MODÈLE / VARIANTES / VERSIONS	TYPE / TIPO / TYPE	DIMENSIONS / MEDIDAS / MEASUREMENTS	RÉFÉRENCE / REFERENCIA / CODE
	H. 110 cm	184,4 x 82,1 cm 164,4 x 82,1 cm 144,4 x 82,1 cm	Option écran Opción pantalla PC screen option  622.102.-.- 622.302.-.- 622.104.-.- 622.304.-.- 622.106.-.- 622.306.-.-
Individuel Individual Individual			

## COMPLÉMENTS | COMPLEMENTOS | COMPLEMENTS

MODÈLE / VARIANTES / VERSIONS	DIMENSIONS / MEDIDAS / MEASUREMENTS	RÉFÉRENCE / REFERENCIA / CODE
	80 x 36 cm	Option éclairage Con luz With light 622.170.-.- * 624.170.-.- *
Rehausse Atillo Upper counter top	120 x 36 cm	622.172.-.- * 624.172.-.- *

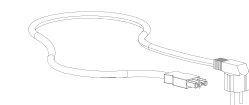

Éclairage  
Latiguillo  
Light

ES	DE	FR	US	UK
446.991.000			446.992.000	446.995.000

## FINITIONS | ACABADOS | FINISHES

<b>204</b> Graphite Grafito Graphite	<b>051</b> Argent Plata Silver	<b>053</b> Blanc Blanco White	<b>197</b> Gris Gris Grey	<b>198</b> Hêtre Haya Beech
<b>199</b> Chêne Moyen Roble Maple	<b>200</b> Poirier Peral Pear	<b>202</b> Wengué Wengue Wengue	<b>103</b> Acacia Clair Acacia Clara Light Acacia	<b>104</b> Acacia Foncé Acacia Oscura Dark Acacia
<b>209</b> Chêne Veiné Castaño Claro Oak	<b>235</b> Chêne Grisé Castaño Oscuro Dark Oak	* Cf. page 464 Ver pagina 464 See page 464		

## MODÈLES | VARIANTES | VERSIONS

### DELTA BASIC

MODÈLE / VARIANTES / VERSIONS	TYPE / TIPO / TYPE	DIMENSIONS / MEDIDAS / MEASUREMENTS	RÉFÉRENCE / REFERENCIA / CODE
	H. 110 cm	184,4 x 82,1 cm 164,4 x 82,1 cm 144,4 x 82,1 cm	621.102.-.- 621.104.-.- 621.106.-.-
Terminal Terminal Individual			

MODÈLE / VARIANTES / VERSIONS	TYPE / TIPO / TYPE	DIMENSIONS / MEDIDAS / MEASUREMENTS	RÉFÉRENCE / REFERENCIA / CODE
	H. 110 cm	364,4 x 82,1 cm 324,4 x 82,1 cm 284,4 x 82,1 cm	621.112.-.- 621.114.-.- 621.116.-.-
Double Doble Double			

MODÈLE / VARIANTES / VERSIONS	TYPE / TIPO / TYPE	DIMENSIONS / MEDIDAS / MEASUREMENTS	RÉFÉRENCE / REFERENCIA / CODE
	H. 110 cm	C 180 x 82,1 cm 160 x 82,1 cm 140 x 82,1 cm	621.122.-.- 621.124.-.- 621.126.-.-
Central Central Add-on			

## EXEMPLE | EJEMPLOS | EXAMPLES

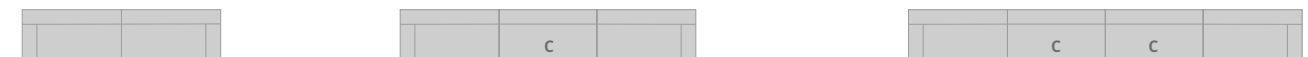

## FINITIONS | ACABADOS | FINISHES

<b>204</b> Graphite Grafito Graphite	<b>051</b> Argent Plata Silver	<b>053</b> Blanc Blanco White	<b>197</b> Gris Gris Grey	<b>198</b> Hêtre Haya Beech
<b>199</b> Chêne Moyen Roble Maple	<b>200</b> Poirier Peral Pear	<b>202</b> Wengué Wengue Wengue	<b>103</b> Acacia Clair Acacia Clara Light Acacia	<b>104</b> Acacia Foncé Acacia Oscura Dark Acacia
<b>209</b> Chêne Veiné Castaño Claro Oak	<b>235</b> Chêne Grisé Castaño Oscuro Dark Oak			

## | COMPLÉMENTS | COMPLEMENTOS | COMPLEMENTS

MODÈLE / VARIANTES / VERSIONS	DIMENSIONS / MEDIDAS / MEASUREMENTS	RÉFÉRENCE / REFERENCIA / CODE
-------------------------------	-------------------------------------	-------------------------------



Goulotte pour banquettes d'accueil  
Bandeja de electrificación  
Cable tray

159 x 11,4 x 9,8 cm  
139 x 11,4 x 9,8 cm  
119 x 11,4 x 9,8 cm  
59 x 11,4 x 9,8 cm

RAL 9006	RAL 9016	RAL 7022
1.566.002.111	1.566.002.108	1.566.002.107
1.566.003.111	1.566.003.108	1.566.003.107
1.566.004.111	1.566.004.108	1.566.004.107
1.566.008.111	1.566.008.108	1.566.008.107

## | FINITIONS | ACABADOS | FINISHES

STRUCTURE / ESTRUCTURA / FRAME

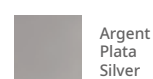

RAL 9006

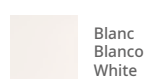

RAL 9016

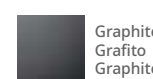

RAL 7022

Argent  
Plata  
Silver

Blanc  
Blanco  
White

Graphite  
Grafito  
Graphite

## | COMPLÉMENTS | COMPLEMENTOS | COMPLEMENTS

MODÈLE / VARIANTES / VERSIONS	RÉFÉRENCE / REFERENCIA / CODE
-------------------------------	-------------------------------



Support écran  
Soporte pantalla  
Monitor holder

626.001.124

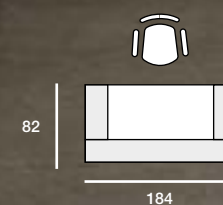

# ROCK RECEPTION

ROCK RECEPTION est une série de banques d'accueil modulaires qui offre de multiples combinaisons pour obtenir un ensemble visuellement attrayant. Vous pouvez créer des banques d'accueil sur mesure, pour refléter la personnalité de votre entreprise.

ROCK RECEPTION es un completo programa de mostradores modulares que se combinan a voluntad para diseñar un conjunto optimizado, estético y comfortable. Se pueden crear recepciones a medida.

ROCK RECEPTION is a complete range of modular reception counters designed with elements that can be combined to create an optimum, comfortable and visually appealing reception. It is important to customize a reception area to reflect the unique personality of a company or organisation.

## MODULE / MÓDULO / MODULE

Mélamine / Melamina / Melamine: 25 mm

Verre trempé / Cristal securizado / Tempered beveled glass: 13 mm

Chant en ABS / Canto ABS / ABS edges

## FINITION STRUCTURE / ACABADO ESTRUCTURA / FRAME FINISH

Aluminium  
Aluminio  
Aluminum

## FINITION CLOISONS / ACABADOS MAMPARA / SCREEN FINISHES

Mélamine / Melamina / Melamine

## HAUTEUR / ALTURA / HEIGHT

Fixe: 106,9, 73 cm Réglable: 112,35 > 118,75 cm  
Fija: Regulable:  
Fixed: Adjustable:

BANQUES  
D'ACCUEIL  
MULTI-PANNEAUX

MOSTRADORES  
MULTIPANEL

MULTI PANEL  
COUNTER

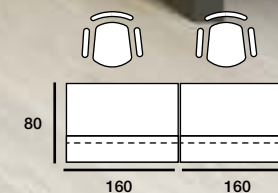

| BUREAU PMR

| MESA ATENCIÓN  
AL CLIENTE

| HANDICAPPED  
DESK



Disponibile en angle 45° ou droit.  
Disponibile en ángulo o mesa recta.  
Straight or curved shape available.

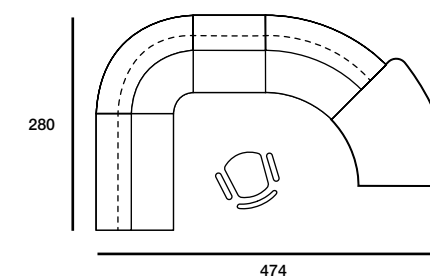
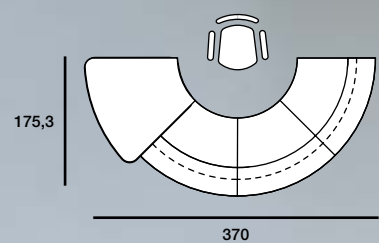

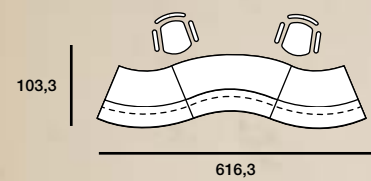

REHAUSSE FIXE  
OU RÉGLABLE  
EN HAUTEUR

MOSTRADOR FIJO  
O REGULABLE  
EN ALTURA

FIXED OR HEIGHT  
ADJUSTABLE  
COUNTER

BANQUES D'ACCUEIL  
UN SEUL PANNEAU

MOSTRADORES  
UNIPANEL

SINGLE  
PANEL COUNTER

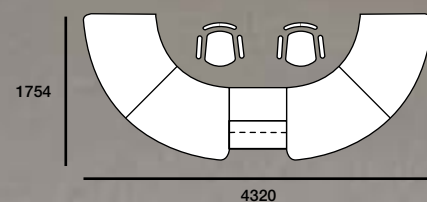

## MODÈLES | VARIANTES | VERSIONS

UN SEUL PANNEAU - ROCK 3 / UNIPANEL - ROCK 3 / SINGLE PANEL - ROCK 3

MODÈLE / VARIANTES / VERSIONS	TYPE / TIPO / TYPE	DIMENSIONS / MEDIDAS / MEASUREMENTS	RÉFÉRENCE / REFERENCIA / CODE
	Prof./Depth 60 cm	200,6 x 100 x 106,9 cm	433.144.-.-
	Prof./Depth 60 cm	318,8 x 99,4 x 106,9 cm	433.145.-.-
	Prof./Depth 60 cm	278,8 x 120 x 106,9 cm	433.146.-.-
	Prof./Depth 60 cm	299,4 x 194,7 x 106,9 cm	433.147.-.-
	Prof./Depth 60 cm	299,4 x 175,5 x 106,9 cm	433.148.-.-
	Prof./Depth 60 cm	296,4 x 175,5 x 106,9 cm	433.149.-.-
	Prof./Depth 60 cm	296,4 x 195,2 x 106,9 cm	433.150.-.-
	Prof./Depth 60 cm	350,7 x 175,5 x 106,9 cm	433.151.-.-

## MODÈLES | VARIANTES | VERSIONS

MODÈLE / VARIANTES / VERSIONS	TYPE / TIPO / TYPE	DIMENSIONS / MEDIDAS / MEASUREMENTS	RÉFÉRENCE / REFERENCIA / CODE
	Prof./Depth 60 cm	375,4 x 103,3 x 106,9 cm	433.154.-.-
	Prof./Depth 60 cm	198,8 x 99,4 x 106,9 cm	433.141.-.-
	Prof./Depth 60 cm	198,8 x 169,6 x 106,9 cm	433.140.-.-
	Prof./Depth 60 cm	616,3 x 103,3 x 106,9 cm	433.155.-.-

## FINITIONS | ACABADOS | FINISHES

REHAUSSE / SOBRE / COUNTER TOP | LATÉRAUX / LATERAL / PANEL LEG

Rehausse en mélamine Sobre mostrador en melamina Melamine counter top	053	Blanc Blanco White	054	Gris Gris Grey	055	Hêtre Haya Beech	061	Chêne Moyen Roble Maple	062	Poirier Peral Pear	063	Wengué Wengue
	103	Acacia Clair Acacia Clara Light Acacia	104	Acacia Foncé Acacia Oscura Dark Acacia	007	Graphite Grafito Graphite						
Rehausse en verre Sobre mostrador en vidrio Glass counter top	453	Blanc Blanco White	454	Gris Gris Grey	455	Hêtre Haya Beech	461	Chêne Moyen Roble Maple	462	Poirier Peral Pear	463	Wengué Wengue
	793	Acacia Clair Acacia Clara Light Acacia	794	Acacia Foncé Acacia Oscura Dark Acacia	487	Graphite Grafito Graphite						

# MODÈLES | VARIANTES | VERSIONS

## MULTI PANNEAUX - ROCK 3 / MULTIPANEL - ROCK 3 / MULTI PANEL - ROCK 3

MODÈLE / VARIANTES / VERSIONS	TYPE / TIPO / TYPE	DIMENSIONS / MEDIDAS / MEASUREMENTS	RÉFÉRENCE / REFERENCIA / CODE
	Prof./Depth 60 cm	200,6 x 100 x 106,9 cm	433.344.-.-
	Prof./Depth 60 cm	318,8 x 99,4 x 106,9 cm	433.345.-.-
	Prof./Depth 60 cm	278,8 x 120 x 106,9 cm	433.346.-.-
	Prof./Depth 60 cm	299,4 x 194,7 x 106,9 cm	433.347.-.-
	Prof./Depth 60 cm	299,4 x 175,5 x 106,9 cm	433.348.-.-
	Prof./Depth 60 cm	296,4 x 175,5 x 106,9 cm	433.349.-.-
	Prof./Depth 60 cm	296,4 x 195,2 x 106,9 cm	433.350.-.-
	Prof./Depth 60 cm	350,7 x 175,5 x 106,9 cm	433.351.-.-

MODÈLE / VARIANTES / VERSIONS	TYPE / TIPO / TYPE	DIMENSIONS / MEDIDAS / MEASUREMENTS	RÉFÉRENCE / REFERENCIA / CODE
	Prof./Depth 60 cm	375,4 x 103,3 x 106,9 cm	433.354.-.-
	Prof./Depth 60 cm	198,8 x 99,4 x 106,9 cm	433.341.-.-
	Prof./Depth 60 cm	198,8 x 169,6 x 106,9 cm	433.340.-.-
	Prof./Depth 60 cm	616,3 x 103,3 x 106,9 cm	433.355.-.-

# FINITIONS | ACABADOS | FINISHES

## REHAUSSE / SOBRE / COUNTER TOP | LATÉRAUX / LATERAL / PANEL LEG



Rehausse en mélamine Sobre mostrador en melamina Melamine counter top	053	Blanc Blanco White	054	Gris Gris Grey	055	Hêtre Haya Beech	061	Chêne Moyen Roble Maple	062	Poirier Peral Pear	063	Wengué Wengue
	103	Acacia Clair Acacia Clara Light Acacia	104	Acacia Foncé Acacia Oscura Dark Acacia	007	Graphite Grafito Graphite						
Rehausse en verre Sobre mostrador en vidrio Glass counter top	453	Blanc Blanco White	454	Gris Gris Grey	455	Hêtre Haya Beech	461	Chêne Moyen Roble Maple	462	Poirier Peral Pear	463	Wengué Wengue
	793	Acacia Clair Acacia Clara Light Acacia	794	Acacia Foncé Acacia Oscura Dark Acacia	487	Graphite Grafito Graphite						



# MODÈLES | VARIANTES | VERSIONS

UN SEUL PANNEAU - ROCK 4 / UNIPANEL - ROCK 4 / SINGLE PANEL - ROCK 4

MODÈLE / VARIANTES / VERSIONS	TYPE / TIPO / TYPE	DIMENSIONS / MEDIDAS / MEASUREMENTS	RÉFÉRENCE / REFERENCIA / CODE
	Prof./Depth 60 cm	200,6 x 100 x 106,9 cm	443.144. - - -
	Prof./Depth 60 cm	318,8 x 99,4 x 106,9 cm	443.145. - - -
	Prof./Depth 60 cm	278,8 x 120 x 106,9 cm	443.146. - - -
	Prof./Depth 60 cm	299,4 x 194,7 x 106,9 cm	443.147. - - -
	Prof./Depth 60 cm	299,4 x 175,5 x 106,9 cm	443.148. - - -
	Prof./Depth 60 cm	296,4 x 175,5 x 106,9 cm	443.149. - - -
	Prof./Depth 60 cm	296,4 x 195,2 x 106,9 cm	443.150. - - -
	Prof./Depth 60 cm	350,7 x 175,5 x 106,9 cm	443.151. - - -

MODÈLE / VARIANTES / VERSIONS	TYPE / TIPO / TYPE	DIMENSIONS / MEDIDAS / MEASUREMENTS	RÉFÉRENCE / REFERENCIA / CODE
	Prof./Depth 60 cm	375,4 x 103,3 x 106,9 cm	443.154. - - -
	Prof./Depth 60 cm	616,3 x 103,3 x 106,9 cm	443.155. - - -

# FINITIONS | ACABADOS | FINISHES



REHAUSSE / SOBRE / COUNTER TOP | LATÉRAUX / LATERAL / FRAME

REHAUSSE / SOBRE / COUNTER TOP	LATÉRAUX / LATERAL / FRAME																													
Rehausse en mélamine Sobre mostrador en melamina Melamine counter top	<table border="1"> <tr> <td>060</td> <td>Blanc Blanco White</td> <td>064</td> <td>Gris Gris Grey</td> <td>065</td> <td>Hêtre Haya Beech</td> <td>066</td> <td>Chêne Moyen Roble Maple</td> <td>067</td> <td>Poirier Peral Pear</td> </tr> <tr> <td>068</td> <td>Wengué Wengue</td> <td>706</td> <td>Acacia Clair Acacia Clara Light Acacia</td> <td>707</td> <td>Acacia Foncé Acacia Oscura Dark Acacia</td> <td>007</td> <td>Graphite Grafito Graphite</td> <td></td> <td></td> </tr> <tr> <td>096</td> <td>Blanc Blanco White</td> <td></td> <td></td> <td></td> <td></td> <td></td> <td></td> <td></td> </tr> </table>	060	Blanc Blanco White	064	Gris Gris Grey	065	Hêtre Haya Beech	066	Chêne Moyen Roble Maple	067	Poirier Peral Pear	068	Wengué Wengue	706	Acacia Clair Acacia Clara Light Acacia	707	Acacia Foncé Acacia Oscura Dark Acacia	007	Graphite Grafito Graphite			096	Blanc Blanco White							
	060	Blanc Blanco White	064	Gris Gris Grey	065	Hêtre Haya Beech	066	Chêne Moyen Roble Maple	067	Poirier Peral Pear																				
	068	Wengué Wengue	706	Acacia Clair Acacia Clara Light Acacia	707	Acacia Foncé Acacia Oscura Dark Acacia	007	Graphite Grafito Graphite																						
096	Blanc Blanco White																													
Rehausse en verre Sobre mostrador en vidrio Glass counter top	<table border="1"> <tr> <td>460</td> <td>Blanc Blanco White</td> <td>464</td> <td>Gris Gris Grey</td> <td>465</td> <td>Hêtre Haya Beech</td> <td>466</td> <td>Chêne Moyen Roble Maple</td> <td>467</td> <td>Poirier Peral Pear</td> </tr> <tr> <td>468</td> <td>Wengué Wengue</td> <td>805</td> <td>Acacia Clair Acacia Clara Light Acacia</td> <td>806</td> <td>Acacia Foncé Acacia Oscura Dark Acacia</td> <td>268</td> <td>Graphite Grafito Graphite</td> <td></td> <td></td> </tr> <tr> <td>496</td> <td>Blanc Blanco White</td> <td></td> <td></td> <td></td> <td></td> <td></td> <td></td> <td></td> </tr> </table>	460	Blanc Blanco White	464	Gris Gris Grey	465	Hêtre Haya Beech	466	Chêne Moyen Roble Maple	467	Poirier Peral Pear	468	Wengué Wengue	805	Acacia Clair Acacia Clara Light Acacia	806	Acacia Foncé Acacia Oscura Dark Acacia	268	Graphite Grafito Graphite			496	Blanc Blanco White							
	460	Blanc Blanco White	464	Gris Gris Grey	465	Hêtre Haya Beech	466	Chêne Moyen Roble Maple	467	Poirier Peral Pear																				
	468	Wengué Wengue	805	Acacia Clair Acacia Clara Light Acacia	806	Acacia Foncé Acacia Oscura Dark Acacia	268	Graphite Grafito Graphite																						
496	Blanc Blanco White																													

# MODÈLES | VARIANTES | VERSIONS

## MULTI PANNEAUX - ROCK 4 / MULTIPANEL - ROCK 4 / MULTI PANEL - ROCK 4

MODÈLE / VARIANTES / VERSIONS	TYPE / TIPO / TYPE	DIMENSIONS / MEDIDAS / MEASUREMENTS	RÉFÉRENCE / REFERENCIA / CODE
	Prof./Depth 60 cm	200,6 x 100 x 106,9 cm	443.344.-.-
	Prof./Depth 60 cm	318,8 x 99,4 x 106,9 cm	443.345.-.-
	Prof./Depth 60 cm	278,8 x 120 x 106,9 cm	443.346.-.-
	Prof./Depth 60 cm	299,4 x 194,7 x 106,9 cm	443.347.-.-
	Prof./Depth 60 cm	299,4 x 175,5 x 106,9 cm	443.348.-.-
	Prof./Depth 60 cm	296,4 x 175,5 x 106,9 cm	443.349.-.-
	Prof./Depth 60 cm	296,4 x 195,2 x 106,9 cm	443.350.-.-
	Prof./Depth 60 cm	350,7 x 175,5 x 106,9 cm	443.351.-.-

MODÈLE / VARIANTES / VERSIONS	TYPE / TIPO / TYPE	DIMENSIONS / MEDIDAS / MEASUREMENTS	RÉFÉRENCE / REFERENCIA / CODE
	Prof./Depth 60 cm	375,4 x 103,3 x 106,9 cm	443.354.-.-
	Prof./Depth 60 cm	616,3 x 103,3 x 106,9 cm	443.355.-.-

# FINITIONS | ACABADOS | FINISHES

## REHAUSSE / SOBRE / COUNTER TOP | LATÉRAUX / LATERAL / FRAME

REHAUSSE / SOBRE / COUNTER TOP	LATÉRAUX / LATERAL / FRAME																													
Rehausse en mélamine Sobre mostrador en melamina Melamine counter top	<table border="1"> <tr> <td>060</td> <td>Blanc Blanco White</td> <td>064</td> <td>Gris Gris Grey</td> <td>065</td> <td>Hêtre Haya Beech</td> <td>066</td> <td>Chêne Moyen Roble Maple</td> <td>067</td> <td>Poirier Peral Pear</td> </tr> <tr> <td>068</td> <td>Wengué Wengue</td> <td>706</td> <td>Acacia Clair Acacia Clara Light Acacia</td> <td>707</td> <td>Acacia Foncé Acacia Oscura Dark Acacia</td> <td>007</td> <td>Graphite Grafito Graphite</td> <td></td> <td></td> </tr> <tr> <td>096</td> <td>Blanc Blanco White</td> <td></td> <td></td> <td></td> <td></td> <td></td> <td></td> <td></td> </tr> </table>	060	Blanc Blanco White	064	Gris Gris Grey	065	Hêtre Haya Beech	066	Chêne Moyen Roble Maple	067	Poirier Peral Pear	068	Wengué Wengue	706	Acacia Clair Acacia Clara Light Acacia	707	Acacia Foncé Acacia Oscura Dark Acacia	007	Graphite Grafito Graphite			096	Blanc Blanco White							
	060	Blanc Blanco White	064	Gris Gris Grey	065	Hêtre Haya Beech	066	Chêne Moyen Roble Maple	067	Poirier Peral Pear																				
	068	Wengué Wengue	706	Acacia Clair Acacia Clara Light Acacia	707	Acacia Foncé Acacia Oscura Dark Acacia	007	Graphite Grafito Graphite																						
096	Blanc Blanco White																													
Rehausse en verre Sobre mostrador en vidrio Glass counter top	<table border="1"> <tr> <td>460</td> <td>Blanc Blanco White</td> <td>464</td> <td>Gris Gris Grey</td> <td>465</td> <td>Hêtre Haya Beech</td> <td>466</td> <td>Chêne Moyen Roble Maple</td> <td>467</td> <td>Poirier Peral Pear</td> </tr> <tr> <td>468</td> <td>Wengué Wengue</td> <td>805</td> <td>Acacia Clair Acacia Clara Light Acacia</td> <td>806</td> <td>Acacia Foncé Acacia Oscura Dark Acacia</td> <td>268</td> <td>Graphite Grafito Graphite</td> <td></td> <td></td> </tr> <tr> <td>496</td> <td>Blanc Blanco White</td> <td></td> <td></td> <td></td> <td></td> <td></td> <td></td> <td></td> </tr> </table>	460	Blanc Blanco White	464	Gris Gris Grey	465	Hêtre Haya Beech	466	Chêne Moyen Roble Maple	467	Poirier Peral Pear	468	Wengué Wengue	805	Acacia Clair Acacia Clara Light Acacia	806	Acacia Foncé Acacia Oscura Dark Acacia	268	Graphite Grafito Graphite			496	Blanc Blanco White							
	460	Blanc Blanco White	464	Gris Gris Grey	465	Hêtre Haya Beech	466	Chêne Moyen Roble Maple	467	Poirier Peral Pear																				
	468	Wengué Wengue	805	Acacia Clair Acacia Clara Light Acacia	806	Acacia Foncé Acacia Oscura Dark Acacia	268	Graphite Grafito Graphite																						
496	Blanc Blanco White																													

RANGEMENT  
ALMACENAJE  
STORAGE



406 | OH SYSTEMS



424 | METÁLICA



442 | LOK



456 | ORGATOWER

# OH Systems

Ordre et rangement définiront votre nouvel espace de travail. Grâce à sa grande variété de modèles et à ses multiples combinaisons OH Systems trouve sa place dans tous les bureaux.

Sistema modular de armarios. Orden y archivo definen el nuevo espacio de trabajo. OH Systems se adapta a cualquier oficina gracias a la gran variedad de modelos y a las múltiples combinaciones.

Tidiness and a good filing organization will improve the working space. A huge variety of functional types with Oh Systems drillings can match in any office.

## MODULE / MÓDULO / STORAGE

Mélamine / Melamina / Melamine: 25 mm  
Chant en ABS / Canto ABS / ABS edges

## FINITION STRUCTURE / ACABADO ESTRUCTURA / FRAME FINISH

Mélamine  
Melamina  
Melamine

## HAUTEUR / ALTURA / HEIGHT

Fixe:  
Fija: 41'5, 73, 81, 120, 158, 196, 235 cm  
Fixed:



ARMOIRES  
PUSH OPEN

ARMARIOS  
PUSH OPEN

PUSH OPEN  
CABINETS

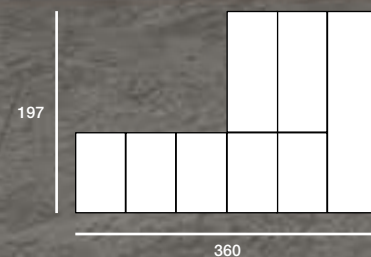



ARMOIRES  
OUVERTES

ARMARIOS  
HUECO

SHELVES  
CABINETS

La cremallière des armoires OH Systems permet de placer les étagères et d'autres accessoires tout les 32 mm.

El sistema OH Systems permite colocar estantes y otros complementos cada 32 mm.

OH Systems drilling pattern permit to hang shelves every 32 mm.

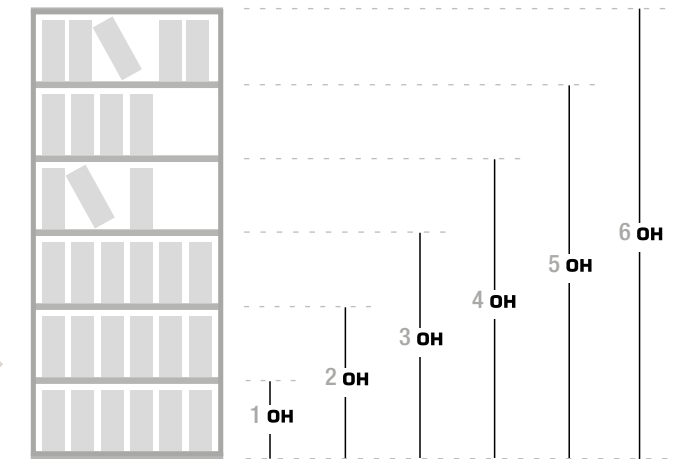
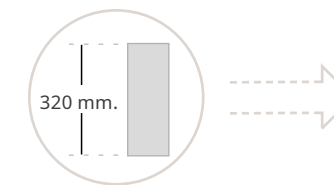

Option étagère fixe.  
Opción estante fijo.  
Fixed shelf.



Option étagère normale.  
Opción estante móvil.  
Normal shelf.

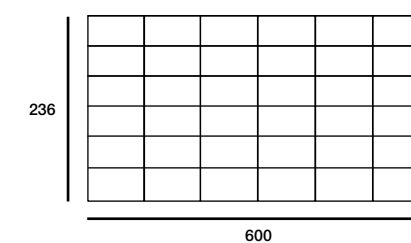

| ARMOIRES OUVERTES -  
| PORTES OU DS

| ARMARIOS HUECO -  
| PUERTAS O ARCHIVO

| CABINET WITH SHELVES  
| AND DOORS OR FILES

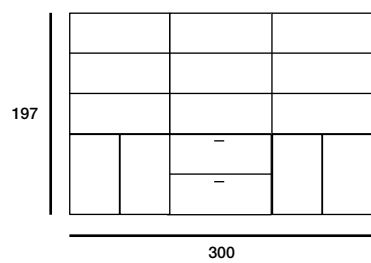



PORTES  
EN VERRE

PUERTAS  
DE VIDRIO

GLASS  
DOORS



Détail poignées  
Detalle tiradores  
Handles detail



Portes push open  
Puertas push open  
Push open doors

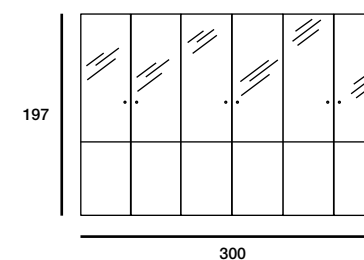



DOSSIERS  
SUSPENDUS

ARCHIVOS

FILES

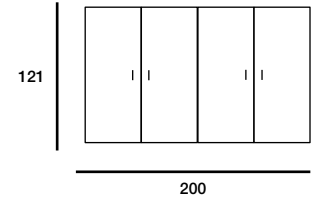
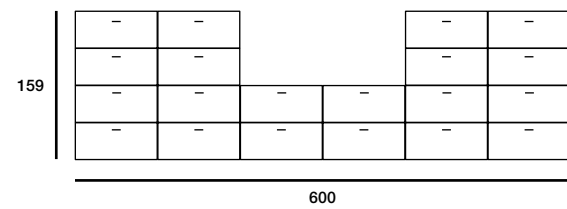

ARMOIRES  
PORTES  
BATTANTES

ARMARIOS  
CON  
PUERTAS

CABINETS  
WITH  
DOORS





| CAISSON  
| MÉLAMINE

| CAJONERA  
| MELAMINA

| MELAMINE  
| PEDESTAL



| Deux types de poignées disponibles.  
| Tirador disponible en dos modelos.  
| Two types of handles available.

| CAISSON PORTEUR  
| CAJONERA SOPORTANTE  
| FIXED PEDESTAL

L'intérieur du tiroir peut être en mélamine ou en métal.  
Pueden ser con cajón interior de melamina o de metal.  
Melamine or metal slide for drawers.



| CAISSON À ROULETTES  
| CAJONERA CON RUEDAS  
| MOBILE PEDESTALS

Roulettes visibles ou non visibles.  
Las ruedas puedan ser vistas u ocultas.  
Available with hidden wheels.



| CRÉDENCE MÉLAMINÉE  
| CREDENCIA MELAMINA  
| MELAMINE CREDENZA

Espace pour UC + porte coulissante + tiroirs.  
Con hueco para CPU + puerta corredera + cajones.  
With CPU gap + sliding door + drawers.



| ACCESSOIRES CAISSONS  
| ACCESORIOS PARA CUBETAS  
| PEDESTAL ACCESSORIES

# MODÈLES | VARIANTES | VERSIONS

## ARMOIRES / ARMARIOS / CABINETS

ÉTAGÈRES INCLUSES / ESTANTES INCLUIDOS / INCLUDED SHELVES

MODÈLE / VARIANTES / VERSIONS	TYPE / TIPO / TYPE	H.	RÉFÉRENCE / REFERENCIA / CODE	
	Prof./ Depth. 42 cm		L. 100 cm	L. 80 cm
Armoire ouverte avec étagères Armario hueco Shelves cabinet		236 cm	764.021.-..	764.037.-..
		197 cm	764.023.-..	764.039.-..
		159 cm	764.025.-..	764.041.-..
		121 cm	764.027.-..	764.043.-..
		82,5 cm	764.029.-..	764.045.-..
		73 cm	765.749.-..	765.751.-..
	43,5 cm	765.031.-..	765.047.-..	
	Prof./ Depth. 42 cm			
Armoire portes battantes Armario con puertas batientes Hinged doors cabinet		236 cm	764.103.-..	764.133.-..
		197 cm	764.107.-..	764.137.-..
		159 cm	764.111.-..	764.141.-..
		121 cm	764.115.-..	764.145.-..
		82,5 cm	764.119.-..	764.149.-..
		73 cm	765.761.-..	765.765.-..
	43,5 cm	765.123.-..	765.153.-..	
	Prof./ Depth. 42 cm			
Armoire portes push-open Armario push open Push open door cabinet		236 cm	763.103.-..	763.133.-..
		197 cm	763.107.-..	763.137.-..
		159 cm	763.111.-..	763.141.-..
		121 cm	763.115.-..	763.145.-..
		82,5 cm	763.119.-..	763.149.-..
		73 cm	767.761.-..	767.765.-..
	43,5 cm	767.123.-..	767.153.-..	
	Prof./ Depth. 45 cm	121 cm	364.259.-..	
Armoire portes coulissantes Puertas correderas Sliding doors cabinet		82,5 cm	364.261.-..	
		43,5 cm	365.263.-..	
	Prof./ Depth. 45 cm			
Armoire à rideaux Puertas persiana Tambour doors cabinet		197 cm	364.687.-..	
		159 cm	364.689.-..	
		121 cm	364.691.-..	
		82,5 cm	364.693.-..	
		73 cm	365.773.-..	
	43,5 cm	365.695.-..		
	Prof./ Depth. 60 cm	197 cm	365.729.-..	
Penderie Ropero Wardrobe		159 cm	365.731.-..	

# MODÈLES | VARIANTES | VERSIONS

## ARMOIRES / ARMARIOS / CABINETS

ÉTAGÈRES INCLUSES / ESTANTES INCLUIDOS / INCLUDED SHELVES

MODÈLE / VARIANTES / VERSIONS	TYPE / TIPO / TYPE	H.	RÉFÉRENCE / REFERENCIA / CODE	
	Prof./ Depth. 42 cm		L. 100 cm	L. 80 cm
Armoire DS Archivo File cabinet		159 cm	765.283.-..	765.291.-..
		121 cm	765.285.-..	765.293.-..
		82,5 cm	765.287.-..	765.295.-..
	Prof./ Depth. 42 cm			
Armoire ouverte - portes Hueco - puertas Shelves with low doors		236 cm	764.519.-..	764.541.-..
		197 cm	764.523.-..	764.545.-..
		159 cm	764.527.-..	764.549.-..

# FINITIONS | ACABADOS | FINISHES

DESSOUS, JONES ET FOND  
BAJO, LATERALES Y TRASERA  
BOTTOM, SIDE AND BACK PANELS

TOP ET ÉTAGÈRES  
TAPA Y ESTANTE  
TOP AND DIVIDER SHELF

Argent Plata Silver	051	Argent Plata Silver	075	Blanc Blanco White	054	Gris Gris Grey	055	Hêtre Haya Beech	061	Chêne Moyen Roble Maple
	062	Poirier Peral Pear	116	Wengué Wengue Wengue	694	Acacia Clair Acacia Clara Light Acacia	695	Acacia Foncé Acacia Oscura Dark Acacia	125	Graphite Grafito Graphite
	209	Chêne Veiné Castaño Claro Oak	235	Chêne Grisê Castaño Oscuro Dark Oak						
Blanc Blanco White	088	Argent Plata Silver	053	Blanc Blanco White	076	Gris Gris Grey	077	Hêtre Haya Beech	078	Chêne Moyen Roble Maple
	079	Poirier Peral Pear	080	Wengué Wengue Wengue	168	Acacia Clair Acacia Clara Light Acacia	169	Acacia Foncé Acacia Oscura Dark Acacia	115	Graphite Grafito Graphite
	043	Chêne Veiné Castaño Claro Oak	106	Chêne Grisê Castaño Oscuro Dark Oak						
Graphite Grafito Graphite	228	Argent Plata Silver	229	Blanc Blanco White	230	Gris Gris Grey	231	Hêtre Haya Beech	232	Chêne Moyen Roble Maple
	234	Poirier Peral Pear	700	Acacia Clair Acacia Clara Light Acacia	701	Acacia Foncé Acacia Oscura Dark Acacia	204	Graphite Grafito Graphite	251	Chêne Veiné Castaño Claro Oak
	252	Chêne Grisê Castaño Oscuro Dark Oak								
Monochrome Monocolor Single-colour	197	Gris Gris Grey	198	Hêtre Haya Beech	199	Chêne Moyen Roble Maple	200	Poirier Peral Pear	202	Wengué Wengue Wengue
	103	Acacia Clair Acacia Clara Light Acacia	104	Acacia Foncé Acacia Oscura Dark Acacia	209	Chêne Veiné Castaño Claro Oak	235	Chêne Grisê Castaño Oscuro Dark Oak		

# MODÈLES | VARIANTES | VERSIONS

## ARMOIRES / ARMARIOS / CABINETS

ÉTAGÈRES INCLUSES / ESTANTES INCLUIDOS / INCLUDED SHELVES

MODÈLE / VARIANTES / VERSIONS	TYPE / TIPO / TYPE	H.	RÉFÉRENCE / REFERENCIA / CODE	
	Prof./ Depth. 42 cm	197 cm 159 cm	L. 100 cm 764.643.-... 764.645.-...	L. 80 cm 764.655.-... 764.657.-...
<b>Armoire ouverte - DS</b> Hueco - archivo Shelves with low files				
	Prof./ Depth. 42 cm	236 cm 197 cm 159 cm	763.519.-... 763.523.-... 763.527.-...	763.541.-... 763.545.-... 763.549.-...
<b>Armoire ouverte - portes en verre</b> Hueco - puertas push open Shelves with low push open doors				

# FINITIONS | ACABADOS | FINISHES

DESSOUS, JOUES ET FOND  
BAJO, LATERALES Y TRASERA  
BOTTOM, SIDE AND BACK PANELS

TOP ET ÉTAGÈRES  
TAPA Y ESTANTE  
TOP AND DIVIDER SHELF

	<b>051</b> Argent Plata Silver	<b>075</b> Blanc Blanco White	<b>054</b> Gris Gris Grey	<b>055</b> Hêtre Haya Beech	<b>061</b> Chêne Moyen Roble Maple
	<b>062</b> Poirier Peral Pear	<b>116</b> Wengué Wengue Wengue	<b>694</b> Acacia Clair Acacia Clara Light Acacia	<b>695</b> Acacia Foncé Acacia Oscura Dark Acacia	<b>125</b> Graphite Grafito Graphite
	<b>209</b> Chêne Veiné Castaño Claro Oak	<b>235</b> Chêne Grisé Castaño Oscuro Dark Oak			
	<b>088</b> Argent Plata Silver	<b>053</b> Blanc Blanco White	<b>076</b> Gris Gris Grey	<b>077</b> Hêtre Haya Beech	<b>078</b> Chêne Moyen Roble Maple
	<b>079</b> Poirier Peral Pear	<b>080</b> Wengué Wengue Wengue	<b>168</b> Acacia Clair Acacia Clara Light Acacia	<b>169</b> Acacia Foncé Acacia Oscura Dark Acacia	<b>115</b> Graphite Grafito Graphite
	<b>043</b> Chêne Veiné Castaño Claro Oak	<b>106</b> Chêne Grisé Castaño Oscuro Dark Oak			
	<b>228</b> Argent Plata Silver	<b>229</b> Blanc Blanco White	<b>230</b> Gris Gris Grey	<b>231</b> Hêtre Haya Beech	<b>232</b> Chêne Moyen Roble Maple
	<b>234</b> Poirier Peral Pear	<b>700</b> Acacia Clair Acacia Clara Light Acacia	<b>701</b> Acacia Foncé Acacia Oscura Dark Acacia	<b>204</b> Graphite Grafito Graphite	<b>251</b> Chêne Veiné Castaño Claro Oak
	<b>252</b> Chêne Grisé Castaño Oscuro Dark Oak				
	<b>197</b> Gris Gris Grey	<b>198</b> Hêtre Haya Beech	<b>199</b> Chêne Moyen Roble Maple	<b>200</b> Poirier Peral Pear	<b>202</b> Wengué Wengue Wengue
	<b>103</b> Acacia Clair Acacia Clara Light Acacia	<b>104</b> Acacia Foncé Acacia Oscura Dark Acacia	<b>209</b> Chêne Veiné Castaño Claro Oak	<b>235</b> Chêne Grisé Castaño Oscuro Dark Oak	

# MODÈLES | VARIANTES | VERSIONS

## ARMOIRES VERRE / ARMARIOS VIDRIO / GLASS DOORS

ÉTAGÈRES INCLUSES / ESTANTES INCLUIDOS / INCLUDED SHELVES

MODÈLE / VARIANTES / VERSIONS	TYPE / TIPO / TYPE	H.	RÉFÉRENCE / REFERENCIA / CODE	
	Prof./ Depth. 42 cm	197 cm 159 cm 121 cm 82,5 cm	L. 100 cm 764.207.-... 764.209.-... 764.211.-... 764.213.-...	
<b>Armoire portes en verre</b> Armario con puertas vidrio Glass doors cabinet				
	Prof./ Depth. 42 cm	236 cm 197 cm 159 cm	764.595.-... 764.597.-... 764.599.-...	
<b>Armoire ouverte - portes en verre</b> Hueco - puertas vidrio Shelves with low glass doors				

# FINITIONS | ACABADOS | FINISHES

PORTES EN VERRE  
PUERTAS EN VIDRIO  
GLASS DOORS

CORPS ARMOIRE  
ARMAZÓN LIBRERÍA  
FRAME

	TYPE / TIPO / TYPE A						TYPE / TIPO / TYPE B					
	<b>601</b> Blanc Blanco White	<b>602</b> Gris Gris Grey	<b>603</b> Hêtre Haya Beech	<b>604</b> Chêne Moyen Roble Maple	<b>605</b> Poirier Peral Pear	<b>600</b> Argent Plata Silver						
	<b>606</b> Wengué Wengue Wengue	<b>439</b> Acacia Clair Acacia Clara Light Acacia	<b>442</b> Acacia Foncé Acacia Oscura Dark Acacia	<b>607</b> Graphite Grafito Graphite	<b>864</b> Chêne Veiné Castaño Claro Oak							
	<b>865</b> Chêne Grisé Castaño Oscuro Dark Oak											
	<b>613</b> Blanc Blanco White	<b>614</b> Gris Gris Grey	<b>615</b> Hêtre Haya Beech	<b>616</b> Chêne Moyen Roble Maple	<b>617</b> Poirier Peral Pear	<b>612</b> Argent Plata Silver						
	<b>618</b> Wengué Wengue Wengue	<b>440</b> Acacia Clair Acacia Clara Light Acacia	<b>443</b> Acacia Foncé Acacia Oscura Dark Acacia	<b>619</b> Graphite Grafito Graphite	<b>866</b> Chêne Veiné Castaño Claro Oak							
	<b>867</b> Chêne Grisé Castaño Oscuro Dark Oak											
	<b>637</b> Blanc Blanco White	<b>638</b> Gris Gris Grey	<b>639</b> Hêtre Haya Beech	<b>640</b> Chêne Moyen Roble Maple	<b>641</b> Poirier Peral Pear	<b>636</b> Argent Plata Silver						
	<b>642</b> Wengué Wengue Wengue	<b>793</b> Acacia Clair Acacia Clara Light Acacia	<b>794</b> Acacia Foncé Acacia Oscura Dark Acacia	<b>643</b> Graphite Grafito Graphite	<b>868</b> Chêne Veiné Castaño Claro Oak							
	<b>869</b> Chêne Grisé Castaño Oscuro Dark Oak											
	<b>453</b> Blanc Blanco White	<b>454</b> Gris Gris Grey	<b>455</b> Hêtre Haya Beech	<b>461</b> Chêne Moyen Roble Maple	<b>462</b> Poirier Peral Pear	<b>451</b> Argent Plata Silver						
	<b>486</b> Wengué Wengue Wengue	<b>796</b> Acacia Clair Acacia Clara Light Acacia	<b>797</b> Acacia Foncé Acacia Oscura Dark Acacia	<b>487</b> Graphite Grafito Graphite	<b>297</b> Chêne Veiné Castaño Claro Oak							
	<b>298</b> Chêne Grisé Castaño Oscuro Dark Oak											

# MODÈLES | VARIANTES | VERSIONS

## CAISSONS / CAJONERAS / PEDESTALS

MODÈLE / VARIANTES / VERSIONS	TYPE / TIPO / TYPE	DIMENSIONS / MEDIDAS / MEASUREMENTS	RÉFÉRENCE / REFERENCIA / CODE	
		Prof./ Depth. 80 cm	4 Tiroirs / Cajones / Drawers	2 Tiroirs / Cajones / Drawers + 1 DS / Archivo / File
	Haut de gamme / Gama alta / Top range Gamme basique / Gama básica / Basic range Gamme mélamine / Gama madera / Melamine drawer	44 x 73 cm 44 x 73 cm 44 x 73 cm	402.400.--- 402.402.--- 402.404.---	402.401.--- 402.403.--- 402.405.---
<b>Caisson HB top rectangulaire Cajonera adosada Fixed pedestal with top</b>		Prof./ Depth. 60 cm		
	Haut de gamme / Gama alta / Top range Gamme basique / Gama básica / Basic range Gamme mélamine / Gama madera / Melamine drawer	44 x 73 cm 44 x 73 cm 44 x 73 cm	402.342.--- 402.352.--- 402.363.---	402.343.--- 402.353.--- 402.364.---
<b>Caisson avec top en arc Cajonera con sobre en forma arco Fixed pedestal with bow font</b>		Prof./ Depth. 60 cm		
	Haut de gamme / Gama alta / Top range Gamme basique / Gama básica / Basic range Gamme mélamine / Gama madera / Melamine drawer	44 x 73 cm 44 x 73 cm 44 x 73 cm	402.410.--- 402.412.--- 402.414.---	402.411.--- 402.413.--- 402.415.---
<b>Caisson porteur Cajonera soportante Fixed pedestal (under desk top)</b>		Prof./ Depth. 80 cm	4 Tiroirs / Cajones / Drawers	2 Tiroirs / Cajones / Drawers + 1 DS / Archivo / File
	Haut de gamme / Gama alta / Top range Gamme basique / Gama básica / Basic range Gamme mélamine / Gama madera / Melamine drawer	43 x 70,5 cm 43 x 70,5 cm 43 x 70,5 cm	402.300.--- 402.310.--- 402.320.---	402.301.--- 402.311.--- 402.321.---
<b>Caisson à roulettes Cajonera con ruedas Mobile pedestal</b>		Prof./ Depth. 60 cm		
	Haut de gamme / Gama alta / Top range Gamme basique / Gama básica / Basic range Gamme mélamine / Gama madera / Melamine drawer	43 x 70,5 cm 43 x 70,5 cm 43 x 70,5 cm	402.302.--- 402.312.--- 402.323.---	402.303.--- 402.313.--- 402.324.---
		Roulette visibles / Ruedas visibles / Visible wheels	3 Tiroirs / Cajones / Drawers	1 Tiroir / Cajón / Drawer + 1 DS / Archivo / File
	Haut de gamme / Gama alta / Top range Gamme basique / Gama básica / Basic range Gamme mélamine / Gama madera / Melamine drawer	43,4 x 52,5 x 57,8 cm 43,4 x 52,5 x 57,8 cm 43,4 x 52,5 x 57,8 cm	402.304.--- 402.314.--- 402.326.---	402.305.--- 402.315.--- 402.327.---
		Roulettes non visibles / Ruedas ocultas / Hidden wheels		
	Haut de gamme / Gama alta / Top range Gamme basique / Gama básica / Basic range Gamme mélamine / Gama madera / Melamine drawer	43,6 x 52,5 x 57,6 cm 43,6 x 52,5 x 57,6 cm 43,6 x 52,5 x 57,6 cm 33 x 52,5 x 58,7 cm	402.306.--- 402.316.--- 402.328.--- 402.330.---	402.307.--- 402.317.--- 402.329.--- 402.331.---

## FINITIONS | ACABADOS | FINISHES

### CORPS / ESTRUCTURA / FRAME | FAÇADES ET TOP / DELANTERAS Y SOBRE / FRONTS AND TOP

Argent Plata Silver	051	Argent Plata Silver	053	Blanc Blanco White	054	Gris Gris Grey	055	Hêtre Haya Beech	061	Chêne Moyen Roble Maple
	062	Poirier Peral Pear	116	Wengué Wengue Wengue	694	Acacia Clair Acacia Clara Light Acacia	695	Acacia Foncé Acacia Oscura Dark Acacia	125	Graphite Grafito Graphite
	272	Chêne Veiné Castaño Claro Oak	273	Chêne Gris Castaño Oscuro Dark Oak						
Blanc Blanco White	088	Argent Plata Silver	053	Blanc Blanco White	076	Gris Gris Grey	077	Hêtre Haya Beech	078	Chêne Moyen Roble Maple
	079	Poirier Peral Pear	080	Wengué Wengue Wengue	168	Acacia Clair Acacia Clara Light Acacia	169	Acacia Foncé Acacia Oscura Dark Acacia	115	Graphite Grafito Graphite
	043	Chêne Veiné Castaño Claro Oak	106	Chêne Gris Castaño Oscuro Dark Oak						
Monochrome Monocolor Single-colour	197	Gris Gris Grey	198	Hêtre Haya Beech	199	Chêne Moyen Roble Maple	200	Poirier Peral Pear	202	Wengué Wengue Wengue
	103	Acacia Clair Acacia Clara Light Acacia	104	Acacia Foncé Acacia Oscura Dark Acacia	209	Chêne Veiné Castaño Claro Oak	235	Chêne Gris Castaño Oscuro Dark Oak		

# MODÈLES | VARIANTES | VERSIONS

## CRÉDENCE / CREDENCIA / CREDENZA

MODÈLE / VARIANTES / VERSIONS	TYPE / TIPO / TYPE	DIMENSIONS / MEDIDAS / MEASUREMENTS	RÉFÉRENCE / REFERENCIA / CODE	
		Gauche / Izquierda / Left	3 Tiroirs / Cajones / Drawers	1 Tiroir / Cajón / Drawer + 1 DS / Archivo / File
	Haut de gamme / Gama alta / Top range Gamme basique / Gama básica / Basic range Gamme mélamine / Gama madera / Melamine drawer	125,6 x 54,2 x 57,5 cm 125,6 x 54,2 x 57,5 cm 125,6 x 54,2 x 57,5 cm	362.405.--- 362.425.--- 362.445.---	362.407.--- 362.427.--- 362.447.---
<b>Crédence en mélamine Credencia de melamina Melamine credenza</b>		Droite / Derecha / Right		
	Haut de gamme / Gama alta / Top range Gamme basique / Gama básica / Basic range Gamme mélamine / Gama madera / Melamine drawer	125,6 x 54,2 x 57,5 cm 125,6 x 54,2 x 57,5 cm 125,6 x 54,2 x 57,5 cm	362.404.--- 362.424.--- 362.444.---	362.406.--- 362.426.--- 362.446.---

## FINITIONS | ACABADOS | FINISHES

### CORPS / ESTRUCTURA / FRAME | FAÇADES ET TOP / DELANTERAS Y SOBRE / FRONTS AND TOP

Blanc Blanco White	081	Blanc Blanco White	076	Gris Gris Grey	077	Hêtre Haya Beech	078	Chêne Moyen Roble Maple	079	Poirier Peral Pear
	080	Wengué Wengue Wengue	168	Acacia Clair Acacia Clara Light Acacia	169	Acacia Foncé Acacia Oscura Dark Acacia	043	Chêne Veiné Castaño Claro Oak	106	Chêne Gris Castaño Oscuro Dark Oak
Argent Plata Silver	053	Blanc Blanco White	054	Gris Gris Grey	055	Hêtre Haya Beech	061	Chêne Moyen Roble Maple	062	Poirier Peral Pear
	116	Wengué Wengue Wengue	694	Acacia Clair Acacia Clara Light Acacia	695	Acacia Foncé Acacia Oscura Dark Acacia	272	Chêne Veiné Castaño Claro Oak	273	Chêne Gris Castaño Oscuro Dark Oak
Monochrome Monocolor Single-colour	197	Gris Gris Grey	198	Hêtre Haya Beech	199	Chêne Moyen Roble Maple	200	Poirier Peral Pear	202	Wengué Wengue Wengue
	103	Acacia Clair Acacia Clara Light Acacia	104	Acacia Foncé Acacia Oscura Dark Acacia	209	Chêne Veiné Castaño Claro Oak	235	Chêne Gris Castaño Oscuro Dark Oak		

# metálica

METÁLICA est une série d'armoires métalliques pouvant être montées ou démontées. Elle dispose d'une grande variété de modèles et de finitions.

METÁLICA es una serie de armarios metálicos que se pueden adquirir montados o desmontados. Dispone de una amplia gama de tipos y acabados.

METÁLICA is a range of metal cabinets that can be ordered assembled or disassembled. It has a wide range of types and finishes.

ARMOIRES  
À RIDEAUX

ARMARIOS  
PERSIANA

TAMBOUR DOORS

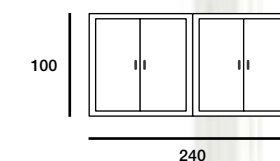
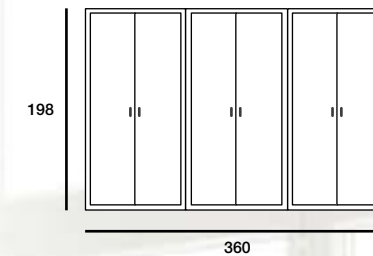

## MODULE / MÓDULO / STORAGE

Tôle laminée / Chapa laminada / Cold-rolled sheet 0,8 mm

## FINITION STRUCTURE / ACABADO ESTRUCTURA / FRAME FINISH

Peinture époxy  
Pintura epoxi  
Epoxy paint

## HAUTEUR / ALTURA / HEIGHT

Fixe:  
Fija: 50, 70, 100, 135, 160, 198 cm  
Fixed:

Poignée métallique  
(finition structure)  
Tirador metálico  
(acabado estructura)  
Metal handle  
(frame finish)

**BASIC**

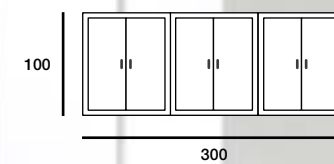

Poignée PVC  
(Fermeture magnétique)  
Tirador PVC  
(Cierre magnético)  
PVC handle  
(Magnetic closing)

**PLUS**

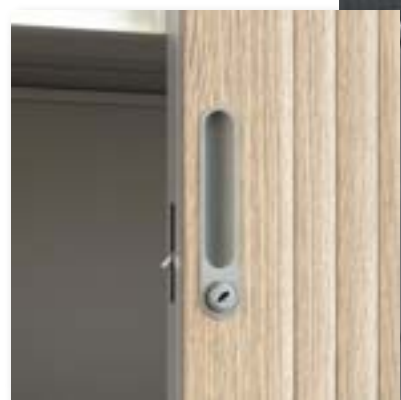

Tops d'union  
individuels et multiples  
Tapas individuales  
y múltiples  
Individual  
and multiple tops



| PENDERIE

| ROPERO

| WARDROBE

La distribution des étagères est idéale pour tous les besoins.

La disposición interior de los estantes del armario ropero es ideal para cualquier necesidad.

Shelves are ready to arrange any kind of clothing need.

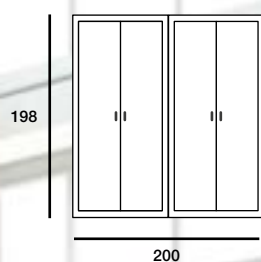

ARMOIRES  
DÉMONTÉES  
(RIDEAU)

ARMARIO  
DESMONTADO  
(PERSIANA)

DISASSEMBLED  
TAMBOUR DOORS  
CABINET

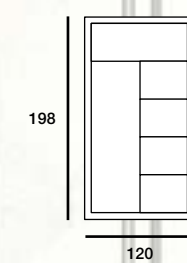

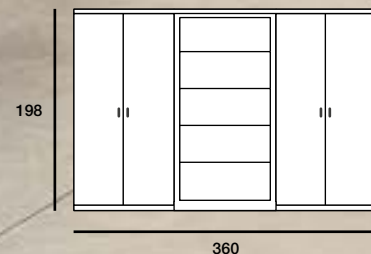

ARMOIRES  
OUVERTES -  
PORTES

ARMARIOS  
HUECO -  
PUERTAS

CABINET WITH  
SHELVES AND  
LOW DOORS





ARMOIRES DS  
TÉLESCOPIQUES

ARCHIVOS  
TELESCÓPICOS

TELESCOPIC  
FILES

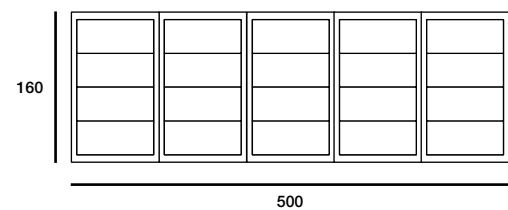
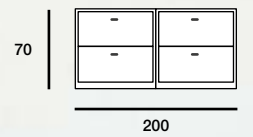

Réglage des tablettes intérieures chaque 25 mm.  
Laterales con cremallera cada 25 mm.  
Sides drilled every 25 mm.

ARMOIRE  
OUVERTE  
AVEC  
ÉTAGÈRES

ARMARIOS  
HUECO

SHELVES  
CABINET

Armoires pour les dossiers  
suspendus.  
Ideal para colgar carpetas  
For hanging folders.

CAISSON  
PORTEURS  
MÉTALLIQUES

CAJONERA  
METÁLICA  
SOPORTANTE

METAL  
FIXED  
PEDESTAL



Finitions métalliques: argent, blanc ou graphite.  
Disponible en tres acabados: plata, blanco o grafito.  
Available in three finishes: silver, white or graphite.

CAISSON HAUTEUR BUREAU  
CAJONERA METÁLICA ADOSADA  
FIXED PEDESTALS

Ouverture des tiroirs sans poignée.  
Sistema de apertura muy práctico sin tirador.  
Opening system is without handle.



CAISSON À ROULETTES  
CAJONERA CON RUEDAS  
MOBILE PEDESTAL

Une bonne solution pour avoir un meuble auxiliaire.  
Ideal como mueble auxiliar.  
It is a perfect solution as an auxiliar furniture.



CRÉDENCE MÉTALLIQUE  
CREDENCIA METÁLICA  
METAL CREDENZA

Espace pour UC + porte coulissante + tiroirs.  
Con hueco para CPU + puerta corredera + cajones.  
With CPU gap + sliding door + drawers.



ACCESSOIRES CAISSONS - PVC  
ACCESORIOS PARA CUBETAS  
PEDESTAL ACCESSORIES

# MODÈLES | VARIANTES | VERSIONS

## ARMOIRES BASIC / ARMARIOS BASIC / BASIC CABINETS

ÉTAGÈRES INCLUSES / ESTANTES INCLUIDOS / INCLUDED SHELVES

MODÈLE / VARIANTES / VERSIONS	TYPE / TIPO / TYPE	H.	RÉFÉRENCE / REFERENCIA / CODE		
	Prof./ Depth. 43 cm	198 cm	195.302.---	195.312.---	195.322.---
		160 cm	195.303.---	195.313.---	195.323.---
		135 cm	195.305.---	195.315.---	195.325.---
		100 cm	195.307.---	195.317.---	195.327.---
		70 cm	195.309.---	195.319.---	195.329.---
		50 cm	195.010.---	195.020.---	195.030.---

Armoires à rideaux  
Puertas persiana  
Tambour doors cabinet

MODÈLE / VARIANTES / VERSIONS	TYPE / TIPO / TYPE	H.	RÉFÉRENCE / REFERENCIA / CODE		
	Type / Tipo / Type A - B Prof./ Depth. 43 cm	198 cm	195.332.---		
		160 cm	195.333.---		

Penderie à rideaux  
Ropero con puertas persiana  
Wardrobe with tambour doors

# FINITIONS | ACABADOS | FINISHES

STRUCTURE ARMOIRE MÉTALLIQUE  
ESTRUCTURA LIBRERÍA EN METAL  
METAL FRAME

PVC TYPE / TIPO / TYPE A Rideaux: couleurs unies / Con persiana en acabado liso / Tambour door finishes: plain colors.  
TYPE / TIPO / TYPE B Rideaux: Couleurs métallisées et veinées / Con persiana en acabado metalizado o vetado / Tambour door finishes: metalized or veined colors.

BASIC	TYPE / TIPO / TYPE A				TYPE / TIPO / TYPE B			
	500 Gris Gris Grey	501 Blanc Blanco White	502 Argent Plata Silver	503 Hêtre Haya Beech	504 Chêne Moyen Roble Maple	505 Poirier Peral Pear	506 Wengué Wengue Wengue	754 Acacia Clair Acacia Clara Light Acacia
	347 Noir Negro Black		755 Acacia Foncé Acacia Oscura Dark Acacia	510 Graphite Grafito Graphite	478 Chêne Veiné Castaño Claro Oak	479 Chêne Grisé Castaño Oscuro Dark Oak		
	511 Gris Gris Grey	512 Blanc Blanco White	513 Argent Plata Silver	514 Hêtre Haya Beech	515 Chêne Moyen Roble Maple	516 Poirier Peral Pear	517 Wengué Wengue Wengue	757 Acacia Clair Acacia Clara Light Acacia
	348 Noir Negro Black		758 Acacia Foncé Acacia Oscura Dark Acacia	521 Graphite Grafito Graphite	850 Chêne Veiné Castaño Claro Oak	851 Chêne Grisé Castaño Oscuro Dark Oak		
	544 Gris Gris Grey	545 Blanc Blanco White	546 Argent Plata Silver	547 Hêtre Haya Beech	548 Chêne Moyen Roble Maple	549 Poirier Peral Pear	550 Wengué Wengue Wengue	760 Acacia Clair Acacia Clara Light Acacia
	349 Noir Negro Black		761 Acacia Foncé Acacia Oscura Dark Acacia	557 Graphite Grafito Graphite	856 Chêne Veiné Castaño Claro Oak	857 Chêne Grisé Castaño Oscuro Dark Oak		
	558 Gris Gris Grey	559 Blanc Blanco White	560 Argent Plata Silver	565 Hêtre Haya Beech	566 Chêne Moyen Roble Maple	567 Poirier Peral Pear	568 Wengué Wengue Wengue	763 Acacia Clair Acacia Clara Light Acacia
	350 Noir Negro Black		764 Acacia Foncé Acacia Oscura Dark Acacia	572 Graphite Grafito Graphite	858 Chêne Veiné Castaño Claro Oak	859 Chêne Grisé Castaño Oscuro Dark Oak		
	352 Gris Gris Grey	353 Blanc Blanco White	354 Argent Plata Silver	355 Hêtre Haya Beech	356 Chêne Moyen Roble Maple	357 Poirier Peral Pear	358 Wengué Wengue Wengue	363 Acacia Clair Acacia Clara Light Acacia
	351 Noir Negro Black		364 Acacia Foncé Acacia Oscura Dark Acacia	362 Graphite Grafito Graphite	382 Chêne Veiné Castaño Claro Oak	383 Chêne Grisé Castaño Oscuro Dark Oak		

# MODÈLES | VARIANTES | VERSIONS

## ARMOIRES PLUS / ARMARIOS PLUS / PLUS CABINETS

ÉTAGÈRES INCLUSES / ESTANTES INCLUIDOS / INCLUDED SHELVES

MODÈLE / VARIANTES / VERSIONS	TYPE / TIPO / TYPE	H.	RÉFÉRENCE / REFERENCIA / CODE		
	Prof./ Depth. 43 cm	198 cm	195.402.---	195.412.---	195.422.---
		160 cm	195.403.---	195.413.---	195.423.---
		135 cm	195.405.---	195.415.---	195.425.---
		100 cm	195.407.---	195.417.---	195.427.---
		70 cm	195.409.---	195.419.---	195.429.---
		50 cm	195.210.---	195.220.---	195.230.---

Armoires à rideaux  
Puertas persiana  
Tambour doors cabinet

MODÈLE / VARIANTES / VERSIONS	TYPE / TIPO / TYPE	H.	RÉFÉRENCE / REFERENCIA / CODE		
	Type / Tipo / Type E - F Prof./ Depth. 43 cm	198 cm	195.432.---		
		160 cm	195.433.---		

Penderie à rideaux  
Ropero con puertas persiana  
Wardrobe with tambour doors

# FINITIONS | ACABADOS | FINISHES

STRUCTURE ARMOIRE MÉTALLIQUE  
ESTRUCTURA LIBRERÍA EN METAL  
METAL FRAME







PVC TYPE / TIPO / TYPE E Rideaux: couleurs unies / Con persiana en acabado liso / Tambour door finishes: plain colors.  
TYPE / TIPO / TYPE F Rideaux: Couleurs métallisées et veinées / Con persiana en acabado metalizado o vetado / Tambour door finishes: metalized or veined colors.

PLUS	TYPE / TIPO / TYPE E				TYPE / TIPO / TYPE F			
	500 Gris Gris Grey	501 Blanc Blanco White	502 Argent Plata Silver	503 Hêtre Haya Beech	504 Chêne Moyen Roble Maple	505 Poirier Peral Pear	506 Wengué Wengue Wengue	754 Acacia Clair Acacia Clara Light Acacia
	347 Noir Negro Black		755 Acacia Foncé Acacia Oscura Dark Acacia	510 Graphite Grafito Graphite	478 Chêne Veiné Castaño Claro Oak	479 Chêne Grisé Castaño Oscuro Dark Oak		
	511 Gris Gris Grey	512 Blanc Blanco White	513 Argent Plata Silver	514 Hêtre Haya Beech	515 Chêne Moyen Roble Maple	516 Poirier Peral Pear	517 Wengué Wengue Wengue	757 Acacia Clair Acacia Clara Light Acacia
	348 Noir Negro Black		758 Acacia Foncé Acacia Oscura Dark Acacia	521 Graphite Grafito Graphite	850 Chêne Veiné Castaño Claro Oak	851 Chêne Grisé Castaño Oscuro Dark Oak		
	544 Gris Gris Grey	545 Blanc Blanco White	546 Argent Plata Silver	547 Hêtre Haya Beech	548 Chêne Moyen Roble Maple	549 Poirier Peral Pear	550 Wengué Wengue Wengue	760 Acacia Clair Acacia Clara Light Acacia
	349 Noir Negro Black		761 Acacia Foncé Acacia Oscura Dark Acacia	557 Graphite Grafito Graphite	856 Chêne Veiné Castaño Claro Oak	857 Chêne Grisé Castaño Oscuro Dark Oak		
	558 Gris Gris Grey	559 Blanc Blanco White	560 Argent Plata Silver	565 Hêtre Haya Beech	566 Chêne Moyen Roble Maple	567 Poirier Peral Pear	568 Wengué Wengue Wengue	763 Acacia Clair Acacia Clara Light Acacia
	350 Noir Negro Black		764 Acacia Foncé Acacia Oscura Dark Acacia	572 Graphite Grafito Graphite	858 Chêne Veiné Castaño Claro Oak	859 Chêne Grisé Castaño Oscuro Dark Oak		
	352 Gris Gris Grey	353 Blanc Blanco White	354 Argent Plata Silver	355 Hêtre Haya Beech	356 Chêne Moyen Roble Maple	357 Poirier Peral Pear	358 Wengué Wengue Wengue	363 Acacia Clair Acacia Clara Light Acacia
	351 Noir Negro Black		364 Acacia Foncé Acacia Oscura Dark Acacia	362 Graphite Grafito Graphite	382 Chêne Veiné Castaño Claro Oak	383 Chêne Grisé Castaño Oscuro Dark Oak		

# MODÈLES | VARIANTES | VERSIONS

## ARMOIRES / ARMARIOS / CABINETS

ÉTAGÈRES INCLUSES / ESTANTES INCLUIDOS / INCLUDED SHELVES

MODÈLE / VARIANTES / VERSIONS	TYPE / TIPO / TYPE	H.	RÉFÉRENCE / REFERENCIA / CODE		
	Prof./ Depth. 43 cm	198 cm	197.002.---	197.012.---	197.022.---
		160 cm	197.003.---	197.013.---	197.023.---
		135 cm	197.005.---	197.015.---	197.025.---
		100 cm	197.007.---	197.017.---	197.027.---
		70 cm	197.009.---	197.019.---	197.029.---
		50 cm	197.010.---	197.020.---	197.030.---
<b>Armoire ouverte avec étagères</b> Armario hueco Shelves cabinet					
	Prof./ Depth. 43 cm	198 cm	197.202.---	197.212.---	197.222.---
		160 cm	197.203.---	197.213.---	197.223.---
		135 cm	197.205.---	197.215.---	197.225.---
		100 cm	197.207.---	197.217.---	197.227.---
		70 cm	197.209.---	197.219.---	197.229.---
		50 cm	197.210.---	197.220.---	197.230.---
<b>Armoire portes battantes</b> Armario con puertas batientes Hinged doors cabinet					
	Prof./ Depth. 43 cm	198 cm	197.290.---		
		160 cm	197.292.---		
<b>Penderie portes battantes</b> Ropero con puertas Wardrobe with doors					
	Prof./ Depth. 43 cm	135 cm	197.240.---	197.246.---	197.252.---
		100 cm	197.242.---	197.248.---	197.254.---
		70 cm	197.244.---	197.250.---	197.256.---
<b>Armoire DS</b> Archivo File cabinet					
	Prof./ Depth. 43 cm	198 cm	197.272.---	197.276.---	197.280.---
		160 cm	197.274.---	197.278.---	197.282.---
		135 cm	197.275.---	197.279.---	197.284.---
<b>Armoire ouverte - portes</b> Hueco - puertas Shelves with low doors					
	Prof./ Depth. 43 cm	198 cm	197.260.---	197.264.---	197.268.---
		160 cm	197.262.---	197.266.---	197.270.---
		135 cm	197.263.---	197.267.---	197.271.---
<b>Armoire ouverte - DS</b> Hueco - archivo Shelves with low files					

FINITIONS  
ACABADOS  
FINISHES

303 RAL 7035 301 RAL 7015 111 RAL 9006 108 RAL 9016 124 RAL 9005

# FINITIONS | ACABADOS | FINISHES

STRUCTURE ARMOIRE MÉTALLIQUE  
ESTRUCTURA LIBRERÍA EN METAL  
METAL FRAME

JEU DE PORTES ET FAÇADES  
JUEGO DE PUERTAS Y DELANTERAS  
HINGED DOORS AND FRONTS

Gris Gris Grey

RAL 7035

388 Graphite Grafito Graphite 389 Argent Plata Silver 716 Noir Negro Black 390 Blanc Blanco White 391 Gris Gris Grey 392 Hêtre Haya Beech 393 Chêne Moyen Roble Maple 394 Poirier Peral Pear

395 Wengué Wengue Wengue 739 Acacia Clair Acacia Clara Light Acacia 740 Acacia Foncé Acacia Oscura Dark Acacia 287 Chêne Veiné Castaño Claro Oak 288 Chêne Grisé Castaño Oscuro Dark Oak

Graphite Grafito Graphite

RAL 7015

686 Graphite Grafito Graphite 687 Argent Plata Silver 717 Noir Negro Black 688 Blanc Blanco White 689 Gris Gris Grey 690 Hêtre Haya Beech 691 Chêne Moyen Roble Maple 692 Poirier Peral Pear

693 Wengué Wengue Wengue 742 Acacia Clair Acacia Clara Light Acacia 743 Acacia Foncé Acacia Oscura Dark Acacia 878 Chêne Veiné Castaño Claro Oak 879 Chêne Grisé Castaño Oscuro Dark Oak

Argent Plata Silver

RAL 9006

020 Graphite Grafito Graphite 040 Argent Plata Silver 718 Noir Negro Black 060 Blanc Blanco White 064 Gris Gris Grey 065 Hêtre Haya Beech 066 Chêne Moyen Roble Maple 067 Poirier Peral Pear

068 Wengué Wengue Wengue 706 Acacia Clair Acacia Clara Light Acacia 707 Acacia Foncé Acacia Oscura Dark Acacia 031 Chêne Veiné Castaño Claro Oak 032 Chêne Grisé Castaño Oscuro Dark Oak

Blanc Blanco White

RAL 9016

138 Graphite Grafito Graphite 095 Argent Plata Silver 719 Noir Negro Black 096 Blanc Blanco White 097 Gris Gris Grey 098 Hêtre Haya Beech 099 Chêne Moyen Roble Maple 100 Poirier Peral Pear

101 Wengué Wengue Wengue 709 Acacia Clair Acacia Clara Light Acacia 710 Acacia Foncé Acacia Oscura Dark Acacia 166 Chêne Veiné Castaño Claro Oak 167 Chêne Grisé Castaño Oscuro Dark Oak

Noir Negro Black

RAL 9005



165 Graphite Grafito Graphite 164 Argent Plata Silver 715 Noir Negro Black 102 Blanc Blanco White 153 Gris Gris Grey 154 Hêtre Haya Beech 155 Chêne Moyen Roble Maple 156 Poirier Peral Pear

158 Wengué Wengue Wengue 712 Acacia Clair Acacia Clara Light Acacia 713 Acacia Foncé Acacia Oscura Dark Acacia 189 Chêne Veiné Castaño Claro Oak 193 Chêne Grisé Castaño Oscuro Dark Oak



# MODÈLES | VARIANTES | VERSIONS

## CAISSONS / CAJONERAS / PEDESTALS

MODÈLE / VARIANTES / VERSIONS	TYPE / TIPO / TYPE	DIMENSIONS / MEDIDAS / MEASUREMENTS	RÉFÉRENCE / REFERENCIA / CODE
 Caisson HB top rectangulaire Cajonera adosada Fixed pedestal with top	Prof./ Depth. 62 cm	44 x 73 cm	4 Tiroirs / Cajones / Drawers 2 Tiroirs / Cajones / Drawers + 1 DS / Archivo / File  402.072.-.- 402.073.-.-
 Caisson HB top arc Cajonera adosada con sobre arco Fixed pedestal with bow top	Prof./ Depth. 62 cm	44 x 73 cm	402.074.-.- 402.075.-.-



# FINITIONS | ACABADOS | FINISHES

## CORPS / ESTRUCTURA / FRAME | TOP / SOBRES / TOP

 Argent Plata Silver RAL 9006	095 Argent Plata Silver	060 Blanc Blanco White	064 Gris Gris Grey	065 Hêtre Haya Beech	066 Chêne Moyen Roble Maple
	067 Poirier Peral Pear	068 Wengué Wengue	706 Acacia Clair Acacia Clara Light Acacia	707 Acacia Foncé Acacia Oscura Dark Acacia	020 Graphite Grafito Graphite
	031 Chêne Veiné Castaño Claro Oak	032 Chêne Grisê Castaño Oscuro Dark Oak			
 Blanc Blanco White RAL 9016	126 Argent Plata Silver	096 Blanc Blanco White	097 Gris Gris Grey	098 Hêtre Haya Beech	099 Chêne Moyen Roble Maple
	100 Poirier Peral Pear	101 Wengué Wengue	709 Acacia Clair Acacia Clara Light Acacia	710 Acacia Foncé Acacia Oscura Dark Acacia	127 Graphite Grafito Graphite
	166 Chêne Veiné Castaño Claro Oak	167 Chêne Grisê Castaño Oscuro Dark Oak			
 Graphite Grafito Graphite RAL 7022	160 Argent Plata Silver	163 Blanc Blanco White	180 Gris Gris Grey	181 Hêtre Haya Beech	182 Chêne Moyen Roble Maple
	183 Poirier Peral Pear	184 Wengué Wengue	715 Acacia Clair Acacia Clara Light Acacia	716 Acacia Foncé Acacia Oscura Dark Acacia	113 Graphite Grafito Graphite
	206 Chêne Veiné Castaño Claro Oak	208 Chêne Grisê Castaño Oscuro Dark Oak			

# MODÈLES | VARIANTES | VERSIONS

## CAISSONS / CAJONERAS / PEDESTALS

MODÈLE / VARIANTES / VERSIONS	TYPE / TIPO / TYPE	DIMENSIONS / MEDIDAS / MEASUREMENTS	RÉFÉRENCE / REFERENCIA / CODE
 Caisson porteur Cajonera soportante Fixex pedestal (under desk top)	Prof./ Depth. 55 cm	42 x 70,5 cm	4 Tiroirs / Cajones / Drawers 2 Tiroirs / Cajones / Drawers + 1 DS / Archivo / File  402.032.-.- 402.033.-.-
 Caisson à roulettes Cajonera con ruedas Mobile pedestal	Prof./ Depth. 55 cm	42 x 55 cm	402.036.-.- 402.037.-.-

# FINITIONS | ACABADOS | FINISHES

111 Argent Plata Silver RAL 9006	108 Blanc Blanco White RAL 9016	107 Graphite Grafito Graphite RAL 7022
-------------------------------------	------------------------------------	---



# MODÈLES | VARIANTES | VERSIONS

## CRÉDENCE / CREDENCIA / CREDENZA

MODÈLE / VARIANTES / VERSIONS	TYPE / TIPO / TYPE	DIMENSIONS / MEDIDAS / MEASUREMENTS	RÉFÉRENCE / REFERENCIA / CODE
 Crédence avec structure métallique Credencia con estructura metálica Metal structure credenza	Haut de gamme / Gama alta / Top range Gamme basique / Gama básica / Basic range Gamme mélamine / Gama madera / Melamine drawer	Gauche / Izquierda / Left	3 Tiroirs / Cajones / Drawers 1 Tiroir / Cajón / Drawer + 1 DS / Archivo / File 362.415.-.- 362.417.-.- 362.435.-.- 362.437.-.- 362.455.-.- 362.457.-.-
		Droite / Derecha / Right	362.414.-.- 362.416.-.- 362.434.-.- 362.436.-.- 362.454.-.- 362.456.-.-
		Haut de gamme / Gama alta / Top range Gamme basique / Gama básica / Basic range Gamme mélamine / Gama madera / Melamine drawer	125,6 x 54,2 x 57,5 cm 125,6 x 54,2 x 57,5 cm 125,6 x 54,2 x 57,5 cm

# FINITIONS | ACABADOS | FINISHES

## CORPS / ESTRUCTURA / FRAME | FAÇADES ET TOP / DELANTERAS Y SOBRE / FRONT AND TOP

 Blanc Blanco White RAL 9016	096 Blanc Blanco White	097 Gris Gris Grey	098 Hêtre Haya Beech	099 Chêne Moyen Roble Maple	100 Poirier Peral Pear
	101 Wengué Wengue	709 Acacia Clair Acacia Clara Light Acacia	710 Acacia Foncé Acacia Oscura Dark Acacia	206 Chêne Veiné Castaño Claro Oak	208 Chêne Grisê Castaño Oscuro Dark Oak
 Argent Plata Silver RAL 9006	060 Blanc Blanco White	064 Gris Gris Grey	065 Hêtre Haya Beech	066 Chêne Moyen Roble Maple	067 Poirier Peral Pear
	068 Wengué Wengue	706 Acacia Clair Acacia Clara Light Acacia	707 Acacia Foncé Acacia Oscura Dark Acacia	206 Chêne Veiné Castaño Claro Oak	208 Chêne Grisê Castaño Oscuro Dark Oak

# LOK

Lok est une série de casiers pour bureaux, hôtels, salles d'exposition, centres éducatifs, etc. Au bureau, il se présente comme une solution qui complète les besoins des postes de travail nomades et contemporains, offrant un rangement personnel pour des lieux flexibles.

LOK es una serie de taquillas para las oficinas, los hoteles, las salas de exposiciones, los centros educativos, etc. En la oficina se presenta como una solución que complementa las necesidades de los puestos de trabajo nómadas y contemporáneos, ofreciendo almacenaje personal para lugares flexibles.

LOK lockers for offices, hotels, exhibitionhalls, schools, etc. Good, secure lockers are indispensable in a modern office, which means that new ways of working do not necessarily require a permanent personal workplace.

## MODULE / MÓDULO / STORAGE

Mélamine / Melamina / Melamine: 25 mm  
Chant en ABS / Canto ABS / ABS edges

## FINITION STRUCTURE / ACABADO ESTRUCTURA / FRAME FINISH

Mélamine  
Melamina  
Melamine

## HAUTEUR / ALTURA / HEIGHT

Fixe:  
Fija:  
Fixed: 90'6, 133, 175 cm

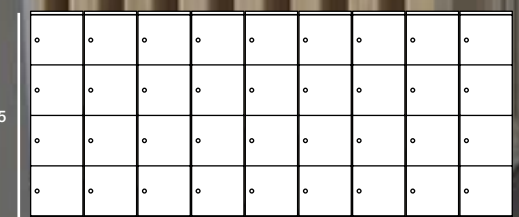



CASIERS  
AVEC FENTE

TAQUILLA  
CON BUZÓN

LOCKERS WITH  
MAIL-HOLE  
DOORS

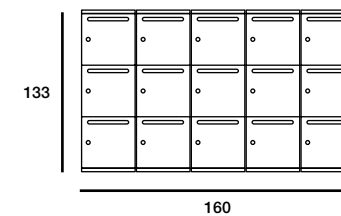



Cintre extensible: Pour vêtements.  
Perchero extensible: para ropa.  
Telescopic hanger: for clothes.

ARMOIRE  
PENDERIE

PERCHERO

HANGING  
CABINET

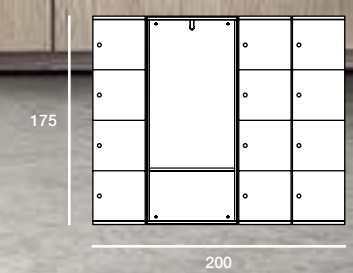



CASIERS AVEC  
SERRURE À  
COMBINAISON

TAQUILLAS CON  
COMBINACIÓN

LOCKERS WITH  
4-DIGIT LOCK

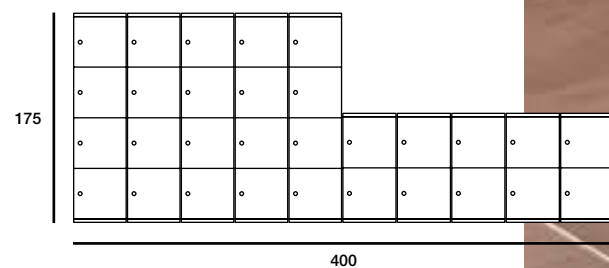

# MODÈLES | VARIANTES | VERSIONS

## CASIEROS MULTICOLORES / TAQUILLA MULTICOLOR / MULTICOLOR LOCKERS

MODÈLE / VARIANTES / VERSIONS	DIMENSIONS / MEDIDAS / MEASUREMENTS	RÉFÉRENCE / REFERENCIA / CODE									
	175 cm 133 cm 90,6 cm	<table border="0"> <tr> <td>695.010.051</td> <td>695.010.053</td> <td>695.010.007</td> </tr> <tr> <td>695.012.051</td> <td>695.012.053</td> <td>695.012.007</td> </tr> <tr> <td>695.014.051</td> <td>695.014.053</td> <td>695.014.007</td> </tr> </table>	695.010.051	695.010.053	695.010.007	695.012.051	695.012.053	695.012.007	695.014.051	695.014.053	695.014.007
695.010.051	695.010.053	695.010.007									
695.012.051	695.012.053	695.012.007									
695.014.051	695.014.053	695.014.007									
<p>Structure - Avec fente Estructura - Con buzón Structure - Mail-hole doors</p>											

	175 cm 133 cm 90,6 cm	<table border="0"> <tr> <td>695.030.051</td> <td>695.030.053</td> <td>695.030.007</td> </tr> <tr> <td>695.032.051</td> <td>695.032.053</td> <td>695.032.007</td> </tr> <tr> <td>695.034.051</td> <td>695.034.053</td> <td>695.034.007</td> </tr> </table>	695.030.051	695.030.053	695.030.007	695.032.051	695.032.053	695.032.007	695.034.051	695.034.053	695.034.007
695.030.051	695.030.053	695.030.007									
695.032.051	695.032.053	695.032.007									
695.034.051	695.034.053	695.034.007									
<p>Structure - Avec fente - sans top Estructura - Con buzón - sin tapa Structure - Mail-hole doors without top</p>											

MODÈLE / VARIANTES / VERSIONS	SERRURES / CERRADURA / LOCK TYPES	TYPE / TIPO / TYPE	RÉFÉRENCE / REFERENCIA / CODE
P1 P2 P3 P4 	CLÉ / LLAVE / KEY	P1 P2 P3 P4	1.695.101... 1.695.102... 1.695.103... 1.695.104...
	COMBINAISON / COMBINACIÓN / 4-DIGIT LOCK	P1 P2 P3 P4	1.695.201... 1.695.202... 1.695.203... 1.695.204...
	CARTE RFID / TARJETA RFID / RFID CARD	P1 P2 P3 P4	1.695.301... 1.695.302... 1.695.303... 1.695.304...
	ELECTRONIQUE / ELECTRÓNICA / ELECTRONIC	P1 P2 P3 P4	1.695.401... 1.695.402... 1.695.403... 1.695.404...
<p>Porte avec fente boîte aux lettres Puertas con buzón Mail-hole doors</p>			

# FINITIONS | ACABADOS | FINISHES

## STRUCTURE / ESTRUCTURA / FRAME | PORTE / PUERTA / DOORS

	Argent Plata Silver		Blanc Blanco White		Gris Gris Grey		Hêtre Haya Beech		Chêne Moyen Roble Maple
	Blanc Blanco White		Gris Gris Grey		Noir Negro Black		Jaune Amarillo Yellow		Rouge Rojo Red
	Graphite Grafito Graphite		Vert Verde Green		Bleu Azul Blue				

# MODÈLES | VARIANTES | VERSIONS

## CASIEROS MULTICOLORES / TAQUILLA MULTICOLOR / MULTICOLOR LOCKERS

MODÈLE / VARIANTES / VERSIONS	DIMENSIONS / MEDIDAS / MEASUREMENTS	RÉFÉRENCE / REFERENCIA / CODE									
	175 cm 133 cm 90,6 cm	<table border="0"> <tr> <td>695.020.051</td> <td>695.020.053</td> <td>695.020.007</td> </tr> <tr> <td>695.022.051</td> <td>695.022.053</td> <td>695.022.007</td> </tr> <tr> <td>695.024.051</td> <td>695.024.053</td> <td>695.024.007</td> </tr> </table>	695.020.051	695.020.053	695.020.007	695.022.051	695.022.053	695.022.007	695.024.051	695.024.053	695.024.007
695.020.051	695.020.053	695.020.007									
695.022.051	695.022.053	695.022.007									
695.024.051	695.024.053	695.024.007									
<p>Structure - Sans fente Estructura - Sin buzón Structure - Doors</p>											

	175 cm 133 cm 90,6 cm	<table border="0"> <tr> <td>695.040.051</td> <td>695.040.053</td> <td>695.040.007</td> </tr> <tr> <td>695.042.051</td> <td>695.042.053</td> <td>695.042.007</td> </tr> <tr> <td>695.044.051</td> <td>695.044.053</td> <td>695.044.007</td> </tr> </table>	695.040.051	695.040.053	695.040.007	695.042.051	695.042.053	695.042.007	695.044.051	695.044.053	695.044.007
695.040.051	695.040.053	695.040.007									
695.042.051	695.042.053	695.042.007									
695.044.051	695.044.053	695.044.007									
<p>Structure - Sans fente - sans top Estructura - Sin buzón - sin tapa Structure - Doors without top</p>											

MODÈLE / VARIANTES / VERSIONS	SERRURES / CERRADURA / LOCK TYPES	TYPE / TIPO / TYPE	RÉFÉRENCE / REFERENCIA / CODE
P1 P2 P3 P4 	CLÉ / LLAVE / KEY	P1 P2 P3 P4	1.695.121... 1.695.122... 1.695.123... 1.695.124...
	COMBINAISON / COMBINACIÓN / 4-DIGIT LOCK	P1 P2 P3 P4	1.695.221... 1.695.222... 1.695.223... 1.695.224...
	CARTE RFID / TARJETA RFID / RFID CARD	P1 P2 P3 P4	1.695.321... 1.695.322... 1.695.323... 1.695.324...
	ELECTRONIQUE / ELECTRÓNICA / ELECTRONIC	P1 P2 P3 P4	1.695.421... 1.695.422... 1.695.423... 1.695.424...
<p>Porte sans fente Puertas sin buzón Doors</p>			

# FINITIONS | ACABADOS | FINISHES

## STRUCTURE / ESTRUCTURA / FRAME | PORTE / PUERTA / DOORS

	Argent Plata Silver		Blanc Blanco White		Gris Gris Grey		Hêtre Haya Beech		Chêne Moyen Roble Maple
	Blanc Blanco White		Gris Gris Grey		Noir Negro Black		Jaune Amarillo Yellow		Rouge Rojo Red
	Graphite Grafito Graphite		Vert Verde Green		Bleu Azul Blue				

# MODÈLES | VARIANTES | VERSIONS

## CASIERI MONOCHROMES / TAQUILLA MONOCOLOR / SINGLE-COLOR LOCKERS

MODÈLE / VARIANTES / VERSIONS	SERRURES / CERRADURA / LOCK TYPES	DIMENSIONS / MEDIDAS / MEASUREMENTS	RÉFÉRENCE / REFERENCIA / CODE
 <p><b>Avec fente Con buzón Mail-hole doors</b></p>	CLÉ / LLAVE / KEY	175 cm 133 cm 90,6 cm	695.101.-.- 695.102.-.- 695.103.-.-
	COMBINAISON / COMBINACIÓN / 4-DIGIT LOCK	175 cm 133 cm 90,6 cm	695.201.-.- 695.202.-.- 695.203.-.-
	CARTE RFID / TARJETA RFID / RFID CARD	175 cm 133 cm 90,6 cm	695.301.-.- 695.302.-.- 695.303.-.-
	ELECTRONIQUE / ELECTRÓNICA / ELECTRONIC	175 cm 133 cm 90,6 cm	695.401.-.- 695.402.-.- 695.403.-.-

 <p><b>Avec fente - sans top Con buzón - sin tapa Mail-hole doors without top</b></p>	CLÉ / LLAVE / KEY	175 cm 133 cm 90,6 cm	695.111.-.- 695.112.-.- 695.113.-.-
	COMBINAISON / COMBINACIÓN / 4-DIGIT LOCK	175 cm 133 cm 90,6 cm	695.211.-.- 695.212.-.- 695.213.-.-
	CARTE RFID / TARJETA RFID / RFID CARD	175 cm 133 cm 90,6 cm	695.311.-.- 695.312.-.- 695.313.-.-
	ELECTRONIQUE / ELECTRÓNICA / ELECTRONIC	175 cm 133 cm 90,6 cm	695.411.-.- 695.412.-.- 695.413.-.-

# MODÈLES | VARIANTES | VERSIONS

## CASIERI MONOCHROMES / TAQUILLA MONOCOLOR / SINGLE-COLOR LOCKERS

MODÈLE / VARIANTES / VERSIONS	SERRURES / CERRADURA / LOCK TYPES	DIMENSIONS / MEDIDAS / MEASUREMENTS	RÉFÉRENCE / REFERENCIA / CODE
 <p><b>Sans fente Sin buzón Doors</b></p>	CLÉ / LLAVE / KEY	175 cm 133 cm 90,6 cm	695.121.-.- 695.122.-.- 695.123.-.-
	COMBINAISON / COMBINACIÓN / 4-DIGIT LOCK	175 cm 133 cm 90,6 cm	695.221.-.- 695.222.-.- 695.223.-.-
	CARTE RFID / TARJETA RFID / RFID CARD	175 cm 133 cm 90,6 cm	695.321.-.- 695.322.-.- 695.323.-.-
	ELECTRONIQUE / ELECTRÓNICA / ELECTRONIC	175 cm 133 cm 90,6 cm	695.421.-.- 695.422.-.- 695.423.-.-

 <p><b>Sans fente - sans top Sin buzón - sin tapa Doors without top</b></p>	CLÉ / LLAVE / KEY	175 cm 133 cm 90,6 cm	695.131.-.- 695.132.-.- 695.133.-.-
	COMBINAISON / COMBINACIÓN / 4-DIGIT LOCK	175 cm 133 cm 90,6 cm	695.231.-.- 695.232.-.- 695.233.-.-
	CARTE RFID / TARJETA RFID / RFID CARD	175 cm 133 cm 90,6 cm	695.331.-.- 695.332.-.- 695.333.-.-
	ELECTRONIQUE / ELECTRÓNICA / ELECTRONIC	175 cm 133 cm 90,6 cm	695.431.-.- 695.432.-.- 695.433.-.-





# FINITIONS | ACABADOS | FINISHES

051	Argent Plata Silver	053	Blanc Blanco White	054	Gris Gris Grey	055	Hêtre Haya Beech	061	Chêne Moyen Roble Maple
062	Poirier Peral Pear	116	Wengué Wengue Wengue	103	Acacia Clair Acacia Clara Light Acacia	104	Acacia Foncé Acacia Oscura Dark Acacia	007	Graphite Grafito Graphite
272	Chêne Veiné Castaño Claro Oak	273	Chêne Grisé Castaño Oscuro Dark Oak						

# FINITIONS | ACABADOS | FINISHES

051	Argent Plata Silver	053	Blanc Blanco White	054	Gris Gris Grey	055	Hêtre Haya Beech	061	Chêne Moyen Roble Maple
062	Poirier Peral Pear	116	Wengué Wengue Wengue	103	Acacia Clair Acacia Clara Light Acacia	104	Acacia Foncé Acacia Oscura Dark Acacia	007	Graphite Grafito Graphite
272	Chêne Veiné Castaño Claro Oak	273	Chêne Grisé Castaño Oscuro Dark Oak						

## ICLÉS PASSE-PARTOUT | LLAVES MAESTRAS | MANDATORY MASTER KEY

MODÈLE / VARIANTES / VERSIONS	RÉFÉRENCE / REFERENCIA / CODE
 <p>Clé Llave Key</p>	1.695.766.000
 <p>Combinaison Combinación 4-digit lock</p>	1.695.764.000
 <p>Carte RFID Tarjeta RFID RFID card</p>	1.695.760.000
 <p>Electronique Electrónica Electronic</p>	1.695.762.000

## IMODÈLES | VARIANTES | VERSIONS

MONOCHROMES / MONOCOLOR / SINGLE-COLOR

MODÈLE / VARIANTES / VERSIONS	DIMENSIONS / MEDIDAS / MEASUREMENTS	RÉFÉRENCE / REFERENCIA / CODE
 <p>Armoire penderie Perchero Hanging cabinet</p>	175 cm	695.052.-.-

## IFINITIONS | ACABADOS | FINISHES

051 Argent Plata Silver	053 Blanc Blanco White	054 Gris Gris Grey	055 Hêtre Haya Beech	061 Chêne Moyen Roble Maple
062 Poirier Peral Pear	116 Wengué Wengue Wengue	103 Acacia Clair Acacia Clara Light Acacia	104 Acacia Foncé Acacia Oscura Dark Acacia	007 Graphite Grafito Graphite
272 Chêne Veiné Castaño Claro Oak	273 Chêne Grisé Castaño Oscuro Dark Oak			

## ICOMPLÉMENTS | COMPLEMENTOS | COMPLEMENTS

MODÈLE / VARIANTES / VERSIONS	TYPE / TIPO / TYPE	RÉFÉRENCE / REFERENCIA / CODE
 <p>Tops d'union Tapas de unión Multi-tops</p>	2 Casiers / 2 Taquillas / 2 Lockers 3 Casiers / 3 Taquillas / 3 Lockers 4 Casiers / 4 Taquillas / 4 Lockers 5 Casiers / 5 Taquillas / 5 Lockers 6 Casiers / 6 Taquillas / 6 Lockers	1.695.010.-.- 1.695.008.-.- 1.695.006.-.- 1.695.004.-.- 1.695.002.-.-

## IFINITIONS | ACABADOS | FINISHES

051 Argent Plata Silver	053 Blanc Blanco White	054 Gris Gris Grey	055 Hêtre Haya Beech	061 Chêne Moyen Roble Maple
062 Poirier Peral Pear	116 Wengué Wengue Wengue	103 Acacia Clair Acacia Clara Light Acacia	104 Acacia Foncé Acacia Oscura Dark Acacia	007 Graphite Grafito Graphite
272 Chêne Veiné Castaño Claro Oak	273 Chêne Grisé Castaño Oscuro Dark Oak			

# ORGATOWER

Ces tours d'organisation élargissent la vision des blocs-tiroirs individuels et proposent de nouvelles configurations pour créer des limites visuelles entre les postes de travail.

Las torres de organización extienden la visión de las cajoneras individuales y proponen nuevas configuraciones con las que crear límites visuales entre puestos de trabajo.

The orgatower creates visual boundaries between workstations and therefore certain privacy being in the same office space. At the same time it provides a voluminous and close-at-hand storage space for files, documents, and other items.



## MODULE / MÓDULO / STORAGE

Mélamine / Melamina / Melamine: 25 mm

## FINITION STRUCTURE / ACABADO ESTRUCTURA / FRAME FINISH

Mélamine  
Melamina  
Melamine

## HAUTEUR / ALTURA / HEIGHT

Fixe:  
Fija: 130, 73 cm  
Fixed:



CHÂSSIS  
TÉLESCOPIQUE

ARCHIVO  
TELESCÓPICO

TELESCOPIC  
FILES

| HAUTEUR 130 CM INDIVIDUEL  
| ALTURA 130 CM INDIVIDUAL  
| HEIGHT 130 CM SINGLE FACE

Glissières à roulements à billes et 1 tirette plumier incluse.  
Con guías metálicas y 1 cajón plumier incluido.  
Sliding guides and 1 pencil drawer included.



| HAUTEUR 130 CM INDIVIDUEL  
| ALTURA 130 CM INDIVIDUAL  
| HEIGHT 130 CM SINGLE FACE

Glissières à roulements à billes, 1 tirette plumier et 1 châssis télescopique inclus.  
Con guías metálicas, 1 cajón plumier y 1 archivo telescópico.  
Sliding guides, 1 pencil drawer and 1 telescopic file included.



| HAUTEUR 130 CM DOUBLE  
| ALTURA 130 CM DOBLE  
| HEIGHT 130 CM DOUBLE

Glissières à roulements à billes et 2 tirettes plumier incluses.  
Con guías metálicas y 2 cajones plumier incluidos.  
Sliding guides and 2 pencil drawers included.



| HAUTEUR 130 CM DOUBLE  
| ALTURA 130 CM DOBLE  
| HEIGHT 130 CM DOUBLE

Glissières à roulements à billes, 2 tirettes plumier et 1 châssis télescopique inclus.  
Con guías metálicas, 2 cajones plumier y 1 archivo telescópico.  
Sliding guides, 2 pencil drawers and 1 telescopic file included.





| HAUTEUR BUREAU - INDIVIDUEL  
| ALTURA MESA INDIVIDUAL  
| DESK HIGH - SINGLE FACE

Glissières à roulements à billes et 1 tirette plumier incluse.  
Con guías metálicas y 1 cajón plumier incluido.  
Sliding guides and 1 pencil drawer included.







| HAUTEUR BUREAU - INDIVIDUEL  
| ALTURA MESA INDIVIDUAL  
| DESK HIGH - SINGLE FACE

Glissières à roulements à billes, 1 tirette plumier et 1 châssis télescopique inclus.  
Con guías metálicas, 1 cajón plumier y 1 archivo telescópico.  
Sliding guides, 1 pencil drawer and 1 telescopic file included.



# MODÈLES | VARIANTES | VERSIONS

ORGATOWER H.130 / ORGATOWER H.130 / ORGATOWER H.130

MODÈLE / VARIANTES / VERSIONS	TYPE / TIPO / TYPE	DIMENSIONS / MEDIDAS / MEASUREMENTS	RÉFÉRENCE / REFERENCIA / CODE
	Droite / Derecha / Right	80,3 x 45,3 x 130 cm	361.001... - -
Hauteur 130 cm individuel Altura 130 cm individual Height 130 cm single face	Glissières à roulements à billes et 1 tirette plumier incluse / Con guías metálicas y 1 cajón plumier incluido / Sliding guides and 1 pencil drawer included		
	Gauche / Izquierda / Left		361.002... - -
	Droite / Derecha / Right	80,3 x 45,3 x 130 cm	361.003... - -
Hauteur 130 cm individuel Altura 130 cm individual Height 130 cm single face	Glissières à roulements à billes, 1 tirette plumier et 1 châssis télescopique inclus / Con guías metálicas, 1 cajón plumier incluido y 1 archivo telescópico / Sliding guides, 1 pencil drawer and 1 telescopic file included		
	Gauche / Izquierda / Left		361.011... - -
	Droite / Derecha / Right	80,3 x 45,3 x 130 cm	361.012... - -
Hauteur 130 cm double Altura 130 cm doble Height 130 cm double	Glissières à roulements à billes et 2 tirettes plumier incluses / Con guías metálicas y 2 cajones plumier incluidos / Sliding guides and 2 pencil drawers included		
	Gauche / Izquierda / Left		361.013... - -
	Droite / Derecha / Right	80,3 x 45,3 x 130 cm	361.013... - -
Hauteur 130 cm double Altura 130 cm doble Height 130 cm double	Glissières à roulements à billes, 2 tirettes plumier et 1 châssis télescopique inclus / Con guías metálicas, 2 cajones plumier incluidos y 1 archivo telescópico / Sliding guides, 2 pencil drawers and 1 telescopic file included		

# MODÈLES | VARIANTES | VERSIONS

ORGATOWER - HAUTEUR BUREAU / ORGATOWER - ALTURA MESA / ORGATOWER - DESK HIGH

MODÈLE / VARIANTES / VERSIONS	TYPE / TIPO / TYPE	DIMENSIONS / MEDIDAS / MEASUREMENTS	RÉFÉRENCE / REFERENCIA / CODE
	Droite / Derecha / Right	80,3 x 45,3 x 73 cm	361.004... - -
Hauteur bureau - Caisson Altura mesa individual Desk high - Single desk	Glissières à roulements à billes et 1 tirette plumier incluse / Con guías metálicas y 1 cajón plumier incluido / Sliding guides and 1 pencil drawer included		
	Gauche / Izquierda / Left		361.005... - -
	Droite / Derecha / Right	80,3 x 45,3 x 73 cm	361.014... - -
Hauteur bureau - Caisson Altura mesa individual Desk high - Single desk	Glissières à roulements à billes, 1 tirette plumier et 1 châssis télescopique inclus / Con guías metálicas, 1 cajón plumier incluido y 1 archivo telescópico / Sliding guides, 1 pencil drawer and 1 telescopic file included		
	Gauche / Izquierda / Left		361.015... - -

# FINITIONS | ACABADOS | FINISHES

DESSOUS, JOUES ET FOND  
BAJO, LATERALES Y TRASERA  
BOTTOM, SIDE AND BACK PANELS

TOP ET FAÇADES  
SOBRE Y DELANTERA  
TOP AND FRONT

Argent Plata Silver	051	Argent Plata Silver	053	Blanc Blanco White	054	Gris Gris Grey	055	Hêtre Haya Beech	061	Chêne Moyen Roble Maple
	062	Poirier Peral Pear	116	Wengué Wengue Wengue	694	Acacia Clair Acacia Clara Light Acacia	695	Acacia Foncé Acacia Oscura Dark Acacia	125	Graphite Grafito Graphite
	272	Chêne Veiné Castaño Claro Oak	273	Chêne Grisê Castaño Oscuro Dark Oak						
Blanc Blanco White	088	Argent Plata Silver	081	Blanc Blanco White	076	Gris Gris Grey	077	Hêtre Haya Beech	078	Chêne Moyen Roble Maple
	079	Poirier Peral Pear	080	Wengué Wengue Wengue	168	Acacia Clair Acacia Clara Light Acacia	169	Acacia Foncé Acacia Oscura Dark Acacia	115	Graphite Grafito Graphite
	043	Chêne Veiné Castaño Claro Oak	106	Chêne Grisê Castaño Oscuro Dark Oak						
Graphite Grafito Graphite	228	Argent Plata Silver	229	Blanc Blanco White	230	Gris Gris Grey	231	Hêtre Haya Beech	232	Chêne Moyen Roble Maple
	234	Poirier Peral Pear	700	Acacia Clair Acacia Clara Light Acacia	701	Acacia Foncé Acacia Oscura Dark Acacia	204	Graphite Grafito Graphite	251	Chêne Veiné Castaño Claro Oak
	252	Chêne Grisê Castaño Oscuro Dark Oak								
Monochrome Monocolor Single-colour	197	Gris Gris Grey	198	Hêtre Haya Beech	199	Chêne Moyen Roble Maple	200	Poirier Peral Pear	202	Wengué Wengue Wengue
	103	Acacia Clair Acacia Clara Light Acacia	104	Acacia Foncé Acacia Oscura Dark Acacia	209	Chêne Veiné Castaño Claro Oak	235	Chêne Grisê Castaño Oscuro Dark Oak		



# TISSUS TAPIZADOS UPHOLSTERY

Les procédés d'impression ne permettent pas une reproduction exacte des tonalités originales. Pour plus de fiabilité, veuillez consulter le nuancier tissu.

Los procedimientos de impresión no permiten una reproducción exacta de las tonalidades originales. Para una máxima fiabilidad consultar el catálogo de telas.

Printing procedures do not provide an exact reproduction of original colour tones. Please check the fabric sample book.

Série 1 / Serie 1 / Serie 1

ONE



Série 1 / Serie 1 / Serie 1

PUMA



Série 1 / Serie 1 / Serie 1

ARAN



Série 1 / Serie 1 / Serie 1



Série 1 / Serie 1 / Serie 1



Série 1 / Serie 1 / Serie 1



Série 1 / Serie 1 / Serie 1



Série 1 / Serie 1 / Serie 1



Série 4 / Serie 4 / Serie 4



Série 4 / Serie 4 / Serie 4



**DANZICA**

DA054

DA008

DA063

DA034

DA041

DA046

DA048

DA042

DA064

DA023

Série 4 / Serie 4 / Serie 4



**GRAVITY**

GRA21

GRA12

GRA25

GRA01

GRA28

GRA29

GRA07

GRA17

GRA31

Série 4 / Serie 4 / Serie 4



**RAM**

RAM32

RAM49

RAM34

RAM41

RAM19

RAM75

RAM74

RAM67

RAM03

RAM35

Série 4 / Serie 4 / Serie 4



**SILVERTEX**

S0002

S4024

S0013

S2012

S2064

S5008

S3001

S4001

S4003

S9003

Série 4 / Serie 4 / Serie 4



**EVOLVE**

EVO00

EVO77

EVO21

EVO28

EVO90

Série 7 / Serie 7 / Serie 7



**PIEL**

P.179

P.129

P.102

P.115

P.103

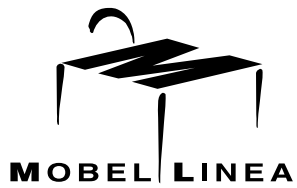

Mobel Linea, S.L. se réserve le droit de modifier les caractéristiques techniques des produits sans préavis en les adaptant au progrès technique. Les procédés d'impression ne permettent pas une reproduction exacte des tonalités originales. Pour plus de fiabilité, veuillez consulter le nuancier finitions. Textes, photos et illustrations non contractuels. / Mobel Linea, S.L. se reserva el derecho a introducir en estos productos sin previo aviso, las mejoras técnicas derivadas de su constante investigación. Los procedimientos de impresión no permiten una reproducción exacta de las tonalidades originales. Para una máxima fiabilidad consultar los catálogos de acabados. / Mobel Linea, S.L. reserves all rights to make technical changes and improvements at any time resulting from his ongoing research, without previous notice. Please bear in mind the actual finish may be slightly different. Since the printing does not show 100% the real colors. To make sure please look at

# CATALOGUE GÉNÉRAL CATÁLOGO GENERAL MAIN CATALOGUE

Sièges  
Sillería  
Seating





# ENTERPRISE EMPRESA BUSINESS

---

**MOBEL LINEA, S.L.** est une entreprise familiale fondée en 1973 et située à Cervera (Lleida), Espagne.

Depuis le début, comme fabricants de mobilier de bureau, notre objectif a été de proposer des solutions simples, fonctionnelles, innovantes et de qualité pour transformer les espaces de travail en écosystèmes de productivité, de coexistence et de confort. La motivation constante à nous rapprocher des gens a eu un impact positif sur notre façon de travailler et de nous organiser en appliquant de nouvelles méthodologies et processus.

Au fil des années, nous avons acquis une notoriété dans le secteur et nous nous sommes imposés comme l'un des principaux fabricants de mobilier de bureau au niveau national et européen.

Malgré l'équipe de 280 personnes, nous continuons à garder vivante notre essence familiale.

**MOBEL LÍNEA, S.L.** somos una empresa familiar fundada en el año 1973 y situada en Cervera, provincia de Lérida (España).

Somos fabricantes de mobiliario de oficina, y desde los inicios, nuestro propósito ha sido ofrecer soluciones sencillas, funcionales, innovadoras y de calidad para transformar los espacios de trabajo en ecosistemas de productividad, convivencia y confort. Nuestra motivación constante por acercarnos a las personas ha impactado de forma positiva en nuestra forma de trabajar y de organizarnos aplicando nuevas metodologías y procesos.

Con el paso de los años hemos ido ganando notoriedad en el sector y nos hemos consolidado como uno de los fabricantes de muebles de oficina líder a nivel nacional y Europeo.

A pesar de contar con un total de 280 trabajadores, seguimos manteniendo viva nuestra esencia familiar.

**MOBEL LINEA, S.L.** is a family run business founded in 1973 and located in Cervera (Lleida), Spain.

As manufacturer of office furniture and seating, from the beginning, the aim has been to offer functional, innovative, and quality solutions to transform offices into spaces of productivity, collaboration, and well-being. The focus on people has a positive impact on the way Mobel Linea sees the future of working and organizing by applying new methodologies and processes.

Over the years the company has grown into an important player in the office furniture industry in Western Europe.

With a total of over 280 workers, Mobel Linea still maintains the family essence alive.



# RESSOURCES RECURSOS RESOURCES

Nos installations, comme l'équipe humaine de notre usine, se sont développées progressivement, en s'adaptant aux demandes et besoins du marché. En 1995, la production de l'usine a été divisée en deux entrepôts, l'un pour bois et l'autre pour le métal:

- MOBEL I: Entrepôt principal, d'une surface de 45.000 m<sup>2</sup>, destiné à la fabrication de mobilier et sièges.
- MOBEL III: situé dans la zone industrielle et d'une surface de 13.000 m<sup>2</sup>, il est destiné à la fabrication de composants, structures et armoires métalliques.

Notre production est gérée par une unité logistique novatrice depuis la création d'un entrepôt en 2004 entièrement automatisé et auto-portant avec une capacité de 33.000 europalettes. D'une hauteur de 41 mètres ce entrepôt est un point de référence sur le territoire.

Déjà en 2011, création d'une annexe de l'autre usine située dans la zone industrielle pour la fabrication des armoires métalliques. À cette époque, nous avons profité de l'intervention pour remplacer le tunnel de peinture par un tunnel beaucoup plus performant et écoresponsable.

Actuellement, nous nous engageons à accroître notre capacité de production en investissant dans une nouvelle ligne de fabrication de 2.000 m<sup>2</sup> avec laquelle nous atteindrons une plus grande capacité de production, une meilleure automatisation, une meilleure qualité de nos produits ainsi qu'une considérable réduction de la consommation énergétique.

Nuestras instalaciones, al igual que el equipo humano, han ido creciendo de forma progresiva adaptándose a las demandas del mercado. En 1995 se dividió la producción de la fábrica en dos naves, una para la madera y otra para el metal:

- MOBEL I: Nave principal, con una superficie de 45.000 m<sup>2</sup>, destinada a la producción de mobiliario de madera y sillería.
- MOBEL III: ubicada en el polígono industrial y con una superficie de 13.000 m<sup>2</sup> está destinada a la fabricación de estructuras y muebles metálicos.

En 2004 construimos un almacén automatizado que supuso la trazabilidad absoluta de la producción de la fábrica. El almacén destaca por su dimensiones, 41 metros de altura y una capacidad de hasta 33.000 europalets, y lo convierte en un punto de referencia en el territorio.

Ya en 2011, ampliamos la nave situada en el polígono industrial con el fin de fabricar armoires metálicos. En ese momento, aprovechamos la intervención para sustituir el túnel de pintura por otro mucho más eficiente y responsable con el Medio Ambiente.

En la actualidad, apostamos por ampliar nuestra capacidad productiva invirtiendo en un nuevo tren de producción de 2.000 m<sup>2</sup> con el que lograremos: mayor capacidad de producción, mayor automatización entre procesos, mayor calidad en nuestros productos y menor consumo energético.

Mobel Linea has been growing progressively, adapting to market demands. In 1995 the factory opened a second facility for metal production, so nowadays Mobel Linea's production takes place in:

- MOBEL I: Main facilities, with an area of 45,000 m<sup>2</sup>, headquarters and where production of wooden furniture and chairs finds place.
- MOBEL III: located in the nearby industrial estate, with 13,000 m<sup>2</sup>, is the place for the manufacture of metal cabinets, frames, and other metal parts.

In 2004 an all-automated warehouse was built for raw materials, stocks, and finished products. The warehouse stands out for its big dimensions, is 41 meters high and has a capacity of up to 33,000 Euro pallets, making it a point of reference in the landscape of Cervera.

In 2011, MOBEL III expanded to produce metal cabinets and the installation of a brand-new painting tunnel meeting the latest requirements in terms of efficiency and the environment.

This year, we invested in a new 2,000 m<sup>2</sup> production plant with which we are achieving: higher production capacity, better automation between processes, lower energy consumption and improving product quality.

CROISSANCE CONSTANTE

CRECIENDO DE FORMA  
CONSTANTE

STEADY GROWTH





# QUALITÉ CALIDAD QUALITY

La satisfaction client est inscrite dans notre ADN, c'est pourquoi nous veillons jour après jour à la qualité de tous nos produits.

Depuis 2001, nous sommes certifiés conformément aux normes de gestion de la qualité établies dans la norme **ISO 9001**. Essentiellement, avec cette norme, nous garantissons que tous les processus visent l'efficacité du système de gestion et l'assurance qualité de nos produits et services. De plus, le lien implicite entre **ISO 9001**, **ISO 14001**, **ISO 14006** et PEFC nous permet de réaliser un système de management intégré axé sur le management environnemental.

Nos produits sont de haute qualité et ils bénéficient du tampon qualité contrôlée après avoir été soumis à des tests rigoureux de sécurité et de durabilité par le laboratoire de l'institut technologique du meuble, bois, emballages et autres, **AIDIMME**.

La satisfacción de los clientes está inscrita en nuestro ADN, por eso velamos día tras día por la calidad de todos nuestros productos.

Desde el año 2001 estamos certificados de acuerdo con los estándares de gestión de calidad establecidos en la norma **ISO 9001**. En esencia, con esta norma, garantizamos que todos los procesos están orientados a la eficacia del sistema de gestión y al aseguramiento de la calidad de nuestros productos y servicios. Adicionalmente, la vinculación implícita entre la **ISO 9001**, la **ISO 14001**, la **ISO 14006** y el PEFC nos permite llevar a cabo un sistema de gestión integrado incidiendo en la gestión ambiental.

Fabricamos productos de alta calidad y por eso nuestros muebles llevan el sello de calidad tras ser sometidos a rigurosas pruebas de seguridad y durabilidad en el laboratorio **AIDIMME**, Instituto Tecnológico Metalmeccánico, Mueble, Madera, Embalaje y Afines.

Customer satisfaction is very important for Mobel Linea, which is why the quality of all the products are ensured day after day.

Since 2001 Mobel Linea has been certified in accordance with the quality management standards established in the **ISO 9001** standard. In essence, with this standard, it guarantees that all processes are aimed at the effectiveness of the management system and the quality assurance of their products and services. Additionally, the implicit link between **ISO 9001**, **ISO 14001**, **ISO 14006** and PEFC allows to carry out an integrated management system focusing on environmental management.

Manufacturing high-quality products and is why the furniture bears the seal of quality after being subjected to rigorous safety and durability tests in the **AIDIMME** laboratory, Technological Institute for Metalworking, Furniture, Wood, Packaging and Related.

# RÉSEAU COMMERCIAL RED COMERCIAL COMMERCIAL NETWORK

Grâce à notre réseau commercial de revendeurs, **MOBEL LINEA**, S.L. est présente dans différents pays du monde. Nos principaux marchés sont concentrés principalement en Europe (France, Allemagne, Royaume-Uni, la Suisse, la Belgique, la Hollande, Bulgarie, Portugal, Grèce, etc.), mais nous avons également des points stratégiques hors d'Europe (Émirats Arabes, Arabie Saoudite, Qatar, Costa Rica, etc.).

Grâce à notre flotte de 35 camions et 18 remorques, nous sommes en mesure de réaliser des livraisons à tous nos clients européens, garantissant ainsi les délais de livraison demandés et permettant même de les réduire en cas d'extrême priorité.

En plus de nos camions, nous utilisons le transport maritime pour le commerce international par le biais de containers ou groupages, travaillant avec les principales entreprises d'affrètement et obtenant un maximum de garantie de fiabilité, qualité et sécurité de la bonne arrivée de nos produits à destination.

Gracias a nuestra red comercial de representantes y distribuidores, **MOBEL LINEA**, S.L. está presente en distintos países del mundo. Nuestro nicho de mercado se concentra, en su mayoría, en Europa (Francia, Alemania, Reino Unido, Suiza, Bélgica, Bulgaria, Portugal, Grecia, etc.), pero también tenemos puntos estratégicos fuera de Europa (Emiratos Árabes, Arabia Saudí, Qatar, Costa Rica, etc.).

Disponemos de una flota de 35 camiones y 18 remolques, con los que garantizamos las entregas a todos nuestros clientes europeos, cumpliendo con los plazos de entrega exigidos e incluso reduciéndose en casos de extrema prioridad.

Además de nuestros camiones, para el Comercio Internacional, utilizamos el transporte marítimo, con contenedores o grupajes, trabajando con las principales compañías navieras del mercado y obteniendo las máximas garantías de fiabilidad, calidad y seguridad en la llegada de nuestros productos a destino.

Thanks to a network of representatives and distributors, **MOBEL LINEA**, S.L. is present in numerous countries around the world. The main market is in Western Europe (France, Portugal, Belgium, The Netherlands, United Kingdom, Germany and Switzerland), but also sells in Eastern Europe, the Middle East, South America and several African Countries.

Mobel Linea has its own fleet of 35 trucks to deliver European customers, being able to guarantee fast deliveries and reduce product-damage due to transport.

For overseas deliveries Mobel Linea works with well-known shipping companies to obtain the maximum guarantees of reliability, quality and safety in the transport of the products.



GARANTIE DE QUALITÉ  
ET SATISFACTION

ASEGURAMOS CALIDAD Y  
SATISFACCIÓN

QUALITY AND SATISFACTION  
GUARANTEE

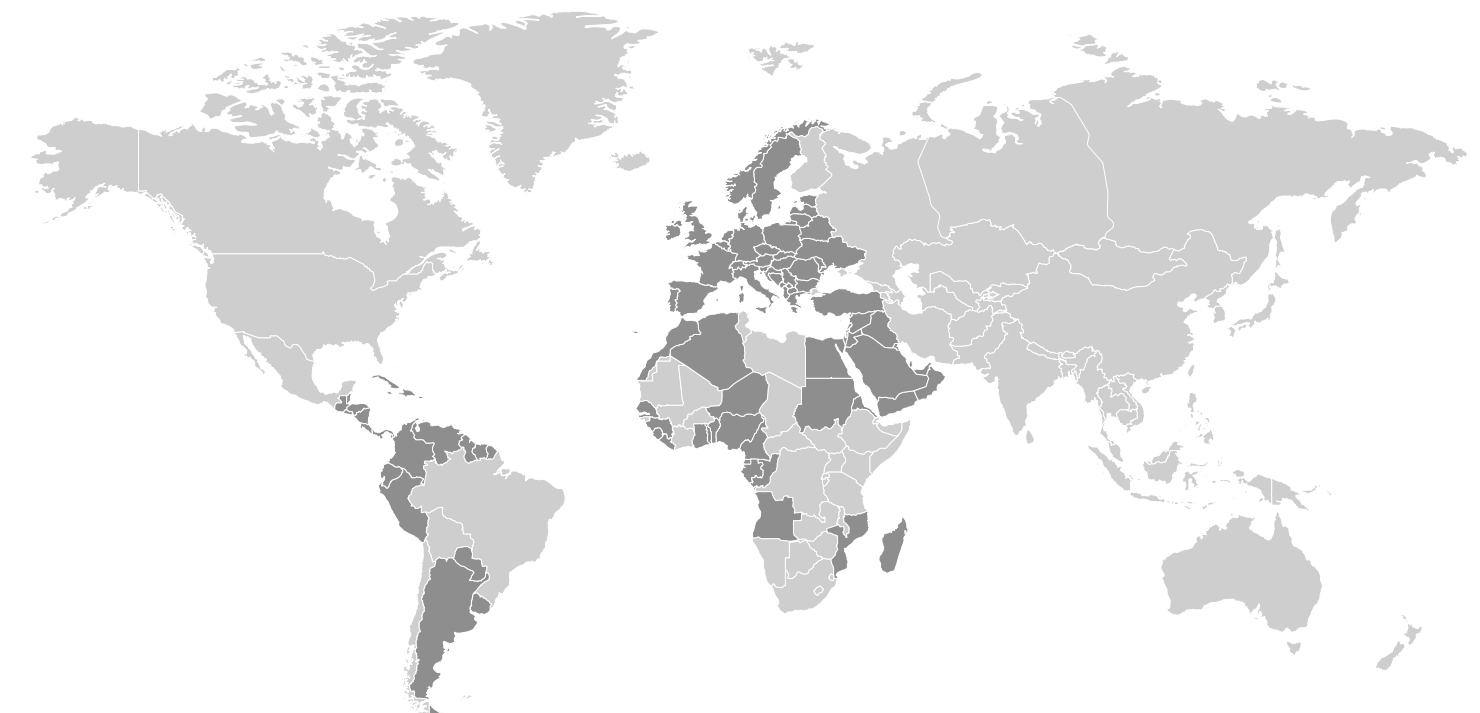

Zones d'implantations **MOBEL LINEA**.  
Zonas donde actualmente está presente **MOBEL LINEA**, S.L.  
States with **MOBEL LINEA**, S.L. Partners.

# INVESTISSEMENT ET DÉVELOPPEMENT

## INVESTIGACIÓN Y DESARROLLO

### RESEARCH AND DEVELOPMENT

En tant que concepteurs-designers et fabricants de mobilier de bureau, nous répondons aux besoins du marché en apportant valeur et professionnalisme. Nous créons des produits axés sur les besoins des gens. Nous analysons leur comportement en tenant compte de l'évolution technologique et des méthodologies de travail afin de le transformer en bureau.

Dans le processus de conception et de développement, nous sommes soutenus et guidés par les prémisses de l'**Écodesign**, réduisant l'impact environnemental de nos produits tout au long de leur cycle de vie en appliquant différentes stratégies:

- Utilisation de matériaux recyclables.
- Bois issu de sources durables: certification **PEFC**.
- Réduire l'impact environnemental du transport et des déchets d'emballage générés.
- Garantir le moindre impact environnemental lors de l'utilisation.
- Tenir compte du tri et de la haute recyclabilité des composants en fin de vie.

Notre proposition de valeur se concentre sur l'intemporalité du design, offrant fonctionnalité, confort et durabilité à nos clients. Le temps et la confiance nous motivent à avancer et à continuer à apporter de l'expérience et de l'innovation.

Como diseñadores y fabricantes de mobiliario de oficina atendemos a las necesidades del mercado aportando valor y profesionalidad. Creamos productos poniendo el foco en las necesidades de las personas. Analizamos sus comportamientos fijándonos en la evolución tecnológica y las metodologías de trabajo para detectar oportunidades y transformar su experiencia en la oficina.

En el proceso de concepción y desarrollo nos apoyamos y guiamos por las premisas del **Ecodiseño**, reduciendo el impacto ambiental de nuestros productos a lo largo de su ciclo de vida aplicando diferentes estrategias:

- Uso de materiales reciclables.
- Madera procedente de fuentes sostenibles: certificación **PEFC**.
- Reducir el impacto ambiental del transporte y de los residuos generados de embalajes.
- Asegurar el menor impacto ambiental durante el uso.
- Tener en cuenta la separación y la alta reciclabilidad de los componentes al final de su vida útil.

Nuestra propuesta de valor se centra en la atemporalidad del diseño aportando funcionalidad, comodidad y durabilidad a nuestros clientes. El tiempo y la confianza han estimulado nuestras ganas y nuestra motivación para seguir escalando peldaños en el mercado brindando experiencia e innovación.

As designers and manufacturers of office furniture, the needs of the market are served, providing value and professionalism, and always focusing on the needs of people. Analysing their behaviour by looking at technological evolution and work methodologies to detect opportunities and so transform the people's experience in the office.

In the process of conception and development, supporting and guiding by the premises of **Eco-design**, reducing the environmental impact of all the products throughout their life cycle by applying different strategies:

- Use of recyclable materials.
- Wood from sustainable sources: **PEFC** certification.
- Reduce the environmental impact of transport and packaging waste generated.
- Ensure the least environmental impact during use.
- Consider the separation and high recyclability of the components at the end of their useful life.

Mobel Linea's value proposition focus on the timelessness of design, providing functionality, comfort, and durability to the customers. Time and trust have stimulated Mobel Linea's desire and motivation to continue climbing steps in the market, providing experience and innovation.

| ÉCOCONCEPTION

| ECODISEÑO

| ECODESIGN

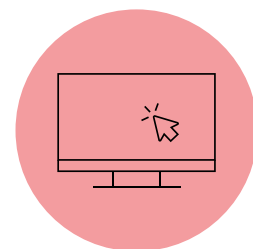

RECHERCHE  
INVESTIGACIÓN  
RESEARCH



DÉVELOPPEMENT  
DESARROLLO  
DEVELOPMENT

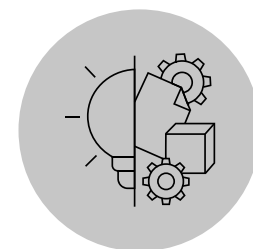

INNOVATION  
INNOVACIÓN  
INNOVATION



# ENVIRONNEMENT MEDIO AMBIENTE ENVIRONMENT

Notre engagement envers l'environnement est rigoureux et transparent. Chez Mobel Linea nous appliquons un système de gestion durable aux produits et aux installations qui est essentiel pour réduire l'impact environnemental. La durabilité et l'environnement représentent une responsabilité pour chacun.

En 2005, nous avons intégré la norme **ISO 14001** en Systèmes de Gestion Environnementale qui nous certifie en tant qu'entreprise respectueuse de l'environnement et garantit un travail actif dans l'amélioration continue de nos processus de fabrication.

Notre principale matière première est l'aggloméré de particules en bois avec un traitement spécial superficiel de résines mélaminiques. La certification **PEFC** atteste de notre engagement avec l'Environnement.

La gestion durable commence dès la conception du produit. Pour cette raison, depuis 2013, chez MOBEL LINEA nous avons mis en place la norme **ISO 14006** qui permet d'intégrer un Système de Gestion Environnementale d'**Ecodesign**. Ainsi, lorsque nous concevons un nouveau produit, nous considérons l'impact environnemental qu'il peut avoir dans toutes les phases de son cycle de vie et nous essayons de le réduire sans altérer la qualité de ce produit.

Nuestro compromiso con el medio ambiente es riguroso y transparente. En Mobel Linea aplicamos un sistema de gestión sostenible a los productos e instalaciones que es esencial para reducir el impacto ambiental. La sostenibilidad y el medio ambiente representan una responsabilidad para todos.

En 2005 integramos la normativa **ISO 14001** en Sistemas de Gestión Ambiental que nos certifica como empresa respetuosa con el medio ambiente y garantiza el trabajo activo en mejora continua de nuestros procesos de fabricación.

Una de nuestras materias primas es el aglomerado de partículas de madera con un tratamiento superficial de resinas melamínicas. La certificación **PEFC** que recibe el producto certifica nuestro compromiso con el Medio Ambiente.

La gestión sostenible empieza en el diseño. Por eso, desde el año 2013, en Mobel Linea implementamos la norma **ISO 14006** que permite implantar un sistema de gestión ambiental de **Ecodiseño**. Así pues, cuando proyectamos un nuevo producto contemplamos el impacto ambiental que puede tener en todas las fases de su ciclo de vida y tratamos de reducirlo sin afectar la calidad de dicho producto.

Commitment to the environment is rigorous and transparent. Mobel Linea applies a sustainable management system that is essential to reduce the environmental impact. Sustainability and the environment represent a responsibility for everyone.

Since 2005 the **ISO 14001** standard certifies Mobel Linea as a company that respects the environment and guarantees active work in continuous improvement of its manufacturing processes.

One of the raw materials is the agglomerate of wood particles with a surface treatment of melamine resins. The **PEFC** certification of this raw material certifies the commitment to the Environment.

Sustainable management begins in the design. For this reason, since 2013, Mobel Linea implements the **ISO 14006** standard that allows an **Eco-design** environmental management system. Thus, when a new product is designed, the environmental impact that it may have in all phases of its life cycle is considered and reduced without affecting the quality of the product.

## | DURABILITÉ | SOSTENIBILIDAD | SUSTAINABILITY

**Matériaux recyclables.**  
Materiales reciclables.  
Recyclable materials.

**Optimisation des emballages.**  
Optimización de embalaje.  
Packaging optimization.

**Bois issu de sources durables.**  
Madera de fuentes sostenibles.  
Wood from sustainable sources.

**Recyclabilité en fin de vie utile.**  
Reciclabilidad al final de vida útil.  
Recyclability at the end of its useful life.

**PEFC**  
PEFC/14-35-00142

SIÈGES  
SILLERÍA  
SEATING

INDEX

FAMILLES SIÈGES  
FAMILIAS DE SILLAS  
CHAIR FAMILIES 016

SIÈGE OPÉRATIF 24H  
OPERATIVA 24h  
24H TASK CHAIR 044

SIÈGES OPÉRATIFS  
OPERATIVAS  
TASK CHAIRS 052

SIÈGES DIRECTION  
DIRECCIÓN  
EXECUTIVE 144

CONTRACT  
CONTRACT  
CONTRACT 194

COLLECTIVITÉS  
AUXILIARES  
VISITOR 260

TABOURETS  
TABURETES  
STOOLS 350

POUTRES  
BANCADAS  
BEAMS 366

MOBILIER D'AMPHITHÉÂTRE  
PUPITRES  
CLASSROOM BENCH 392

SOFT SEATING  
SOFT SEATING  
SOFT SEATING 410



FINITIONS  
Acabados  
Finishes

508 | TISSU / TAPIZADOS / UPHOLSTERY

FAMILLES SIÈGES  
FAMILIAS DE SILLAS  
CHAIRS FAMILIES



018 | LED



030 | BROS

# Led

La famille de sièges LED est la plus complète de notre catalogue. Sièges de direction, opératifs et visiteurs disponibles en plusieurs finitions et sur différents types de structure.

La familia de sillas LED es la más completa del catálogo. Abarca desde sillas de dirección con cabezal, sillas operativas con respaldos en distintos acabados hasta sillas de visita con todo tipos de estructura.

LED chairs range is the most complete of our catalogue. Executive chairs with headrest, office chairs with different backrest finishes and visitor chairs with any kind of frame.

SIÈGE  
DIRECTION

SILLA  
DIRECCIÓN

EXECUTIVE  
CHAIR

Tête réglable  
Regulación cabezal  
Headrest adjustment



Réglable en hauteur  
Regulación altura  
Height adjustment

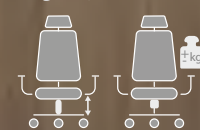

Support lombaire réglable  
Regulación lumbar  
Lumbar support adjustment

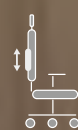

Accoudoirs réglables  
Regulación brazos  
Arms adjustment

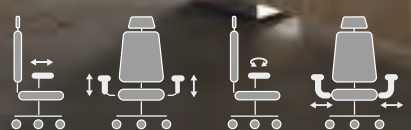

Assise réglable en profondeur  
Asiento regulable en profundidad  
Seat depth adjustment

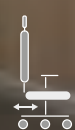

Mécanisme synchrone  
Mecanismo sincro  
Synchro mechanism



| SIÈGE OPÉRATIF

| OPERATIVA

| TASK CHAIR



Siège avec accoudoirs réglables ou sans accoudoirs.  
Se puede escoger sin brazos o con brazos regulables.  
With or without adjustable arms.

Réglable en hauteur  
Regulación altura  
Height adjustment

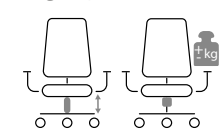

Support lombaire réglable  
Regulación lumbar  
Lumbar support adjustment

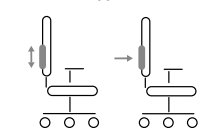

Accoudoirs réglables  
Regulación brazos  
Arms adjustment

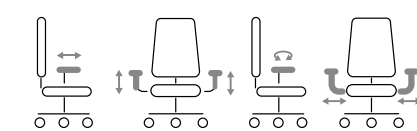

Assise réglable en profondeur  
Asiento regulable en profundidad  
Seat depth adjustment

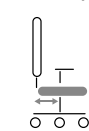

Mécanisme synchrone  
Mecanismo síncro  
Synchro mechanism

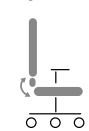

GIRATOIRE  
SUR PATINS

GIRATORIA  
CON TOPES

SWIVEL  
CHAIR



Base chromée ou noire.  
La base puede ser  
cromada o negra.  
Black or chrome swivel  
frame.

Réglable en hauteur  
Regulación altura  
Height adjustment

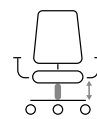



Empilable  
Apilable  
Stackable



| VISITEUR  
| 4 PIEDS

| SILLA  
| DE 4 PATAS

| 4 LEGS  
| CHAIR

Disponible avec ou sans tablette écrite.  
Puede tener la pala escribanía  
como complemento.  
Writing tablet is available as a  
complement.



| VISITEUR  
| LUGE

| CONFIDENTE  
| BALANCÍN

| CANTILEVER  
| CHAIR



Structure argentée, chromée ou noire.  
La estructura puede ser plata, cromada o negra.  
Silver, chrome or black frame.

# IMODÈLES | VARIANTES | VERSIONS

MODÈLE / VARIANTES / VERSIONS	TYPE / TIPO / TYPE	RÉFÉRENCE / REFERENCIA / CODE									
 <p>Direction avec translation d'assise Dirección con traslo Executive with seat depth adjustment</p>	Accoudoirs réglables / Brazos regulables / Adjustable arms	<table border="1"> <tr> <td>Base</td> <td>■</td> <td>■</td> </tr> <tr> <td>Base</td> <td>■</td> <td>■</td> </tr> <tr> <td>Base</td> <td>■</td> <td>■</td> </tr> </table> <p>67.309-... 67.309-...</p>	Base	■	■	Base	■	■	Base	■	■
Base	■	■									
Base	■	■									
Base	■	■									
<p><b>FINITIONS ACABADOS FINISHES</b></p>											
TYPE A / TIPO A / TYPE A		111 118									
TYPE G / TIPO G / TYPE G		321 328									

 <p>Opératifs Operativa Task</p>	Sans accoudoirs / Sin brazos / Without arms	<table border="1"> <tr> <td>Base</td> <td>■</td> <td>■</td> </tr> <tr> <td>Base</td> <td>■</td> <td>■</td> </tr> <tr> <td>Base</td> <td>■</td> <td>■</td> </tr> </table> <p>67.301-... 67.301-...</p>	Base	■	■	Base	■	■	Base	■	■
Base	■	■									
Base	■	■									
Base	■	■									
Accoudoirs réglables / Brazos regulables / Adjustable arms		67.303-... 67.303-...									
<p><b>FINITIONS ACABADOS FINISHES</b></p>											
TYPE A / TIPO A / TYPE A		111 118									
TYPE G / TIPO G / TYPE G		321 328									

 <p>Giratoire Giratoria Swivel</p>	Sans accoudoirs / Sin brazos / Without arms	<table border="1"> <tr> <td>Base + Structure</td> <td>■</td> <td>■</td> <td>■</td> </tr> <tr> <td>Base + Estructura</td> <td>■</td> <td>■</td> <td>■</td> </tr> <tr> <td>Base + Frame</td> <td>■</td> <td>■</td> <td>■</td> </tr> </table> <p>67.111-... 67.111-... 67.111-...</p>	Base + Structure	■	■	■	Base + Estructura	■	■	■	Base + Frame	■	■	■
Base + Structure	■	■	■											
Base + Estructura	■	■	■											
Base + Frame	■	■	■											
Accoudoirs fixes / Con brazos / Fixed arms		67.112-... 67.112-... 67.112-...												
<p><b>FINITIONS ACABADOS FINISHES</b></p>														
TYPE A / TIPO A / TYPE A		102 103 104												
TYPE G / TIPO G / TYPE G		222 223 224												
TYPE C / TIPO C / TYPE C		452 453 454												
		442 443 444												
		422 423 424												
		432 433 434												
		482 483 484												
		472 473 474												

 <p>Visiteur 4 pieds Confidente 4 patas 4 legs</p>	Accoudoirs fixes / Brazos fijos / Fixed arms	<table border="1"> <tr> <td>Structure Estructura Frame</td> <td>■</td> <td>■</td> <td>■</td> </tr> <tr> <td></td> <td>RAL 9005</td> <td>RAL 9006</td> <td></td> </tr> </table> <p>67.712-... 67.712-... 67.712-...</p>	Structure Estructura Frame	■	■	■		RAL 9005	RAL 9006	
Structure Estructura Frame	■	■	■							
	RAL 9005	RAL 9006								
<p><b>FINITIONS ACABADOS FINISHES</b></p>										
TYPE A / TIPO A / TYPE A		111 117 119								
TYPE G / TIPO G / TYPE G		321 327 329								
TYPE C / TIPO C / TYPE C		551 655 559								
		541 645 549								
		521 625 529								
		531 635 539								
		581 685 589								
		571 675 579								

# IMODÈLES | VARIANTES | VERSIONS

MODÈLE / VARIANTES / VERSIONS	TYPE / TIPO / TYPE	DIMENSIONS / MEDIDAS / MEASUREMENTS	RÉFÉRENCE / REFERENCIA / CODE								
 <p>Luge Balancin Cantilever</p>	Accoudoirs fixes / Brazos fijos / Fixed arms	<table border="1"> <tr> <td>Structure Estructura Frame</td> <td>■</td> <td>■</td> <td>■</td> </tr> <tr> <td></td> <td>RAL 9005</td> <td>RAL 9006</td> <td></td> </tr> </table> <p>67.812-... 67.812-... 67.812-...</p>	Structure Estructura Frame	■	■	■		RAL 9005	RAL 9006		<p><b>FINITIONS ACABADOS FINISHES</b></p>
Structure Estructura Frame	■	■	■								
	RAL 9005	RAL 9006									
TYPE A / TIPO A / TYPE A		111 117 119									
TYPE G / TIPO G / TYPE G		321 327 329									
TYPE C / TIPO C / TYPE C		551 655 559									
		541 645 549									
		521 625 529									
		531 635 539									
		581 685 589									
		571 675 579									

 <p>Visiteur 4 pieds avec tablette écritoire renforcée (noire) Confidente 4 patas con escribania reforzada (negro) 4 legs with writing tablet (black)</p>	À droite / Derecha / Right hand À gauche / Izquierda / Left hand	<table border="1"> <tr> <td>Structure Estructura Frame</td> <td>■</td> <td>■</td> <td>■</td> </tr> <tr> <td></td> <td>RAL 9005</td> <td>RAL 9006</td> <td></td> </tr> </table> <p>67.715-... 67.715-... 67.715-... 67.716-... 67.716-... 67.716-...</p>	Structure Estructura Frame	■	■	■		RAL 9005	RAL 9006		<p><b>FINITIONS ACABADOS FINISHES</b></p>
Structure Estructura Frame	■	■	■								
	RAL 9005	RAL 9006									
TYPE A / TIPO A / TYPE A		111 113 115									
TYPE G / TIPO G / TYPE G		321 323 325									
TYPE C / TIPO C / TYPE C		551 553 555									
		541 543 545									
		521 523 525									
		531 533 535									
		581 583 585									
		571 573 575									

## FINITIONS | ACABADOS | FINISHES

### STRUCTURE ET BASE ESTRUCTURA Y BASE FRAME AND BASE

■ Noire Negro Black	■ Noire + noire Negro + negro Black + black
■ Aluminium poli Aluminio pulido Polished aluminium	■ Aluminium + argentée Aluminio + plata Aluminium + silver
■ Argentée Plata Silver	■ Aluminium + chromée Aluminio + cromado Aluminium + chrome
■ Chromée Cromado Chrome	

### TYPE A TIPO A TYPE A ASSISE ET DOSSIER: TISSU AU CHOIX ASIENTO Y RESPALDO: TAPIZADO A ELEGIR UPHOLSTERED SEAT AND BACKREST

Cf. page 508  
Ver página 508  
See page 508

### TYPE G TIPO G TYPE G ASSISE: TISSU AU CHOIX ASIENTO: TAPIZADO A ELEGIR UPHOLSTERED SEAT

### DOSSIER EN RÉVILLE NOIRE RESPALDO EN REJILLA NEGRE BLACK MESH BACKREST

Cf. page 508  
Ver página 508  
See page 508

### TYPE C TIPO C TYPE C ASSISE ET DOSSIER EN POLYSTYRÈNE ASIENTO Y RESPALDO EN POLIESTIRENO SEAT AND BACKREST: POLYSTYRENE

■ Jaune Amarillo Yellow	■ Rouge Rojo Red	■ Bleu Azul Blue
■ Vert Verde Green	■ Anthracite Grafito Graphite	■ Blanc Blanco White

# BROS

Siège conçu pour aménager tous les espaces imaginables de bureaux, salles polyvalentes ou d'attente.

Diseñada y desarrollada para equipar todos los espacios imaginables en nuestras oficinas, zonas polivalentes y salas de espera.

Designed and created to furnish all type of spaces in the office, multipurpose zones and waiting areas.

SIÈGE  
DIRECTION

SILLA  
DIRECCIÓN

EXECUTIVE  
CHAIR



Réglable en hauteur  
Regulación altura  
Height adjustment

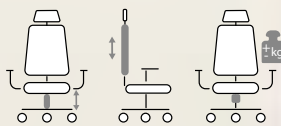

Accoudoirs réglables  
Regulación brazos  
Arms adjustment

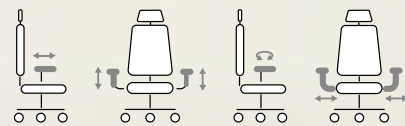

Assise réglable en profondeur  
Asiento regulable en profundidad  
Seat depth adjustment

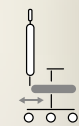

Mécanisme synchrone  
Mecanismo síncro  
Synchro mechanism



| SIÈGE OPÉRATIF

| OPERATIVA

| TASK CHAIR



Siège avec accoudoirs réglables ou sans accoudoirs.  
Se puede escoger sin brazos o con brazos regulables.  
With or without adjustable arms.

Réglable en hauteur  
Regulación altura  
Height adjustment

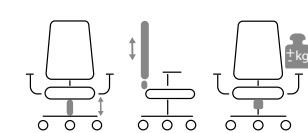

Support lombaire réglable  
Regulación lumbar  
Lumbar support adjustment

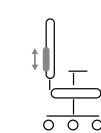

Accoudoirs réglables  
Regulación brazos  
Arms adjustment

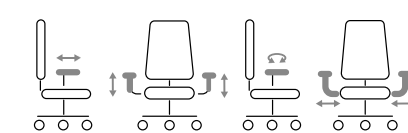

Assise réglable en profondeur  
Asiento regulable en profundidad  
Seat depth adjustment

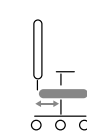

Mécanisme synchrone  
Mecanismo sincro  
Synchro mechanism

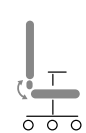



| VISITEUR  
| 4 PIEDS

| SILLA  
| 4 PATAS

| 4 LEGS  
| CHAIR



Structure en noir, argent, blanc,  
graphite ou chromé.  
La estructura de cuatro patas puede  
ser en acabado: negro, plata, blanco,  
grafito o cromado.  
Four legs structure is available in:  
black, silver, white, graphite or chrome  
finishes.



| VISITEUR  
| LUGE

| SILLA  
| BALANCÍN

| CANTILEVER  
| CHAIR



| Assise et dossier tapissé au choix.  
| Monocarcasa plástica tapizada.  
| Single upholstered shell.



Empilable  
Apilable  
Stackable



Disponible avec ou sans tablette écrite.  
Puede tener la pala escribanía  
como complemento.  
Writing tablet is available as a  
complement.

CHAISE PIEDS  
TRAÎNEAU

SILLA CON  
ESTRUCTURA PATÍN

SLED  
FRAME CHAIR













## MODÈLES | VARIANTES | VERSIONS

MODÈLE / VARIANTES / VERSIONS	TYPE / TIPO / TYPE	RÉFÉRENCE / REFERENCIA / CODE
 <p>Direction avec translation d'assise Dirección con traslo Executive with seat depth adjustment</p>	<p>Accoudoirs réglables / Brazos regulables / Adjustable arms</p>	<p>57.437. ... 57.437. ...</p> <p><b>FINITIONS ACABADOS FINISHES</b></p> <p>TYPE A / TIPO A / TYPE A 120 125 TYPE G / TIPO G / TYPE G 320 325</p>
 <p>Opératifs avec translation d'assise Operativa con traslo Task with seat depth adjustment</p>	<p>Sans accoudoirs / Sin brazos / Without arms</p> <p>Accoudoirs réglables / Brazos regulables / Adjustable arms</p>	<p>57.431. ... 57.431. ...</p> <p>57.433. ... 57.433. ...</p> <p><b>FINITIONS ACABADOS FINISHES</b></p> <p>TYPE A / TIPO A / TYPE A 120 125 TYPE G / TIPO G / TYPE G 320 325</p>



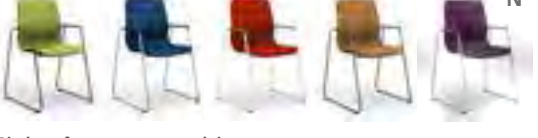

## FINITIONS | ACABADOS | FINISHES

<p>BASE BASE BASE</p> <p>Noire Negro Black</p> <p>Aluminium poli Aluminio pulido Polished aluminium</p>	<p>TYPE TIPO TYPE</p> <p><b>A</b></p> <p>ASSISE ET DOSSIER: TISSU AU CHOIX ASIENTO Y RESPALDO: TAPIZADO A ELEGIR UPHOLSTERED SEAT AND BACKREST</p> <p>Cf. page 508 Ver página 508 See page 508</p>	<p>COQUE DOSSIER EN PLYPROPYLÈNE NOIR CONTRARESPALDO POLIPROPILENO NEGRO BLACK POLYPROPYLENE BACKREST-COVER</p>
	<p>TYPE TIPO TYPE</p> <p><b>G</b></p> <p>ASSISE: TISSU AU CHOIX ASIENTO: TAPIZADO A ELEGIR UPHOLSTERED SEAT</p> <p>Cf. page 508 Ver página 508 See page 508</p>	<p>DOSSIER EN RÉVILLE NOIRE RESPALDO EN REJILLA NEGRA BLACK MESH BACKREST</p>

# MODÈLES | VARIANTES | VERSIONS

MODÈLE / VARIANTES / VERSIONS	TYPE / TIPO / TYPE	RÉFÉRENCE / REFERENCIA / CODE
 <p>Giratoire avec accoudoirs Giratoria con brazos Swivel</p>	<p>Structure avec roulettes / base con ruedas / base with castors</p> <p>Structure avec patins / base con topes / base with glides</p>	<p>57.002.101 57.102.101 57.402.101</p> <p>57.012.101 57.112.101 57.412.101</p>
 <p>4 Pieds avec accoudoirs 4 Patas con brazos 4 Legs with arms</p>		<p>57.072.101 57.172.101 57.272.101 57.372.101 57.472.101</p>
 <p>Luge avec accoudoirs Balancín con brazos Cantilever with arms</p>		<p>57.082.101 57.182.101 57.282.101 57.382.101 57.482.101</p>
 <p>Pieds traîneau avec accoudoirs Patin con brazos Sled frame with arms</p>		<p>57.094.101 57.194.101 57.294.101 57.394.101 57.494.101</p>
 <p>Pieds traîneau sans accoudoirs Patin sin brazos Sled frame without arms</p>		<p>57.093.101 57.193.101 57.293.101 57.393.101 57.493.101</p>
 <p>Pieds traîneau avec accoudoirs Patin con brazos Sled frame with arms</p>		<p>57.092.--- 57.192.--- 57.292.--- 57.392.--- 57.492.---</p>
 <p>Pieds traîneau sans accoudoirs Patin sin brazos Sled frame without arms</p>		<p>57.091.--- 57.191.--- 57.291.--- 57.391.--- 57.491.---</p>





# MODÈLES | VARIANTES | VERSIONS

MODÈLE / VARIANTES / VERSIONS	RÉFÉRENCE / REFERENCIA / CODE
 <p>Pieds traîneau avec accoudoirs, tablette écriteure à droite (noire) Patin con brazos, escribanía mano derecha (negra) Sled frame with arms, RIGHT hand writing tablet (black)</p>	<p>57.097.101 57.197.101 57.297.101 57.397.101 57.497.101</p>
 <p>Pieds traîneau avec accoudoirs, tablette écriteure à gauche (noire) Patin con brazos, escribanía mano izquierda (negra) Sled frame with arms, LEFT hand writing tablet (black)</p>	<p>57.098.101 57.198.101 57.298.101 57.398.101 57.498.101</p>
 <p>Pieds traîneau avec accoudoirs, tablette écriteure à droite (noire) Patin con brazos, escribanía mano derecha (negra) Sled frame with arms, RIGHT hand writing tablet (black)</p>	<p>57.095.--- 57.195.--- 57.295.--- 57.395.--- 57.495.---</p>
 <p>Pieds traîneau avec accoudoirs, tablette écriteure à gauche (noire) Patin con brazos, escribanía mano izquierda (negra) Sled frame with arms, LEFT hand writing tablet (black)</p>	<p>57.096.--- 57.196.--- 57.296.--- 57.396.--- 57.496.---</p>

# FINITIONS | ACABADOS | FINISHES

\* PCF = 75% PP + 20% calcium + 5% FG

## STRUCTURE ESTRUCTURA FRAME

	Noire Negro Black
	Argentée Plata Silver
	Blanche Blanco White
	Graphite Grafito Graphite
	Chromée Cromado Chrome







## TYPE TIPO TYPE

**N** ASSISE ET DOSSIER: TISSU AU CHOIX  
ASIENTO Y RESPALDO: TAPIZADO A ELEGIR  
UPHOLSTERED SEAT AND BACKREST

 Cf. page 508  
Ver página 508  
See page 508







## TYPE TIPO TYPE

**O** ASSISE ET DOSSIER EN \*PC + ABS  
ASIENTO Y RESPALDO EN \*PC + ABS  
\*PC + ABS SEAT AND BACKREST

	211	Noir Negro Black		271	Blanc Blanco White		221	Bleu Azul Blue		241	Rouge Rojo Red
	231	Vert pistache Verde pistacho Pistachio green		281	Graphite Grafito Graphite		461	Imitation Chêne Imitación Roble Maple imitation			

## TYPE TIPO TYPE

**P** DOSSIER EN \*PC + ABS  
RESPALDO EN \*PC + ABS  
\*PC + ABS BACKREST

	811	Noir Negro Black		871	Blanc Blanco White		821	Bleu Azul Blue		841	Rouge Rojo Red
	831	Vert pistache Verde pistacho Pistachio green		881	Graphite Grafito Graphite		471	Imitation Chêne Imitación Roble Maple imitation			

ASSISE: TISSU AU CHOIX  
ASIENTO: TAPIZADO A ELEGIR  
UPHOLSTERED SEAT

 Cf. page 508  
Ver página 508  
See page 508

SIÈGE OPÉRATIF 24H  
OPERATIVA 24H  
24H TASK CHAIR

046 | SOLID



# SOLID

Ce siège opératif 24h/24 se caractérise par son ergonomie, son confort et sa résistance sans renoncer à l'esthétique. Ses excellentes finitions et son dossier enveloppant procurent un bien-être tout au long de la journée

Esta silla operativa 24h se caracteriza por su ergonomía, confort y resistencia sin renunciar a la estética. Destacan sus acabados excelentes y su respaldo envolvente que proporciona bienestar durante toda la jornada.

This 24-hour operating chair is characterized by its ergonomics, comfort and resistance and at the same time good-looking. Its excellent finishes and its fully upholstered back provides well-being throughout the shift.





SIÈGE  
OPÉRATIF

SILLA  
OPERATIVA

TASK  
CHAIR



Tête réglable  
Regulación cabezal  
Headrest adjustment

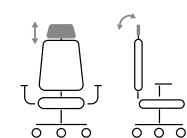

Réglable en hauteur  
Regulación altura  
Height adjustment

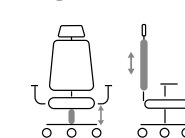

Accoudoirs réglables  
Regulación brazos  
Arms adjustment

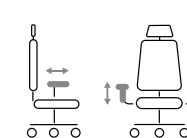

Assise réglable en profondeur  
Asiento regulable en profundidad  
Seat depth adjustment



Mécanisme synchrone  
Mecanismo sincro  
Synchro mechanism

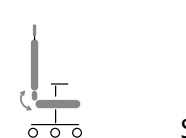

## MODÈLES | VARIANTES | VERSIONS

MODÈLE / VARIANTES / VERSIONS	TYPE / TIPO / TYPE	RÉFÉRENCE / REFERENCIA / CODE
	Translation d'assise / Traslo / Seat depth adjustment Accoudoirs réglables / Brazos regulables / Adjustable arms	173.929.107

## FINITIONS | ACABADOS | FINISHES

BASE  
BASE  
BASE

Aluminium poli  
Aluminio pulido  
Polished aluminium

ASSISE ET DOSSIER: TISSU AU CHOIX  
ASIENTO Y RESPALDO: TAPIZADO A ELEGIR  
UPHOLSTERED SEAT AND BACKREST

Cf. page 508  
Ver pagina 508  
See page 508

\*Non tapissable en PUMA et EVOLVE  
\*No se puede tapizar con PUMA y EVOLVE  
\*PUMA and EVOLVE fabrics are not available



SIÈGES OPÉRATIFS  
OPERATIVAS  
TASK CHAIRS



054 | ITA



062 | KLASS



072 | WHY



078 | ARO



086 | M4



094 | VIGO



102 | PLUS



108 | PORTO



114 | EXAGONUS



120 | COPA



126 | LOGOS



132 | IRIS



138 | LOTUS

# ita

Sièges et fauteuils opératifs disponibles dans de nombreuses versions. Une gamme de sièges design et confortable dont les éléments structurels sont de grande qualité et résistance.

Silla y sillón operativos con múltiples posibilidades. Una gama de sillería que destaca por su diseño y confort, junto con unos elementos estructurales de gran calidad y resistencia.

Executive and task chair with multiple possibilities. A range of seats that stands out for its design and comfort, along with some structural elements of high quality and durability.

| SIÈGE OPÉRATIF

| OPERATIVA

| TASK CHAIR

Réglable en hauteur  
Regulación altura  
Height adjustment

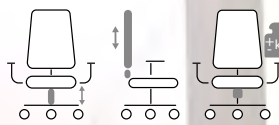

Support lombaire réglable  
Regulación lumbar  
Lumbar support adjustment

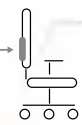

Accoudoirs réglables  
Regulación brazos  
Arms adjustment

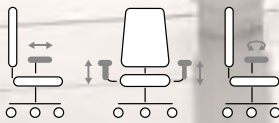

Assise réglable en profondeur  
Asiento regulable en profundidad  
Seat depth adjustment



Mécanisme synchrone  
Mecanismo sincro  
Synchro mechanism







OPÉRATIF  
AVEC TÊTIÈRE

OPERATIVA  
CON CABEZAL

TASK CHAIR  
WITH HEADREST



Siège avec accoudoirs réglables, fixes ou sans accoudoirs.  
Disponibile con braccioli regolabili, fissi o sin braccioli.  
With or without adjustable or fixed arms.

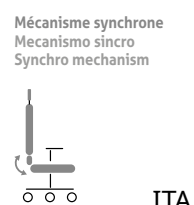
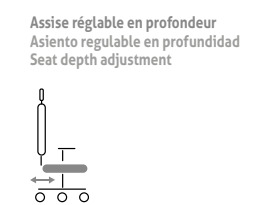
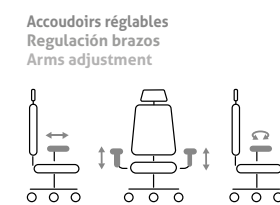
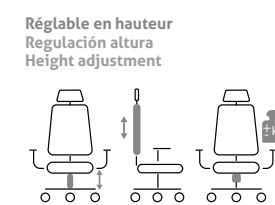
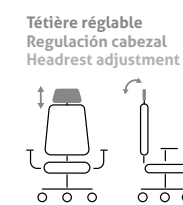

| VISITEUR  
| LUGE

| CONFIDENTE  
| BALANCÍN

| CANTILEVER  
| CHAIR

Structure disponible en blanc, noir,  
argent ou chromé.  
Disponibile con struttura in bianco,  
negro, plata o cromado.  
Available frame in: black, white, silver  
or chrome finishes.



## MODÈLES | VARIANTES | VERSIONS

MODÈLE / VARIANTES / VERSIONS	TYPE / TIPO / TYPE	RÉFÉRENCE / REFERENCIA / CODE	
	Accoudoirs fixes / Con brazos / Fixed arms	151.098.327	151.598.327
	Accoudoirs réglables / Brazos regulables / Adjustable arms	151.099.327	151.599.327
	Accoudoirs fixes / Con brazos / Fixed arms	151.038.327	151.538.327
	Accoudoirs réglables / Brazos regulables / Adjustable arms	151.039.327	151.539.327





Opératif avec tête et translation d'assise  
Operativa con cabezal y traslo  
Task chair with headrest and seat depth adjustment

	Accoudoirs fixes / Con brazos / Fixed arms	151.098.377	151.598.377
	Accoudoirs réglables / Brazos regulables / Adjustable arms	151.099.377	151.599.377
	Accoudoirs fixes / Con brazos / Fixed arms	151.038.377	151.538.377
	Accoudoirs réglables / Brazos regulables / Adjustable arms	151.039.377	151.539.377

Siège Opératif avec tête. Support lombaire réglable et translation d'assise  
Operativa con cabezal, lumbar ajustable y traslo  
Task chair with headrest, lumbar support and seat depth adjustment

	Sans accoudoirs / Sin brazos / Without arms	151.091.327	151.591.327
	Accoudoirs fixes / Con brazos / Fixed arms	151.092.327	151.592.327
	Accoudoirs réglables / Brazos regulables / Adjustable arms	151.093.327	151.593.327
	Sans accoudoirs / Sin brazos / Without arms	151.031.327	151.531.327
	Accoudoirs fixes / Con brazos / Fixed arms	151.032.327	151.532.327
	Accoudoirs réglables / Brazos regulables / Adjustable arms	151.033.327	151.533.327

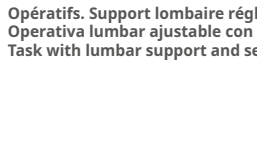
Opératifs avec translation d'assise  
Operativa con traslo  
Task with seat depth adjustment

	Sans accoudoirs / Sin brazos / Without arms	151.091.377	151.591.377
	Accoudoirs fixes / Con brazos / Fixed arms	151.092.377	151.592.377
	Accoudoirs réglables / Brazos regulables / Adjustable arms	151.093.377	151.593.377
	Sans accoudoirs / Sin brazos / Without arms	151.031.377	151.531.377
	Accoudoirs fixes / Con brazos / Fixed arms	151.032.377	151.532.377
	Accoudoirs réglables / Brazos regulables / Adjustable arms	151.033.377	151.533.377

Opératifs. Support lombaire réglable et translation d'assise.  
Operativa lumbar ajustable con traslo  
Task with lumbar support and seat depth adjustment

## FINITIONS | ACABADOS | FINISHES

BASE + COQUE  
BASE + CARCASA  
BASE + SHELL

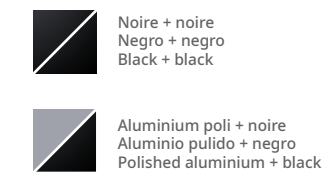





DOSSIER EN RÉVILLE  
RESPALDO EN REJILLA  
MESH BACKREST

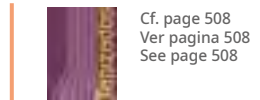

ASSISE ET TÊTIÈRE: TISSU AU CHOIX  
ASIENTO Y CABEZAL: TAPIZADO A ELEGIR  
UPHOLSTERED SEAT AND HEADREST



## MODÈLES | VARIANTES | VERSIONS

MODÈLE / VARIANTES / VERSIONS	RÉFÉRENCE / REFERENCIA / CODE			
				
	151.082.327	151.182.327	151.782.327	151.482.327

Luge  
Balancín  
Cantilever

## FINITIONS | ACABADOS | FINISHES

STRUCTURE + COQUE  
ESTRUCTURA + CARCASA  
FRAME + SHELL



ASSISE: TISSU AU CHOIX  
ASIENTO: TAPIZADO A ELEGIR  
UPHOLSTERED SEAT

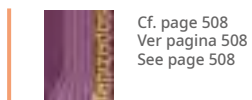

# klass

| SIÈGE OPÉRATIF

| OPERATIVA

| TASK CHAIR

Polyvalence et esthétique qualifient cette famille de sièges au design contemporain. L'ergonomie du siège KLASS est renforcé par les formes actuelles et prononcées de ses différents modèles d'accoudoirs.

Versatilidad y estética. Modelo con un diseño ergonómico de líneas rectas y puras en el que destaca su versatilidad y variedad de posibilidades. KLASS presume de un carácter acentuado gracias a sus diferentes reposabrazos de formas muy pronunciadas.

Versatility and design. Ergonomic chair with straight and defined lines that maximize its versatility and the variety of models. The distinct armrests give this chair an outstanding character.

Réglable en hauteur  
Regulación altura  
Height adjustment

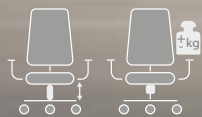

Soutien lombaire réglable  
Regulación lumbar  
Lumbar support adjustment

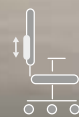

Accoudoirs réglables  
Regulación brazos  
Arms adjustment

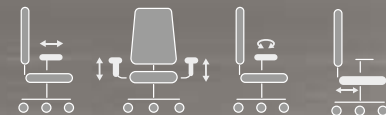

Assise réglable en profondeur  
Asiento regulable en profundidad  
Seat depth adjustment



Mécanisme synchrone  
Mecanismo sincro  
Synchro mechanism



OPÉRATIF  
AVEC TÊTIÈRE

OPERATIVA  
CON CABEZAL

TASK CHAIR  
WITH HEADREST



Tête aussi en tissu.  
El cabezal es un elemento que se  
tapiza también.  
Headrest can be upholstered aswell.



Tête réglable  
Regulación cabezal  
Headrest adjustment

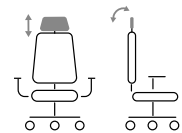

Réglable en hauteur  
Regulación altura  
Height adjustment

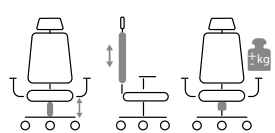

Accoudoirs réglables  
Regulación brazos  
Arms adjustment

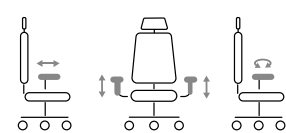

Assise réglable en profondeur  
Asiento regulable en profundidad  
Seat depth adjustment

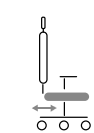

Mécanisme synchrone  
Mecanismo sincro  
Synchro mechanism

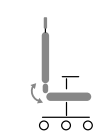

| SIÈGE OPÉRATIF

| OPERATIVA

| TASK CHAIR

Siège opératif et luge peuvent avoir le dossier en résille ou tapissé.  
La silla operativa y balancín pueden tener el respaldo tapizado o con rejilla.  
Task chair and cantilever can have meshed or upholstered backrest.



Accoudoirs fixes.  
Brazos fijos.  
Fixed arms.

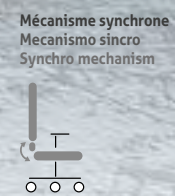
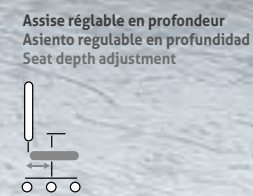
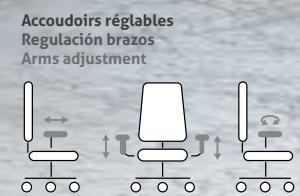

| VISITEUR  
| LUGE

| CONFIDENTE  
| BALANCÍN











| CANTILEVER  
| CHAIR



Deux modèles d'accoudoirs fixes.  
Las brazos fijos tienen 2 diseños muy característicos.  
Fixed arms are available in 2 different shapes.



## MODÈLES | VARIANTES | VERSIONS

MODÈLE / VARIANTES / VERSIONS	TYPE / TIPO / TYPE	RÉFÉRENCE / REFERENCIA / CODE			
	Accoudoirs fixes / Con brazos / Fixed arms				
		144.098.107	144.298.108	144.598.107	144.598.108
	Accoudoirs réglables / Brazos regulables / Adjustable arms				
		144.099.107		144.599.107	
<b>Opératif avec tête et translation d'assise</b> <b>Operativa con cabezal y traslo</b> <b>Task chair with headrest and seat depth adjustment</b>					
	Accoudoirs fixes / Con brazos / Fixed arms				
		144.038.107	144.238.108	144.538.107	144.538.108
	Accoudoirs réglables / Brazos regulables / Adjustable arms				
		144.039.107		144.539.107	
<b>Opératif avec tête</b> <b>Operativa con cabezal</b> <b>Task chair with headrest</b>					
	Sans accoudoirs / Sin brazos / Without arms				
		144.091.107	144.291.108	144.591.107	144.591.108
	Accoudoirs fixes / Con brazos / Fixed arms				
		144.092.107	144.292.108	144.592.107	144.592.108
	Accoudoirs réglables / Brazos regulables / Adjustable arms				
		144.093.107		144.593.107	
<b>Opératifs avec translation d'assise</b> <b>Operativa con traslo</b> <b>Task with seat depth adjustment</b>					
	Sans accoudoirs / Sin brazos / Without arms				
		144.031.107	144.231.108	144.531.107	144.531.108
	Accoudoirs fixes / Con brazos / Fixed arms				
		144.032.107	144.232.108	144.532.107	144.532.108
	Accoudoirs réglables / Brazos regulables / Adjustable arms				
		144.033.107		144.533.107	
<b>Opératifs</b> <b>Operativa</b> <b>Task</b>					
	Sans accoudoirs / Sin brazos / Without arms				
		144.091.327	144.791.326	144.591.327	144.591.326
	Accoudoirs fixes 1 / Con brazos 1 / Fixed arms 1				
		144.092.327	144.792.326	144.592.327	144.592.326
	Accoudoirs fixes 2 / Con brazos 2 / Fixed arms 2				
		144.090.327	144.790.326	144.590.327	144.590.326
	Accoudoirs réglables / Brazos regulables / Adjustable arms				
		144.093.327	144.793.326	144.593.327	144.593.326
<b>Opératifs avec translation d'assise et dossier résille</b> <b>Operativa con traslo y respaldo rejilla</b> <b>Task with seat depth adjustment and meshed backrest</b>					
	Sans accoudoirs / Sin brazos / Without arms				
		144.031.327	144.731.326	144.531.327	144.531.326
	Accoudoirs fixes 1 / Con brazos 1 / Fixed arms 1				
		144.032.327	144.732.326	144.532.327	144.532.326
	Accoudoirs fixes 2 / Con brazos 2 / Fixed arms 2				
		144.030.327	144.730.326	144.530.327	144.530.326
	Accoudoirs réglables / Brazos regulables / Adjustable arms				
		144.033.327	144.733.326	144.533.327	144.533.326
<b>Opératifs avec dossier résille</b> <b>Operativa con respaldo en rejilla</b> <b>Task with meshed backrest</b>					

## FINITIONS | ACABADOS | FINISHES

BASE + COQUE  
BASE + CARCASA  
BASE + SHELL

 Noire + noire  
Negro + negro  
Black + black

 Aluminium poli + noire  
Aluminio pulido + negro  
Polished aluminium + black

 Grise + grise  
Gris + gris  
Grey + grey

 Aluminium poli + grise  
Aluminio pulido + gris  
Polished aluminium + grey

ASSISE ET DOSSIER: TISSU AU CHOIX  
ASIENTO Y RESPALDO: TAPIZADO A ELEGIR  
UPHOLSTERED SEAT AND BACKREST



Cf. page 508  
Ver pagina 508  
See page 508

## MODÈLES | VARIANTES | VERSIONS

MODÈLE / VARIANTES / VERSIONS	TYPE / TIPO / TYPE	RÉFÉRENCE / REFERENCIA / CODE			
	Sans accoudoirs / Sin brazos / Without arms				
		144.081.107	144.181.108	144.481.107	144.481.108
	Accoudoirs fixes / Con brazos / Fixed arms				
		144.082.107	144.182.108	144.482.107	144.482.108
<b>Luge</b> <b>Balancín</b> <b>Cantilever</b>					
	Sans accoudoirs / Sin brazos / Without arms				
		144.081.327	144.781.326	144.481.327	144.481.326
	Accoudoirs fixes 1 / Con brazos 1 / Fixed arms 1				
		144.082.327	144.782.326	144.482.327	144.482.326
	Accoudoirs fixes 2 / Con brazos 2 / Fixed arms 2				
		144.080.327	144.780.326	144.480.327	144.480.326
<b>Luge</b> <b>Balancín</b> <b>Cantilever</b>					

## FINITIONS | ACABADOS | FINISHES

STRUCTURE + COQUE  
ESTRUCTURA + CARCASA  
FRAME + SHELL

ASSISE: TISSU AU CHOIX  
ASIENTO: TAPIZADO A ELEGIR  
UPHOLSTERED SEAT

 Noire + noire  
Negro + negro  
Black + black  
RAL 9005

 Argentée + grise  
Plata + gris  
Silver + grey  
RAL 9006

 Blanche + blanche  
Blanco + blanco  
White + white  
RAL 9016

 Chromée + noire  
Cromado + negro  
Chrome + black

 Chromée + grise  
Cromado + gris  
Chrome + grey

 Chromée + blanche  
Cromado + blanco  
Chrome + white



Cf. page 508  
Ver pagina 508  
See page 508



# Why

| SIÈGE OPÉRATIF

| OPERATIVA

| TASK CHAIR

WHY est un siège opératif aux formes modernes et ergonomiques satisfaisant tous les besoins de l'utilisateur. Respectueux de l'environnement, 98% des composants du siège WHY sont recyclables.

WHY es una silla operativa con formas modernas y ergonómicas que cubre las necesidades básicas del trabajador. Respetuosa con el medio ambiente con un 98% de sus componentes reciclables.

Task chair that provides contemporary design and ergonomic features satisfying employees basic requirements. Environment-friendly chair with 98% recyclable components.



Réglable en hauteur  
Regulación altura  
Height adjustment

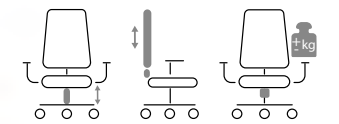

Accoudoirs réglables  
Regulación brazos  
Arms adjustment

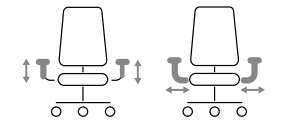

Assise réglable en profondeur  
Asiento regulable en profundidad  
Seat depth adjustment

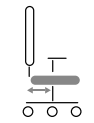

Mécanisme synchrone  
Mecanismo sincro  
Synchro mechanism

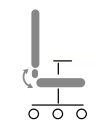

SIÈGE OPÉRATIF  
REMOURRÉ

SILLA OPERATIVA  
TAPIZADA

UPHOLSTERED  
TASK CHAIR



Possibilité d'avoir le dossier rembourré.  
El respaldo puede ser tapizado.  
Backrest can be upholstered aswell.

Siège disponible avec ou sans accoudoirs.  
Disponibile con o sin brazos.  
With or without adjustable arms.



Coque dossier disponible en noir, gris ou blanc.  
Respaldo disponible en color, negro, gris o blanco.  
Available backrest finishes: black, grey or white.

## MODÈLES | VARIANTES | VERSIONS

MODÈLE / VARIANTES / VERSIONS	TYPE / TIPO / TYPE	RÉFÉRENCE / REFERENCIA / CODE
	Sans accoudoirs / Sin brazos / Without arms	145.901.2 - -
	Accoudoirs réglables / Brazos regulables / Adjustable arms	145.903.2 - -

Opératifs avec translation d'assise. Dossier réjille  
Operativa con traslo y respaldo rejilla  
Task with seat depth adjustment and meshed backrest

## FINITIONS | ACABADOS | FINISHES

BASE  
BASE  
BASE

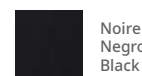

Noire  
Negro  
Black



Aluminium poli  
Aluminio pulido  
Polished aluminium

DOSSIER RÉJILLE  
RESPALDO REJILLA  
BACKREST MESH



10

Noir  
Negro  
Black



60

Gris  
Gris  
Grey

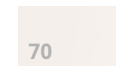

70

Blanc  
Blanco  
White



14

Noir  
Negro  
Black



64

Gris  
Gris  
Grey



74

Blanc  
Blanco  
White

ASSISE: TISSU AU CHOIX  
ASIENTO: TAPIZADO A ELEGIR  
UPHOLSTERED SEAT



Cf. page 508  
Ver pagina 508  
See page 508

## MODÈLES | VARIANTES | VERSIONS

	Sans accoudoirs / Sin brazos / Without arms	145.901.8 - -
	Accoudoirs réglables / Brazos regulables / Adjustable arms	145.903.8 - -

Opératifs avec translation d'assise. Dossier rembourré  
Operativa con traslo. Respaldo tapizado  
Upholstered backrest. Task with seat depth adjustment

## FINITIONS | ACABADOS | FINISHES

BASE  
BASE  
BASE



Noire  
Negro  
Black



Aluminium poli  
Aluminio pulido  
Polished aluminium

COQUE  
CARCASA  
SHELL



10

Noir  
Negro  
Black



60

Gris  
Gris  
Grey



70

Blanche  
Blanco  
White



14

Noir  
Negro  
Black



64

Gris  
Gris  
Grey



74

Blanche  
Blanco  
White

ASSISE ET DOSSIER: TISSU AU CHOIX  
ASIENTO Y RESPALDO: TAPIZADO A ELEGIR  
UPHOLSTERED SEAT AND BACKREST



Cf. page 508  
Ver pagina 508  
See page 508



# Aro

Siège tapissé aux multiples possibilités. Le siège ARO est agrémenté d'un enjoliveur chromé en partie basse du dossier qui lui confère une touche originale et élégante.

Esta silla tiene un respaldo con un embellecedor cromado en la parte inferior que le da un toque original muy especial.

ARO backrest has an original chrome detail that makes this chair very special.

SIÈGE OPÉRATIF  
REMOURRÉ

SILLA OPERATIVA  
TAPIZADA

UPHOLSTERED  
TASK CHAIR



Réglable en hauteur  
Regulación altura  
Height adjustment

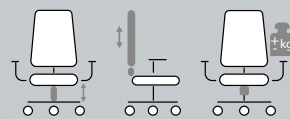

Accoudoirs réglables  
Regulación brazos  
Arms adjustment

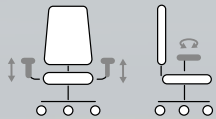

Assise réglable en profondeur  
Asiento regulable en profundidad  
Seat depth adjustment

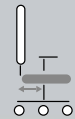

Mécanisme synchrone  
Mecanismo sincro  
Synchro mechanism





OPÉRATIF  
AVEC TÊTIÈRE

OPERATIVA  
CON CABEZAL

TASK CHAIR  
WITH HEADREST



Base chromée ou noire.  
La base puede ser cromada o negra.  
Black or chrome base.

Tête réglable  
Regulación cabezal  
Headrest adjustment

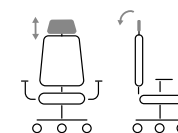

Réglable en hauteur  
Regulación altura  
Height adjustment

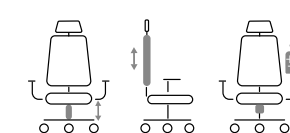

Accoudoirs réglables  
Regulación brazos  
Arms adjustment

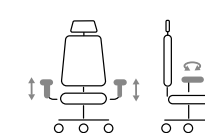

Assise réglable en profondeur  
Asiento regulable en profundidad  
Seat depth adjustment



Mécanisme synchrone  
Mecanismo síncro  
Synchro mechanism



| VISITEUR  
| LUGE









| CONFIDENTE  
| BALANCÍN

| CANTILEVER  
| CHAIR



Dossier avec un détail chromé.  
Detalle cromado del respaldo.  
Chrome detail of the backrest.

## MODÈLES | VARIANTES | VERSIONS

MODÈLE / VARIANTES / VERSIONS	TYPE / TIPO / TYPE	RÉFÉRENCE / REFERENCIA / CODE	
 <p>Opératif avec tête et translation d'assise Operativa con cabezal y traslo Task chair with headrest and seat depth adjustment</p>	Accoudoirs réglables / Brazos regulables / Adjustable arms	 137.329.111  137.329.118	
 <p>Opératif avec tête Operativa con cabezal Task chair with headrest</p>	Accoudoirs réglables / Brazos regulables / Adjustable arms	137.029.111	137.029.118
 <p>Opératifs avec translation d'assise Operativa con traslo Task with seat depth adjustment</p>	Sans accoudoirs / Sin brazos / Without arms Accoudoirs fixes / Con brazos fijos / Fixed arms Accoudoirs réglables / Brazos regulables / Adjustable arms	137.301.111 137.302.111 137.303.111	137.301.118 137.302.118 137.303.118
 <p>Opératifs Operativa Task</p>	Sans accoudoirs / Sin brazos / Without arms Accoudoirs fixes / Con brazos fijos / Fixed arms Accoudoirs réglables / Brazos regulables / Adjustable arms	137.001.111 137.002.111 137.003.111	137.001.118 137.002.118 137.003.118

## FINITIONS | ACABADOS | FINISHES





BASE  
BASE  
BASE

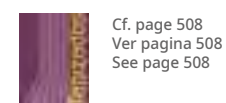

ASSISE, DOSSIER ET TÊTIÈRE: TISSU AU CHOIX  
ASIENTO, RESPALDO Y CABEZAL: TAPIZADO A ELEGIR  
UPHOLSTERED SEAT, BACKREST AND HEADREST



## MODÈLES | VARIANTES | VERSIONS

MODÈLE / VARIANTES / VERSIONS	TYPE / TIPO / TYPE	RÉFÉRENCE / REFERENCIA / CODE	
 <p>Luge Balancin Cantilever</p>	Sans accoudoirs / Sin brazos / Without arms Accoudoirs fixes / Con brazos fijos / Fixed arms	 137.801.111  137.801.118	 137.802.111  137.802.118

## FINITIONS | ACABADOS | FINISHES

STRUCTURE  
ESTRUCTURA  
FRAME

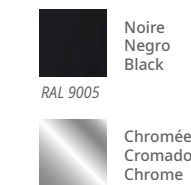

ASSISE ET DOSSIER: TISSU AU CHOIX  
ASIENTO Y RESPALDO: TAPIZADO A ELEGIR  
UPHOLSTERED SEAT AND BACKREST

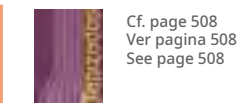

# M4

Siège opératif, disponible en plusieurs dimensions de dossier. Mécanisme synchrone.

Sillón operativo, en diferentes medidas de respaldo con mecanismo sincro, con un alto grado de funcionalidad y confort.

Task chair, available in different backrest sizes, synchro mechanism, high comfort and functionality.

| SIÈGE OPERATIF

| SILLA OPERATIVA

| TASK CHAIR

Réglable en hauteur  
Regulación altura  
Height adjustment

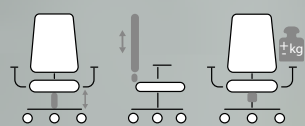

Accoudoirs réglables  
Regulación brazos  
Arms adjustment

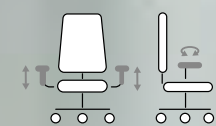

Assise réglable en profondeur  
Asiento regulable en profundidad  
Seat depth adjustment



Mécanisme synchrone  
Mecanismo sincro  
Synchro mechanism







OPÉRATIF -  
DOSSIER HAUT

OPERATIVA -  
RESPALDO ALTO

TASK CHAIR -  
HIGH BACKREST

Dossier haut disponible.  
Respaldo alto disponible.  
High backrest available.



Réglable en hauteur  
Regulación altura  
Height adjustment

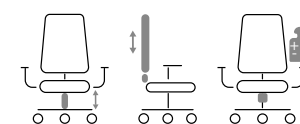

Accoudoirs réglables  
Regulación brazos  
Arms adjustment

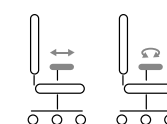

Assise réglable en profondeur  
Asiento regulable en profundidad  
Seat depth adjustment



Mécanisme synchrone  
Mecanismo sincro  
Synchro mechanism



|VISITEUR  
|LUGE

|CONFIDENTE  
|BALANCÍN

|CANTILEVER  
|CHAIR



Siège piètement luge.  
Silla de visita con estructura patín.  
Visitor chair with cantilever frame.



## MODÈLES | VARIANTES | VERSIONS

MODÈLE / VARIANTES / VERSIONS	TYPE / TIPO / TYPE	RÉFÉRENCE / REFERENCIA / CODE
	Sans accoudoirs / Sin brazos / Without arms	104.321.001
Opératifs avec translation d'assise - Dossier haut Operativa con traslo - Respaldo alto Task with seat depth adjustment - High backrest	Accoudoirs réglables / Brazos regulables / Adjustable arms	104.323.001
	Sans accoudoirs / Sin brazos / Without arms	104.301.001
Opératifs avec translation d'assise - Dossier moyen Operativa con traslo - Respaldo medio Task with seat depth adjustment - Medium backrest	Accoudoirs réglables / Brazos regulables / Adjustable arms	104.303.001
	Sans accoudoirs / Sin brazos / Without arms	104.311.001
Opératifs avec translation d'assise - Dossier bas Operativa con traslo - Respaldo bajo Task with seat depth adjustment - Low backrest	Accoudoirs réglables / Brazos regulables / Adjustable arms	104.313.001

## FINITIONS | ACABADOS | FINISHES

BASE  
BASE  
BASE



Noire  
Negro  
Black



Aluminium poli  
Aluminio pulido  
Polished aluminium

ASSISE ET DOSSIER: TISSU AU CHOIX  
ASIENTO Y RESPALDO: TAPIZADO A ELEGIR  
UPHOLSTERED SEAT AND BACKREST



Cf. page 508  
Ver pagina 508  
See page 508

## MODÈLES | VARIANTES | VERSIONS

	Accoudoirs fixes / Con brazos / Fixed arms	104.812.001
Luge Balancín Cantilever		

## FINITIONS | ACABADOS | FINISHES

STRUCTURE  
ESTRUCTURA  
FRAME



Chromée  
Cromado  
Chrome



Cf. page 508  
Ver pagina 508  
See page 508



# Vigo

Siège ergonomique avec mécanisme synchro de grande performance et plus de confort.

Silla ergonómica con mecanismo sincronizado de 3 posiciones y grandes prestaciones, posibilitando un mayor confort en el trabajo.

Ergonomic chair with synchro mechanism and high performance, providing a great comfort at workplaces.

## | SIÈGE OPERATIF

Réglable en hauteur  
Regulación altura  
Height adjustment

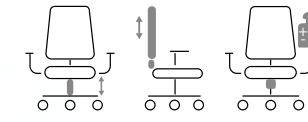

Support lombaire réglable  
Regulación lumbar  
Lumbar support adjustment

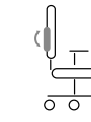

## | SILLA OPERATIVA

Accoudoirs réglables  
Regulación brazos  
Arms adjustment

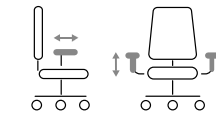

Assise réglable en profondeur  
Asiento regulable en profundidad  
Seat depth adjustment

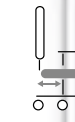

## | TASK CHAIR

Mécanisme synchrone  
Mecanismo sincro  
Synchro mechanism





OPÉRATIF  
AVEC TÊTIÈRE

OPERATIVA  
CON CABEZAL

TASK CHAIR  
WITH HEADREST

Dossier résille disponible en noir, bleu ou rouge.  
Rejilla disponible en negro, azul o rojo.  
Backrest mesh available in black, blue or red finishes.



Tête réglable  
Regulación cabezal  
Headrest adjustment

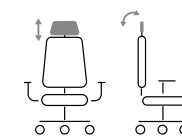

Réglable en hauteur  
Regulación altura  
Height adjustment

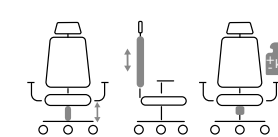

Support lombaire réglable  
Regulación lumbar  
Lumbar support adjustment

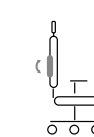

Accoudoirs réglables  
Regulación brazos  
Arms adjustment

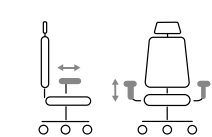

Assise réglable en profondeur  
Asiento regulable en profundidad  
Seat depth adjustment

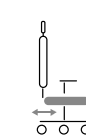

Mécanisme synchrone  
Mecanismo síncro  
Synchro mechanism

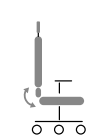

VISITEUR  
LUGE

CONFIDENTE  
BALANCÍN

CANTILEVER  
CHAIR











Accoudoirs fixes.  
Brazos fijos.  
Fixed arms.

Siège visiteur avec support lombaire.  
La silla de visita dispone de soporte lumbar.  
Visitor chair has lumbar support.



## MODÈLES | VARIANTES | VERSIONS

MODÈLE / VARIANTES / VERSIONS	TYPE / TIPO / TYPE	RÉFÉRENCE / REFERENCIA / CODE
	Accoudoirs réglables / Brazos regulables / Adjustable arms	135.329-...
Opératif avec tête et translation d'assise Operativa con cabezal y traslo Task chair with headrest and seat depth adjustment		
	Accoudoirs réglables / Brazos regulables / Adjustable arms	135.029-...
Opératif avec tête Operativa con cabezal Task chair with headrest		
	Sans accoudoirs / Sin brazos / Without arms	135.301-...
	Accoudoirs fixes / Brazos fijos / Fixed arms	135.302-...
Opératifs avec translation d'assise Operativa con traslo Task with seat depth adjustment		
	Accoudoirs réglables / Brazos regulables / Adjustable arms	135.303-...
	Sans accoudoirs / Sin brazos / Without arms	135.001-...
	Accoudoirs fixes / Brazos fijos / Fixed arms	135.002-...
Opératifs Operativa Task		
	Accoudoirs réglables / Brazos regulables / Adjustable arms	135.003-...

## FINITIONS | ACABADOS | FINISHES

BASE  
BASE  
BASE

Noire  
Negro  
Black

Aluminium poli  
Aluminio pulido  
Polished aluminium

DOSSIER EN RÉVILLE  
RESPALDO REJILLA  
MESH BACKREST

321 Noir Negro Black 381 Rouge Rojo Red 391 Bleu Azul Blue

328 Noir Negro Black 388 Rouge Rojo Red 398 Bleu Azul Blue

ASSISE: TISSU AU CHOIX  
ASIENTO: TAPIZADO A ELEGIR  
UPHOLSTERED SEAT

Cf. page 508  
Ver pagina 508  
See page 508

## MODÈLES | VARIANTES | VERSIONS

MODÈLE / VARIANTES / VERSIONS	TYPE / TIPO / TYPE	RÉFÉRENCE / REFERENCIA / CODE
	Sans accoudoirs / Sin brazos / Without arms	135.801-...
	Accoudoirs fixes / Con brazos / Fixed arms	135.802-...
Luge Balancín Cantilever		

## FINITIONS | ACABADOS | FINISHES

STRUCTURE  
ESTRUCTURA  
FRAME

Noire  
Negro  
Black  
RAL 9005

Chromée  
Cromado  
Chrome

DOSSIER EN RÉVILLE  
RESPALDO REJILLA  
MESH BACKREST

321 Noir Negro Black 381 Rouge Rojo Red 391 Bleu Azul Blue

328 Noir Negro Black 388 Rouge Rojo Red 398 Bleu Azul Blue

ASSISE: TISSU AU CHOIX  
ASIENTO: TAPIZADO A ELEGIR  
UPHOLSTERED SEAT

Cf. page 508  
Ver pagina 508  
See page 508

# Plus

Siège ergonomique pourvu d'un mécanisme synchro de grande qualité lui conférant un excellent confort.

Silla ergonómica con mecanismo sincro de grandes prestaciones, posibilitando un mayor confort en el trabajo.

Ergonomic chair with synchro mechanism and high performance, providing a great comfort at workplaces.

| SIÈGE OPERATIF

| SILLA OPERATIVA

| TASK CHAIR



Réglable en hauteur  
Regulación altura  
Height adjustment

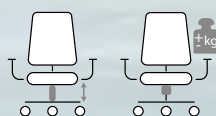

Support lombaire réglable  
Regulación lumbar  
Lumbar support adjustment

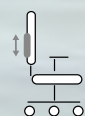

Accoudoirs réglables  
Regulación brazos  
Arms adjustment

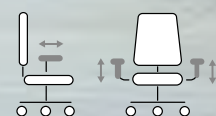

Assise réglable en profondeur  
Asiento regulable en profundidad  
Seat depth adjustment

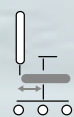

Mécanisme synchrone  
Mecanismo sincro  
Synchro mechanism







| SIÈGE OPÉRATIF AVEC  
| ACCOUDOIRS FIXES

| SILLA OPERATIVA CON  
| BRAZOS FIJOS

| TASK CHAIR WITH  
| FIXED ARMS

| VISITEUR  
| LUGE

| CONFIDENTE  
| BALANCÍN

| CANTILEVER  
| CHAIR



Support lombaire ajustable.  
Con regulación lumbar.  
With lumbar support adjustment.



## MODÈLES | VARIANTES | VERSIONS

MODÈLE / VARIANTES / VERSIONS	TYPE / TIPO / TYPE	RÉFÉRENCE / REFERENCIA / CODE	
 <p>Opératifs avec translation d'assise Operativa con traslo Task with seat depth adjustment</p>	Sans accoudoirs / Sin brazos / Without arms	136.301.-..	136.301.-..
	Accoudoirs fixes / Con brazos / Fixed arms	136.302.-..	136.302.-..
	Accoudoirs réglables / Brazos regulables / Adjustable arms	136.303.-..	136.303.-..

 <p>Opératifs Operativa Task</p>	Sans accoudoirs / Sin brazos / Without arms	136.001.-..	136.001.-..
	Accoudoirs fixes / Con brazos / Fixed arms	136.002.-..	136.002.-..
	Accoudoirs réglables / Brazos regulables / Adjustable arms	136.003.-..	136.003.-..

## FINITIONS | ACABADOS | FINISHES

BASE  
BASE  
BASE

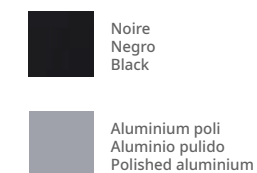

DOSSIER EN RÉVILLE  
RESPALDO EN REJILLA  
MESH BACKREST

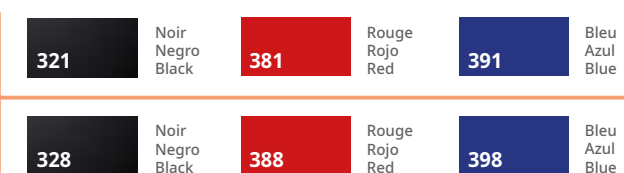

ASSISE: TISSU AU CHOIX  
ASIENTO: TAPIZADO A ELEGIR  
UPHOLSTERED SEAT

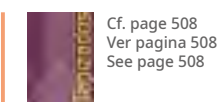

## MODÈLES | VARIANTES | VERSIONS

 <p>Luge Balancín Cantilever</p>	Sans accoudoirs / Sin brazos / Without arms	136.801.-..
	Accoudoirs fixes / Con brazos / Fixed arms	136.802.-..

## FINITIONS | ACABADOS | FINISHES

STRUCTURE  
ESTRUCTURA  
FRAME

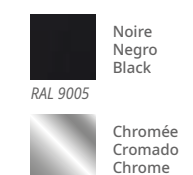

DOSSIER EN RÉVILLE  
RESPALDO EN REJILLA  
MESH BACKREST

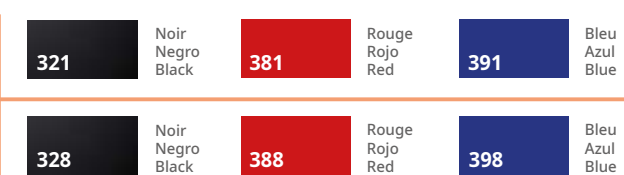

ASSISE: TISSU AU CHOIX  
ASIENTO: TAPIZADO A ELEGIR  
UPHOLSTERED SEAT

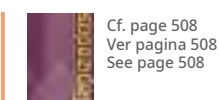

# Porto

Siège opératif avec présence et design actuel.  
Il dispose d'une grande variété de réglages qui lui permettent de s'adapter facilement aux besoins de chaque utilisateur.

Silla operativa con presencia y diseño actual.  
Tiene una gran variedad de movimientos y regulaciones que le permiten adaptarse fácilmente a las necesidades de cada usuario.

Task chair with presence and current design.  
It has a wide variety of movements and regulations that allow it to easily adapt to the needs of each user.

SIÈGE OPÉRATIF  
REMOURRÉ

SILLA OPERATIVA  
TAPIZADA

UPHOLSTERED  
TASK CHAIR

Réglable en hauteur  
Regulación altura  
Height adjustment

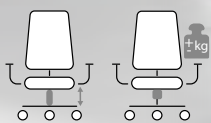

Support lombaire réglable  
Regulación lumbar  
Lumbar support adjustment

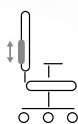

Accoudoirs réglables  
Regulación brazos  
Arms adjustment

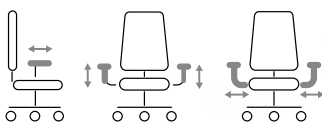

Assise réglable en profondeur  
Asiento regulable en profundidad  
Seat depth adjustment

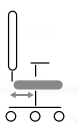

Mécanisme synchrone  
Mecanismo sincro  
Synchro mechanism





Support lombaire réglable.  
Regulación soporte lumbar.  
Lumbar support adjustment.



Réglage des accoudoirs.  
Regulación de brazos.  
Arms adjustment.

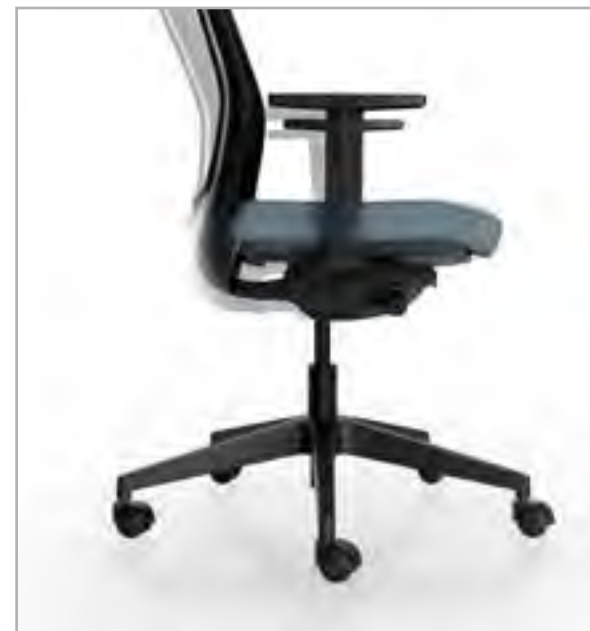

Mécanisme Synchrone.  
Mecanismo Syncro.  
Syncro Mechanism.



Accoudoirs 3d.  
Brazos regulables 3d.  
3d armrests adjustment.



Hauteur et profondeur de l'assise réglable.  
Altura y profundidad del asiento regulables.  
Seat height and depth adjustment.

## MODÈLES | VARIANTES | VERSIONS









MODÈLE / VARIANTES / VERSIONS	TYPE / TIPO / TYPE	RÉFÉRENCE / REFERENCIA / CODE
 <p>Opératifs avec translation d'assise Operativa con traslo Task with seat depth adjustment</p>	<p>Sans accoudoirs / Sin brazos / Without arms Accoudoirs réglables / Brazos regulables / Adjustable arms</p>	<p>172.001.-- 172.003.--</p>
 <p>Opératifs Operativa Task</p>	<p>Sans accoudoirs / Sin brazos / Without arms Accoudoirs réglables / Brazos regulables / Adjustable arms</p>	<p>172.031.-- 172.033.--</p>

## FINITIONS | ACABADOS | FINISHES

BASE + COQUE + ACCOUDOIRS  
BASE + CARCASA + BRAZOS  
BASE + SHELL + ARMS

DOSSIER EN RÉVILLE  
RESPALDO EN REJILLA  
MESH BACKREST

ASSISE: TISSU AU CHOIX  
ASIENTO: TAPIZADO A ELEGIR  
UPHOLSTERED SEAT

 Noir Negro Black	 327	 Noir Negro Black	 346	 Blanc Blanco White	 391	 Bleu Azul Blue	 344	 Gris Gris Grey
--	---	--	---	--	---	--	--	--

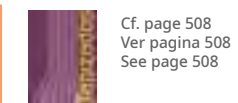

Cf. page 508  
Ver pagina 508  
See page 508



# Exagonus

Série de sièges aux multiples possibilités et combinaisons. Une nouvelle gamme de sièges design et confortable, dont les éléments structurels sont de grande qualité et résistance.

Silla operativa con contacto permanente, en donde la calidad de sus acabados y su ergonomía, nos confieren un bienestar y confort en nuestro hábitat de trabajo.

Office chair with permanent contact, that gives well being and comfort in the workspace thanks to its quality finishes and ergonomics.

| SIÈGE OPÉRATIF

| OPERATIVA

| TASK CHAIR



Réglable en hauteur  
Regulación altura  
Height adjustment

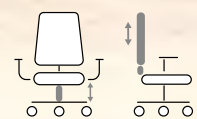

Support lombaire  
Soporte lumbar  
Lumbar support

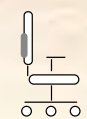

Accoudoirs réglables  
Regulación brazos  
Arms adjustment



Mécanisme de contact permanent  
Mecanismo de contacto permanente  
Permanent contact mechanism





| SIÈGE OPÉRATIF

| OPERATIVA

| TASK CHAIR

Dossier en tissu ou en résille.  
El respaldo puede ser tapizado o con rejilla.  
Available upholstered or mesh backrest.



Base noire ou blanche.  
La base puede ser negra o blanca.  
White or black 5-star base.

## MODÈLES | VARIANTES | VERSIONS

MODÈLE / VARIANTES / VERSIONS	TYPE / TIPO / TYPE	RÉFÉRENCE / REFERENCIA / CODE
	Sans accoudoirs / Sin brazos / Without arms	164.021.107
Opératifs Operativa Task	Accoudoirs réglables / Brazos regulables / Adjustable arms	164.023.107

## FINITIONS | ACABADOS | FINISHES

BASE  
BASE  
BASE

ASSISE ET DOSSIER: TISSU AU CHOIX  
ASIENTO Y RESPALDO: TAPIZADO A ELEGIR  
UPHOLSTERED SEAT AND BACKREST

 Noire  
Negro  
Black

 Cf. page 508  
Ver pagina 508  
See page 508

## MODÈLES | VARIANTES | VERSIONS

MODÈLE / VARIANTES / VERSIONS	TYPE / TIPO / TYPE	RÉFÉRENCE / REFERENCIA / CODE	RÉFÉRENCE / REFERENCIA / CODE
	Sans accoudoirs / Sin brazos / Without arms	164.021.327	164.721.326
Opératifs dossier en résille Operativa respaldo en rejilla Mesh backrest task chair	Accoudoirs réglables / Brazos regulables / Adjustable arms	164.023.327	164.723.326

## FINITIONS | ACABADOS | FINISHES

BASE  
BASE  
BASE

DOSSIER EN RÉVILLE  
RESPALDO EN REJILLA  
MESH BACKREST

ASSISE: TISSU AU CHOIX  
ASIENTO: TAPIZADO A ELEGIR  
UPHOLSTERED SEAT

 Noire  
Negro  
Black

 Noir  
Negro  
Black

 Cf. page 508  
Ver pagina 508  
See page 508

 Blanche  
Blanco  
White

 Blanc  
Blanco  
White





# Copa

Siège ergonomique équipé d'un mécanisme synchrone et bénéficiant d'un rapport qualité/prix exceptionnel.

Silla ergonómica de gran calidad con mecanismo Sincro. Rejilla disponible en múltiples acabados a un precio muy competitivo.

Good quality ergonomic chair with synchro mechanism. Backrest mesh available in a wide range of finishes and with an affordable price.

| SIÈGE OPÉRATIF

| OPERATIVA

| TASK CHAIR



Réglable en hauteur  
Regulación altura  
Height adjustment

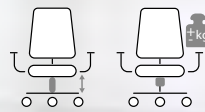

Support lombaire  
Soporte lumbar  
Lumbar support

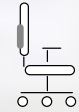

Accoudoirs réglables  
Regulación brazos  
Arms adjustment

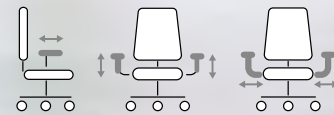

Assise réglable en profondeur  
Asiento regulable en profundidad  
Seat depth adjustment



Mécanisme synchrone  
Mecanismo sincro  
Synchro mechanism



| SIÈGE OPÉRATIF

| OPERATIVA

| TASK CHAIR



Accoudoirs 3D en option.  
Brazos opcionales con  
regulación 3D.  
Optional 3D adjustable arms.



Roulettes pour sol dur  
optionnelles.  
Ruedas blandas opcionales.  
Optional soft wheels.



## MODÈLES | VARIANTES | VERSIONS













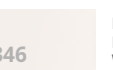



MODÈLE / VARIANTES / VERSIONS	TYPE / TIPO / TYPE	RÉFÉRENCE / REFERENCIA / CODE
	Sans accoudoirs / Sin brazos / Without arms	165.001.---
Opératifs avec translation d'assise Operativa con traslo Task with seat depth adjustment	Accoudoirs réglables / Brazos regulables / Adjustable arms	165.003.---
	Sans accoudoirs / Sin brazos / Without arms	165.031.---
	Accoudoirs réglables / Brazos regulables / Adjustable arms	165.033.---
	Sans accoudoirs / Sin brazos / Without arms	165.031.---
Opératifs Operativa Task		

## FINITIONS | ACABADOS | FINISHES

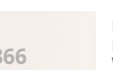
BASE + COQUE + ACCOUDOIRS  
BASE + CARCASA + BRAZOS  
BASE + SHELL + ARMS

DOSSIER EN RÉVILLE  
RESPALDO EN REJILLA  
MESH BACKREST

ASSISE: TISSU AU CHOIX  
ASIENTO: TAPIZADO A ELEGIR  
UPHOLSTERED SEAT

 Noir Negro Black	 327	 Noire Negro Black	 346	 Blanche Blanco White	 391	 Bleue Azul Blue	 344	 Grise Gris Grey
 Blanc Blanco White	 326	 Noire Negro Black	 366	 Blanche Blanco White	 365	 Bleue Azul Blue	 364	 Grise Gris Grey



Cf. page 508  
Ver pagina 508  
See page 508



# Logos

LOGOS a les bases d'un siège opératif avec dossier en résille noire et assise rembourrée noire. Il a un mécanisme synchrone et des accoudoirs réglables en hauteur.

LOGOS tiene los básicos de una silla operativa. Una silla con respaldo en rejilla negra y asiento tapizado en negro. Dispone de mecanismo síncro y brazos regulables en altura.

LOGOS is a basic chair with Black mesh backrest and Black upholstered seat. It has synchro mechanism and height adjustable arms as an option.

OPÉRATIF  
AVEC TÊTIÈRE

OPERATIVA  
CON CABEZAL

TASK CHAIR  
WITH HEADREST

Tête réglable  
Regulación cabezal  
Headrest adjustment

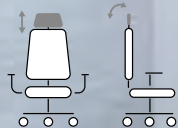

Réglable en hauteur  
Regulación altura  
Height adjustment

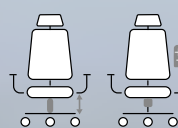

Accoudoirs réglables  
Regulación brazos  
Arms adjustment

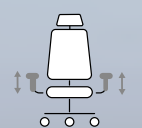

Mécanisme synchrone  
Mecanismo síncro  
Synchro mechanism

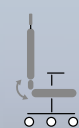

| SIÈGE OPÉRATIF

| SILLA OPERATIVA

| TASK CHAIR



Assise uniquement en tissu noir.  
Asiento tapizado exclusivamente en negro.  
Only black upholstered seat.

Réglable en hauteur  
Regulación altura  
Height adjustment

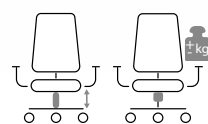

Accoudoirs réglables  
Regulación brazos  
Arms adjustment

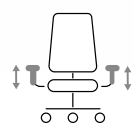

Mécanisme synchrone  
Mecanismo sincro  
Synchro mechanism

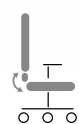

## MODÈLES | VARIANTES | VERSIONS

MODÈLE / VARIANTES / VERSIONS	TYPE / TIPO / TYPE	RÉFÉRENCE / REFERENCIA / CODE
 <p>Opératif avec tête Operativa con cabezal Task chair with headrest</p>	<p>Accoudoirs réglables / Brazos regulables / Adjustable arms</p>	<p>167.029.321</p>
 <p>Opératifs Operativa Task</p>	<p>Sans accoudoirs / Sin brazos / Without arms Accoudoirs réglables / Brazos regulables / Adjustable arms</p>	<p>167.301.329 167.003.321</p>

## FINITIONS | ACABADOS | FINISHES

BASE + RÉVILLE  
BASE + REJILLA  
BASE + MESH

 Noire  
Negro  
Black



# Iris

Le dossier en résille du siège IRIS est très confortable et disponible en coloris noir, rouge ou bleu. Cette série de sièges design est d'un grand confort.

La silla IRIS se caracteriza por su respaldo en malla muy confortable disponible en tres colores: negro, rojo o azul. Su punto fuerte es un asiento ancho realizado con una espuma que se adapta a todo tipo de usuario.

IRIS mesh backrest is very comfortable and it's available in three different finishes: black, red or blue. The seat is wide and its foam fits with any user.

| SIÈGE OPÉRATIF

| SILLA OPERATIVA

| TASK CHAIR



Réglable en hauteur  
Regulación altura  
Height adjustment



Accoudoirs réglables  
Regulación brazos  
Arms adjustment

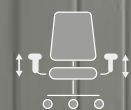

Mécanisme synchrone  
Mecanismo sincro  
Synchro mechanism





| SIÈGE OPÉRATIF

| SILLA OPERATIVA

| TASK CHAIR



| VISITEUR  
| LUGE

| CONFIDENTE  
| BALANCÍN

| CANTILEVER  
| CHAIR



Assise uniquement en tissu noir.  
Asiento tapizado exclusivamente en negro.  
Only black upholstered seat.



## MODÈLES | VARIANTES | VERSIONS

MODÈLE / VARIANTES / VERSIONS	TYPE / TIPO / TYPE	RÉFÉRENCE / REFERENCIA / CODE
	Sans accoudoirs / Sin brazos / Without arms	   Siège démonté / silla desmontada / unassembled chair 122.301.329 122.301.389 122.301.399 Siège monté / silla montada / assembled chair 122.301.321 122.301.381 122.301.391
		Opératifs Operativa Task Accoudoirs réglables / Brazos regulables / Adjustable arms Siège démonté / silla desmontada / unassembled chair 122.303.329 122.303.389 122.303.399 Siège monté / silla montada / assembled chair 122.303.321 122.303.381 122.303.391

## FINITIONS | ACABADOS | FINISHES

ASSISE  
ASIENTO  
UPHOLSTERED

BASE + RÉVILLE  
BASE + REJILLA  
BASE + MESH



Noire  
Negro  
Black



Noire + noire  
Negro + negro  
Black + black







Noire + rouge  
Negro + roja  
Black + red



Noire + bleue  
Negro + azul  
Black + blue

## MODÈLES | VARIANTES | VERSIONS

MODÈLE / VARIANTES / VERSIONS	TYPE / TIPO / TYPE	RÉFÉRENCE / REFERENCIA / CODE
	Sans accoudoirs / Sin brazos / Without arms	   Siège démonté / silla desmontada / unassembled chair 122.802.329 122.802.389 122.802.399 Siège monté / silla montada / assembled chair 122.802.321 122.802.381 122.802.391
		Luge Balancin Cantilever

## FINITIONS | ACABADOS | FINISHES

STRUCTURE  
ESTRUCTURA  
FRAME

ASSISE + RÉVILLE  
ASIENTO + REJILLA  
UPHOLSTERED + MESH



Chromée  
Cromado  
Chrome



Noir + noir  
Negro + negro  
Black + black



Noir + rouge  
Negro + roja  
Black + red



Noir + bleu  
Negro + azul  
Black + blue



# Lotus

SIÈGE OPÉRATIF

SILLA OPERATIVA

TASK CHAIR

Fauteuil basculant qui favorise le comportement postural du dos et prévient les lésions. Lotus est composé d'une assise rembourrée noire et d'un dossier en résille.

Silla reclinable con respaldo basculante que fomenta la relajación de la espalda y evita lesiones. Lotus se compone por un asiento tapizado en negro y un respaldo en rejilla.

Task chair with tilting back that encourages back relaxation and prevents injuries. Lotus consists of the seat upholstered in black and a mesh backrest.

Réglable en hauteur  
Regulación altura  
Height adjustment



Accoudoirs réglables  
Regulación brazos  
Arms adjustment

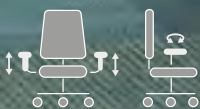

Mécanisme de contact permanent  
Mecanismo de contacto permanente  
Permanent contact mechanism





| SIÈGE OPÉRATIF

| SILLA OPERATIVA

| TASK CHAIR



| Accoudoirs réglables 2D.  
| Brazos regulables 2D.  
| 2D adjustable arms.

| Dossier en résille noire ou blanche.  
| Rejilla respaldo en negro o blanco.  
| Black or white backrest mesh.



## MODÈLES | VARIANTES | VERSIONS

MODÈLE / VARIANTES / VERSIONS	TYPE / TIPO / TYPE	RÉFÉRENCE / REFERENCIA / CODE
	Sans accoudoirs Sin brazos Without arms	Siège démonté / Silla desmontada / Unassembled chair Siège monté / Silla montada / Assembled chair 121.301.329    121.301.379 121.301.321    121.301.371
	Accoudoirs réglables Con brazos regulables With adjustable arms	Siège démonté / Silla desmontada / Unassembled chair Siège monté / Silla montada / Assembled chair 121.303.329    121.303.379 121.303.321    121.303.371

Opératifs  
Operativa  
Task

## FINITIONS | ACABADOS | FINISHES

BASE + ENJOLIVEURS  
BASE + EMBELLECEDORES  
BASE + BASE COVERS

 Noire + noir  
 Negro + negro  
 Black + black

 Noire + argenté  
 Negro + plata  
 Black + silver

RÉSILLE  
REJILLA  
MESH

 Noire  
 Negro  
 Black

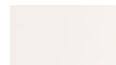
 Blanche  
 Blanco  
 White



SIÈGES DIRECTION  
DIRECCIÓN  
EXECUTIVE



146 | ELBA



152 | VIC



158 | CRETA



166 | TEOS



172 | ATOS



178 | EVOLE



186 | ROA

# Elba

| SIÈGE DE DIRECTION | SILLA DIRECCIÓN | EXECUTIVE CHAIR

Le siège ELBA est un complément idéal des bureaux de direction.

Choisissez la finition chromée ou argentée ainsi que le tissu qui s'adaptera le mieux à votre environnement de travail.

El sillón ELBA ofrece prestaciones de gama alta para adecuarse perfectamente en los despachos de dirección. Con la base en plata o cromada y la tela que mejor se integre en su entorno de trabajo.

ELBA chair is an exclusive chair for executive offices full of high quality details such as its base in chrome or silver finish or the wide range of fabrics and leather for upholstery it.



Réglable en hauteur  
Regulación altura  
Height adjustment

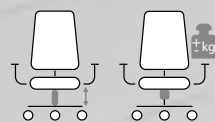

Mécanisme basculant  
Mecanismo basculante  
Knee tilting system

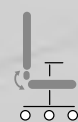

VISITEUR  
LUGE

CONFIDENTE  
BALANCÍN

CANTILEVER  
CHAIR

Accoudoirs fixes.  
Con brazos fijos.  
With "O-shape" upholstered fixed arms.



Structure chromée ou argentée.  
Estructura cromada o plata.  
Chrome or silver frame.



Réglable en hauteur  
Regulación altura  
Height adjustment

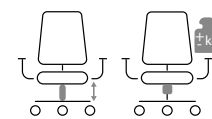

Mécanisme synchrone  
Mecanismo síncro  
Synchro mechanism

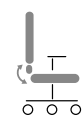

Siège très confortable.  
Se caracteriza por su comodidad.  
A very comfortable chair.







SIÈGE DIRECTION  
DOSSIER BAS

SILLA DIRECCIÓN  
RESPALDO BAJO

EXECUTIVE CHAIR  
LOW BACKREST

## MODÈLES | VARIANTES | VERSIONS

MODÈLE / VARIANTES / VERSIONS	TYPE / TIPO / TYPE	RÉFÉRENCE / REFERENCIA / CODE
	Barre torsion avec accoudoirs fixes / Barra de torsión con brazos fijos / Knee-tilt mechanism with fixed arms	52.522.105 52.522.109
	Basculant avec accoudoirs fixes / Basculante con brazos fijos / Tilt mechanism with fixed arms	52.422.105 52.422.109
<b>Direction</b> Dirección Executive		
	Barre torsion avec accoudoirs fixes / Barra de torsión con brazos fijos / Knee-tilt mechanism with fixed arms	52.512.105 52.512.109
	Basculant avec accoudoirs fixes / Basculante con brazos fijos / Tilt mechanism with fixed arms	52.412.105 52.412.109
<b>Direction - Dossier bas</b> Dirección - Respaldo bajo Executive - Low backrest		
		52.812.105 52.812.109
<b>Luge</b> Balancín Cantilever		

## FINITIONS | ACABADOS | FINISHES

STRUCTURE ET BASE  
ESTRUCTURA Y BASE  
FRAME AND BASE

Argentée  
Plata  
Silver  
RAL 9006

Chromée  
Cromado  
Chrome

ASSISE ET DOSSIER: TISSU AU CHOIX  
ASIENTO Y RESPALDO: TAPIZADO A ELEGIR  
UPHOLSTERED SEAT AND BACKREST

Cf. page 508  
Ver pagina 508  
See page 508





# Vic

Fauteuil de direction au design avant-gardiste.

Sillón direccional con un diseño clásico muy cómodo. Dispone de mecanismo síncro con ajuste de tensión y los brazos son fijos en acabado cromado.

Classic and comfortable executive chair with synchro mechanism with weight adjustment. Fixed arms with chrome details.

Réglable en hauteur  
Regulación altura  
Height adjustment

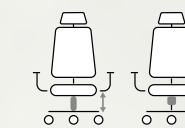

Mécanisme synchrone  
Mecanismo síncro  
Synchro mechanism



| SIÈGE DE DIRECTION | SILLA DIRECCIÓN | EXECUTIVE CHAIR

VISITEUR  
LUGE

CONFIDENTE  
BALANCÍN

CANTILEVER  
CHAIR

Structure chromée.  
Con estructura balancín cromada.  
Chrome cantilever frame.



Accoudoirs fixes et mécanisme synchrone.  
Silla con brazos fijos y mecanismo sincro.  
Synchro mechanism chair with fixed arms.

Réglable en hauteur  
Regulación altura  
Height adjustment

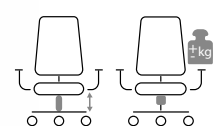

Mécanisme synchrone  
Mecanismo sincro  
Synchro mechanism

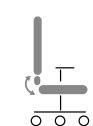



SIÈGE DIRECTION  
DOSSIER BAS

SILLA DIRECCIÓN  
RESPALDO BAJO

EXECUTIVE CHAIR  
LOW BACKREST

## MODÈLES | VARIANTES | VERSIONS

MODÈLE / VARIANTES / VERSIONS	TYPE / TIPO / TYPE	RÉFÉRENCE / REFERENCIA / CODE						
 <p>Direction Dirección Executive</p>	Accoudoirs fixes / Brazos fijos / Fixed arms	<table border="0"> <tr> <td>Siège démonté / silla desmontada / unassembled chair</td> <td>129.426.198</td> <td>129.426.188</td> </tr> <tr> <td>Siège monté / silla montada / assembled chair</td> <td>129.426.191</td> <td>129.426.181</td> </tr> </table>	Siège démonté / silla desmontada / unassembled chair	129.426.198	129.426.188	Siège monté / silla montada / assembled chair	129.426.191	129.426.181
	Siège démonté / silla desmontada / unassembled chair	129.426.198	129.426.188					
Siège monté / silla montada / assembled chair	129.426.191	129.426.181						
 <p>Direction - Dossier bas Dirección - Respaldo bajo Executive - Low backrest</p>	Accoudoirs fixes / Brazos fijos / Fixed arms	<table border="0"> <tr> <td>Siège démonté / silla desmontada / unassembled chair</td> <td>129.402.198</td> <td>129.402.188</td> </tr> <tr> <td>Siège monté / silla montada / assembled chair</td> <td>129.402.191</td> <td>129.402.181</td> </tr> </table>	Siège démonté / silla desmontada / unassembled chair	129.402.198	129.402.188	Siège monté / silla montada / assembled chair	129.402.191	129.402.181
	Siège démonté / silla desmontada / unassembled chair	129.402.198	129.402.188					
Siège monté / silla montada / assembled chair	129.402.191	129.402.181						

## FINITIONS | ACABADOS | FINISHES

BASE + TISSU  
BASE + TAPIZADO  
BASE + UPHOLSTERED

Aluminium poli + Simili cuir noir  
Aluminio pulido + PU negra  
Polished aluminium + Black imitation leather

Aluminium poli + Cuir noir  
Aluminio pulido + Piel negra  
Polished aluminium + Black leather

## MODÈLES | VARIANTES | VERSIONS

 <p>Luge Balancín Cantilever</p>	Accoudoirs fixes / Brazos fijos / Fixed arms	<table border="0"> <tr> <td>Siège monté / silla montada / assembled chair</td> <td>129.802.191</td> <td>129.802.181</td> </tr> <tr> <td>4 Sièges démontés / 4 sillas desmontadas / 4 unassembled chairs</td> <td>129.802.194</td> <td>129.802.184</td> </tr> </table>	Siège monté / silla montada / assembled chair	129.802.191	129.802.181	4 Sièges démontés / 4 sillas desmontadas / 4 unassembled chairs	129.802.194	129.802.184
	Siège monté / silla montada / assembled chair	129.802.191	129.802.181					
4 Sièges démontés / 4 sillas desmontadas / 4 unassembled chairs	129.802.194	129.802.184						

## FINITIONS | ACABADOS | FINISHES

STRUCTURE + TISSU  
ESTRUCTURA + TAPIZADO  
FRAME + UPHOLSTERED

Chromée + Simil cuir noir  
Cromado + PU negra  
Chrome + Black imitation leather

Chromée + Cuir noir  
Cromado + Piel negra  
Chrome + Black leather



# Creta

| SIÈGE DE DIRECTION | SILLA DIRECCIÓN | EXECUTIVE CHAIR

Siège polyvalent disponible en modèle direction, opératif ou avec un piètement luge, très confortable.

Sillón polivalente que permite su uso direccional y operativo de altas prestaciones de confort.

CRETA chair is very comfortable and can either meet executive or office uses.



Réglable en hauteur  
Regulación altura  
Height adjustment

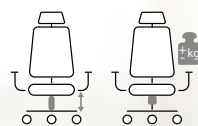

Accoudoirs réglables  
Regulación brazos  
Arms adjustment

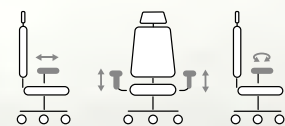

Mécanisme synchrone  
Mecanismo sincro  
Synchro mechanism



SIÈGE DIRECTION  
DOSSIER BAS

SILLA DIRECCIÓN  
RESPALDO BAJO

EXECUTIVE CHAIR  
LOW BACKREST

Accoudoirs réglables et mécanisme synchrone.  
Brazos regulables y mecanismo síncro.  
Synchro mechanism chair with adjustable arms.



Réglable en hauteur  
Regulación altura  
Height adjustment

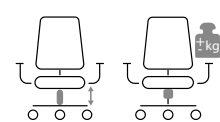

Accoudoirs réglables  
Regulación brazos  
Arms adjustment

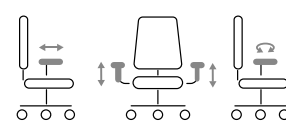

Mécanisme synchrone  
Mecanismo síncro  
Synchro mechanism

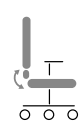

Sièges en simili cuir ou en cuir noir.  
Puede estar tapizada con piel o polipiel.  
Can be upholstered in leather or PU leather.

Idéal pour donner une touche élégante à votre bureau.  
Ideal para ambientes elegantes.  
Give and elegant touch to the office with this chair.



| VISITEUR  
| LUGE

| CONFIDENTE  
| BALANCÍN

| CANTILEVER  
| CHAIR



| Visiteur luge avec structure chromée.  
| Con estructura balancín cromada.  
| Chrome cantilever frame.

## MODÈLES | VARIANTES | VERSIONS

MODÈLE / VARIANTES / VERSIONS	TYPE / TIPO / TYPE	RÉFÉRENCE / REFERENCIA / CODE
 <p>Accoudoirs réglables / Brazos regulables / Adjustable arms</p> <p>Direction Dirección Executive</p>	Siège démonté / silla desmontada / unassembled chair	128.327.198 128.327.188
	Siège monté / silla montada / assembled chair	128.327.191 128.327.181
 <p>Accoudoirs réglables / Brazos regulables / Adjustable arms</p> <p>Direction - Dossier bas Dirección - Respaldo bajo Executive - Low backrest</p>	Siège démonté / silla desmontada / unassembled chair	128.303.198 128.303.188
	Siège monté / silla montada / assembled chair	128.303.191 128.303.181

## FINITIONS | ACABADOS | FINISHES

BASE + TISSU  
BASE + TAPIZADO  
BASE + UPHOLSTERED

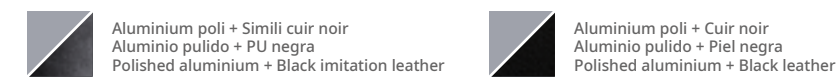

## MODÈLES | VARIANTES | VERSIONS

 <p>Accoudoirs fixes / Brazos fijos / Fixed arms</p> <p>Luge Balancín Cantilever</p>	Siège monté / silla montada / assembled chair	128.802.191 128.802.181
	4 Sièges démontés / 4 sillas desmontadas / 4 unassembled chairs	128.802.194 128.802.184

## FINITIONS | ACABADOS | FINISHES

STRUCTURE + TISSU  
ESTRUCTURA + TAPIZADO  
FRAME + UPHOLSTERED

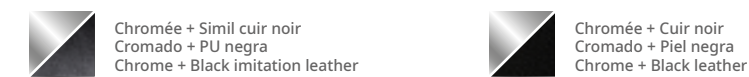

# Teos

Ce fauteuil de direction est défini par un design sobre, sans ornements. L'incorporation du mécanisme synchro favorise le confort postural et améliore l'ergonomie pour ceux qui passent de longues heures assis.

Un diseño sobrio y sin ornamentos definen este sillón direccional. La incorporación del mecanismo sincro favorece el confort postural y mejora la ergonomía para quienes están largas horas sentados.

A serious and austere design defines this directional armchair. The synchro mechanism favors postural comfort and improves ergonomics for those who are sitting on this excellent executive chair.



Réglable en hauteur  
Regulación altura  
Height adjustment

Mécanisme synchrone  
Mecanismo sincro  
Synchro mechanism

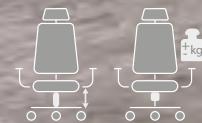

| SIÈGE DE DIRECTION | SILLA DIRECCIÓN | EXECUTIVE CHAIR



Tête et dossier fixe.  
Cabezal y respaldo fijo.  
Fixed headrest and backrest.



Dossier bas.  
Respaldo bajo.  
Fixed low.



Réglable en hauteur  
Regulación altura  
Height adjustment

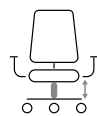

## MODÈLES | VARIANTES | VERSIONS

MODÈLE / VARIANTES / VERSIONS	TYPE / TIPO / TYPE	RÉFÉRENCE / REFERENCIA / CODE			
 <p>Direction Dirección Executive</p>	Siège démonté / silla desmontada / unassembled chair	168.426.198	168.426.188	168.426.199	168.426.189
	Siège monté / silla montada / assembled chair	168.426.191	168.426.181	168.426.192	168.426.182

MODÈLE / VARIANTES / VERSIONS	TYPE / TIPO / TYPE	RÉFÉRENCE / REFERENCIA / CODE			
 <p>Direction - Dossier bas Dirección - Respaldo bajo Executive - Low backrest</p>	Siège démonté / silla desmontada / unassembled chair	168.802.198	168.802.188	168.802.199	168.802.189
	Siège monté / silla montada / assembled chair	168.802.191	168.802.181	168.802.192	168.802.182

## FINITIONS | ACABADOS | FINISHES

BASE + TISSU  
BASE + TAPIZADO  
BASE + UPHOLSTERED

Aluminium poli + Simili cuir noir  
Aluminio pulido + PU negra  
Polished aluminium + Black imitation leather

Aluminium poli + Cuir noir  
Aluminio pulido + Piel negra  
Polished aluminium + Black leather

Chromée + Simil cuir gris  
Cromado + PU gris  
Chrome + Grey PU leather

Chromée + Cuir gris  
Cromado + Piel gris  
Chrome + Grey leather



# Atos

| SIÈGE DE DIRECTION | SILLA DIRECCIÓN | EXECUTIVE CHAIR

Fauteuil d'aspect léger et de design minimaliste. L'accoudoir s'envole, apportant dynamisme aux bureaux de direction.

Silla de aspecto ligero y diseño minimalista. El reposabrazos vuela aportando velocidad y dinamismo a los despachos de dirección.

Slight looking chair and minimalist design. Straight lines and wing-shaped armrests bringing speed and dynamism to the management office.



Réglable en hauteur  
Regulación altura  
Height adjustment

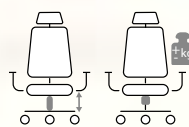

Mécanisme basculant  
Mecanismo basculante  
Knee tilting system

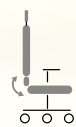



SIÈGE DIRECTION  
DOSSIER BAS

SILLA DIRECCIÓN  
RESPALDO BAJO

EXECUTIVE CHAIR  
LOW BACKREST



Giratoire sur patins.  
Giratoria con topes.  
Swivel chair with glides.

Réglable en hauteur  
Regulación altura  
Height adjustment



# MODÈLES | VARIANTES | VERSIONS

MODÈLE / VARIANTES / VERSIONS	TYPE / TIPO / TYPE	RÉFÉRENCE / REFERENCIA / CODE
 <p>Direction Dirección Executive</p>	<p>Accoudoirs fixes / Brazos fijos / Fixed arms</p>	<p>169.522.191 169.522.181 169.522.192 169.522.182</p>
 <p>Direction - Dossier bas Dirección - Respaldo bajo Executive - Low backrest</p>	<p>Accoudoirs fixes / Brazos fijos / Fixed arms</p>	<p>169.802.191 169.802.181 169.802.192 169.802.182</p>

# FINITIONS | ACABADOS | FINISHES

BASE + TISSU  
BASE + TAPIZADO  
BASE + UPHOLSTERED

- 

Aluminium poli + Simili cuir noir  
Aluminio pulido + PU negra  
Polished aluminium + Black imitation leather
- 

Aluminium poli + Cuir noir  
Aluminio pulido + Piel negra  
Polished aluminium + Black leather
- 

Aluminium poli + Simil cuir gris  
Aluminio pulido + PU gris  
Polished aluminium + Grey PU leather
- 

Aluminium poli + Cuir gris  
Aluminio pulido + Piel gris  
Polished aluminium + Grey leather



# Evoles

Sièges polyvalents disponibles en plusieurs versions pour vos espaces de travail. Son design d'avant-garde le rend actuel mais sans renoncer pour autant à la fonctionnalité.

Sillas polivalentes que abarcan diferentes propuestas dentro de nuestro espacio de trabajo. Su diseño vanguardista le confiere una imagen actual sin renunciar por ello a su funcionalidad.

Multipurpose office chair that cover different proposals of the workspace. The avant-garde design confers an actual image without renouncing its functionality.

SIÈGE DE DIRECTION  
REMOURRÉ

SILLA DIRECCIÓN  
TAPIZADA

UPHOLSTERED  
EXECUTIVE CHAIR



Réglable en hauteur  
Regulación altura  
Height adjustment



Mécanisme basculant  
Mecanismo basculante  
Knee tilting system



SIÈGE DE  
DIRECTION  
AVEC RÉSILLE

DIRECCIÓN  
CON REJILLA



Réglable en hauteur  
Regulación altura  
Height adjustment

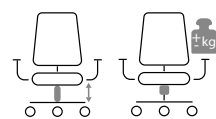

Mécanisme basculant  
Mecanismo basculante  
Knee tilting system

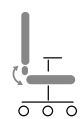

Résille blanche ou noire.  
Rejilla disponible en blanco o negro.  
Black or white mesh.

MESH  
EXECUTIVE  
CHAIR

SIÈGE AVEC  
RÉSILLE

SILLA CON  
REJILLA

MESH SWIVEL  
CHAIR





SIÈGE  
REMOURRÉ  
SUR PATINS

GIRATORIA  
TAPIZADA  
CON TOPES

UPHOLSTERED  
SWIVEL CHAIR  
WITH GLIDES

Accoudoirs fixes chromés.  
Brazos cromados fijos.  
With chrome fixed arms.





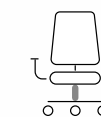



Réglable en hauteur  
Regulación altura  
Height adjustment





## MODÈLES | VARIANTES | VERSIONS

MODÈLE / VARIANTES / VERSIONS	TYPE / TIPO / TYPE	RÉFÉRENCE / REFERENCIA / CODE	
	Assise et dossier en tissu / Asiento y respaldo tapizados / Uphostered seat and backrest	 131.422.199	 131.422.099
	Assise et dossier en résille / Asiento y respaldo en rejilla / Mesh seat and backrest	131.422.329	131.422.089
Direction Dirección Executive			
	Assise et dossier en tissu / Asiento y respaldo tapizados / Uphostered seat and backrest	131.802.191	131.802.091
	Assise et dossier en résille / Asiento y respaldo en rejilla / Mesh seat and backrest	131.802.321	131.802.081
Base pyramidale plate sur patins Giratoria base plana con topes Flat crossed base with glides			

## FINITIONS | ACABADOS | FINISHES

BASE  
BASE  
BASE



Chromée  
Cromado  
Chrome

TISSU OU RÉVILLE  
TAPIZADO O REJILLA  
UPHOSTERED OR MESH

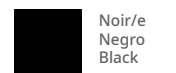

Noir/e  
Negro  
Black

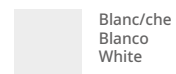

Blanc/che  
Blanco  
White



# Roa

Classique, volumineux et avec des caractéristiques de haute qualité et de confort. ROA, se connecte aux bureaux de gestion avec l'histoire et avec un parcours sans perdre l'ergonomie.

Clásica, rimbombante y con altas prestaciones de calidad y confort. ROA, conecta con despachos de dirección con historia y con recorrido sin perder ergonomía.

Classic, bold and with high quality and comfort. ROA, executive chair, fits well in management offices with history and prestige keeping its ergonomics.



| SIÈGE DIRECTION | SILLA DIRECCIÓN | EXECUTIVE CHAIR



Mécanisme basculant avec tension réglable selon poids.  
Mecanismo basculante con ajuste de tensión.  
Tilt mechanism with tension control to suit body weight.

Réglable en hauteur  
Regulación altura  
Height adjustment

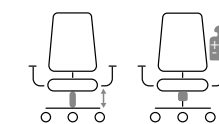

Mécanisme basculant  
Mecanismo basculante  
Knee tilting system

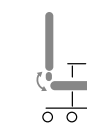

| VISITEUR  
LUGE

| CONFIDENTE  
BALANCÍN

| CANTILEVER  
CHAIR



Visiteur luge avec structure chromée.  
Con estructura balancín cromada.  
Chrome cantilever frame.







## MODÈLES | VARIANTES | VERSIONS

MODÈLE / VARIANTES / VERSIONS	TYPE / TIPO / TYPE	RÉFÉRENCE / REFERENCIA / CODE				
 Direction Dirección Executive	Accoudoirs fixes / Brazos fijos / Fixed arms	1 U. / 1 U. / 1 chair	127.426.371	127.426.171	127.426.191	127.426.181
		4 U. / 4 U. / 4 chairs	127.426.378	127.426.178	127.426.198	127.426.188

## FINITIONS | ACABADOS | FINISHES

BASE + TISSU  
 BASE + TAPIZADO  
 BASE + UPHOLSTERED





	Aluminium poli + Simil cuir beige Aluminio pulido + PU beige Polished aluminium + Beige imitation leather		Aluminium poli + Cuir beige Aluminio pulido + Piel beige Polished aluminium + Beige leather
	Aluminium poli + Simil cuir noire Aluminio pulido + PU negra Polished aluminium + Black imitation leather		Aluminium poli + Cuir noire Aluminio pulido + Piel negra Polished aluminium + Black leather

## MODÈLES | VARIANTES | VERSIONS

 Opératifs Operativa Task	Accoudoirs fixes / Brazos fijos / Fixed arms	1 U. / 1 U. / 1 chair	127.802.371	127.802.171	127.802.191	127.802.181
		4 U. / 4 U. / 4 chairs	127.802.379	127.802.179	127.802.199	127.802.189

## FINITIONS | ACABADOS | FINISHES

STRUCTURE + TISSU  
 ESTRUCTURA+ TAPIZADO  
 FRAME + UPHOLSTERED

	Chromée + Simil cuir beige Cromado + PU beige Chrome + Beige imitation leather		Chromée + Cuir beige Cromado + Piel beige Chrome + Beige leather
	Chromée + Simil cuir noire Cromado + PU negra Chrome + Black imitation leather		Chromée + Cuir noire Cromado + Piel negra Chrome + Black leather



CONTRACT  
CONTRACT  
CONTRACT



196 | MORK



206 | MINDY



216 | FRILL



226 | NO-FRILL



236 | NUT



240 | HOLE



246 | HOP



254 | LINER

# MORK

Au design universel italien, les chaises MORK appartiennent à la famille Contract. Les points forts de cette série sont une grande variété de couleurs et de structures qui permettent de répondre à vos besoins les plus exigeants. Monocoque large aux lignes droites et dossier courbe. MORK est complémentaire de MINDY.

El diseño italiano es un referente universal. Esta serie forma parte de la familia Contract en la que la variedad de colores y estructuras es el punto fuerte para poder adaptarse al máximo a todas las opciones donde se requiera un mobiliario de estas características. MORK es la pareja ideal de MINDY. Su monocarcasa es ancha y de formas lineales.

Italian design is a universal referral. This range belong to Contract chairs. A wide range of colors and frames are available to reach the most demanding expectation of the costumer. MORK is MINDY fiancé. Its shell is wide and with straight lines.

Empilable  
Apilable  
Stackable



CHAISE  
PIÈTEMENT  
TRAÎNEAU

SILLA CON  
ESTRUCTURA  
PATÍN

SLED FRAME  
CHAIR

Les finitions des structures 4 pieds  
et traîneaux peuvent être blanches,  
graphites ou chromées.

La estructura de 4 patas o patín puede  
ser en acabado blanco, grafito o  
cromado.

Four legs or sled frame can be in white,  
graphite or chrome finish.

Empilable  
Apilable  
Stackable





CHAISE GIRATOIRE  
AVEC BASE  
PYRAMIDALE  
SUR PATINS

GIRATORIA  
PIRAMIDAL  
CON TOPES

PYRAMIDAL  
SWIVEL CHAIR  
WITH GLIDES

Assise avec placet rembourré.  
El asiento puede tapizarse.  
Upholstered seat available.



Bases pyramidales et plates en aluminium poli. Chaise pivotante à 360° avec un système de retour automatique.

Tanto la base plana como la piramidal son de aluminio pulido con sistema autoretorno y rotación de 360°.

Polished aluminium swivel bases have 360° self-rotation system.



CHAISE GIRATOIRE  
AVEC BASE PLATE  
SUR PATINS

GIRATORIA  
PLANA CON  
TOPES

4-STAR SWIVEL  
CHAIR WITH GLIDES

CHAISE GIRATOIRE  
SUR ROULETTES

GIRATORIA  
CON RUEDAS

SWIVEL CHAIR  
WITH WHEELS

Selon la finition de la structure, le bouton décoratif du dossier sera blanc, graphite ou bleu.

El botón decorativo del respaldo puede ser blanco, grafito o azul y es muy útil para colgar objetos que así lo requieran.

The decorative bottom of the backrest is available in white, graphite or blue finishes and it's very useful for hanging objects.



Réglage en hauteur  
Regulación altura  
Height adjustment









| CHAISE 4 PIEDS    | SILLA CON 4 PATAS    | 4 LEGS CHAIR





Empilable jusqu'à 6 unités.  
Apilable hasta 6 unidades.  
Stackable up to 6 chairs.

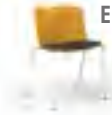

## MODÈLES | VARIANTES | VERSIONS

MODÈLE / VARIANTES / VERSIONS	TYPE / TIPO / TYPE	RÉFÉRENCE / REFERENCIA / CODE		
 C	Assise et dossier: en polypropylène Asiento y respaldo: en polipropileno Polypropylene seat and backrest	 157.271.-.-	 157.371.-.-	 157.471.-.-
 E	Assise: Tissu au choix. Dossier: en polypropylène Asiento: Tapizado a elegir. Respaldo: en polipropileno Upholstered seat. Polypropylene backrest	157.271.-.-	157.371.-.-	157.471.-.-





**Chaise 4 pieds**  
**Silla de 4 patas**  
**4 legs**

 C	Assise et dossier: en polypropylène Asiento y respaldo: en polipropileno Polypropylene seat and backrest	157.291.-.-	157.391.-.-	157.491.-.-
 E	Assise: Tissu au choix. Dossier: en polypropylène Asiento: Tapizado a elegir. Respaldo: en polipropileno Upholstered seat. Polypropylene backrest	157.291.-.-	157.391.-.-	157.491.-.-

**Chaise avec pieds traîneau**  
**Sillas patin**  
**Sled frame**

MODÈLE / VARIANTES / VERSIONS	TYPE / TIPO / TYPE	RÉFÉRENCE / REFERENCIA / CODE		
 C	Assise et dossier: en polypropylène Asiento y respaldo: en polipropileno Polypropylene seat and backrest	 157.511.-.-		
 E	Assise: Tissu au choix. Dossier: en polypropylène Asiento: Tapizado a elegir. Respaldo: en polipropileno Upholstered seat. Polypropylene backrest	157.511.-.-		

**Giratoire sur roulettes**  
**Giratoria con ruedas**  
**Swivel base with wheels**

 C	Assise et dossier: en polypropylène Asiento y respaldo: en polipropileno Polypropylene seat and backrest	Pyramidale / Piramidal / Pyramidal	 157.521.-.-	 157.501.-.-
 E	Assise: Tissu au choix. Dossier: en polypropylène Asiento: Tapizado a elegir. Respaldo: en polipropileno Upholstered seat. Polypropylene backrest	Plate / Plana / 4 Stars	157.521.-.-	157.501.-.-

**Chaise giratoire sur patins**  
**Silla giratoria con conteras**  
**Swivel base with glides**

## FINITIONS | ACABADOS | FINISHES

### STRUCTURE + BOUTON DOSSIER ESTRUCTURA + BOTON RESPALDO FRAME + BACKREST BUTTON

 Blanche + blanc  
Blanco + blanco  
White + white

 Graphite + graphite  
Grafito + grafito  
Graphite + graphite

 Chromée + bleu  
Cromado + azul  
Chrome + blue

### TYPE TIPO TYPE

### ASSISE ET DOSSIER: POLYPROPYLÈNE ASIENTO Y RESPALDO: POLIPROPILENO POLYPROPYLENE SEAT AND BACKREST

 241 Marron / Marrón / Beige

 281 Graphite / Grafito / Graphite

 251 Violet / Violeta / Violet

 221 Bleu clair / Azul claro / Light blue

 271 Bleu foncé / Azul claro / Dark blue

 231 Vert clair / Verde claro / Light green

 201 Orange / Naranja / Orange

### TYPE TIPO TYPE

### DOSSIER EN POLYPROPYLÈNE RESPALDO EN POLIPROPILENO POLYPROPYLENE BACKREST

 841 Marron / Marrón / Beige

 881 Graphite / Grafito / Graphite

 851 Violet / Violeta / Violet

 821 Bleu clair / Azul claro / Light blue

 871 Bleu foncé / Azul claro / Dark blue

 831 Vert clair / Verde claro / Light green

 801 Orange / Naranja / Orange

### ASSISE: TISSU AU CHOIX ASIENTO: TAPIZADO A ELEGIR UPHOLSTERED SEAT

 Cf. page 508  
Ver pagina 508  
See page 508

## FINITIONS | ACABADOS | FINISHES

### BASE + BOUTON DOSSIER BASE + BOTON RESPALDO BASE + BACKREST BUTTON

 Aluminium poli + bleu  
Aluminio pulido + azul  
Polished aluminium + blue

### TYPE TIPO TYPE

### ASSISE ET DOSSIER: POLYPROPYLÈNE ASIENTO Y RESPALDO: POLIPROPILENO POLYPROPYLENE SEAT AND BACKREST

 241 Marron / Marrón / Beige

 281 Graphite / Grafito / Graphite

 251 Violet / Violeta / Violet

 221 Bleu clair / Azul claro / Light blue

 271 Bleu foncé / Azul claro / Dark blue

 231 Vert clair / Verde claro / Light green

 201 Orange / Naranja / Orange

### TYPE TIPO TYPE

### DOSSIER EN POLYPROPYLÈNE RESPALDO EN POLIPROPILENO POLYPROPYLENE BACKREST

 841 Marron / Marrón / Beige

 881 Graphite / Grafito / Graphite

 851 Violet / Violeta / Violet

 821 Bleu clair / Azul claro / Light blue

 871 Bleu foncé / Azul claro / Dark blue

 831 Vert clair / Verde claro / Light green

 801 Orange / Naranja / Orange

### ASSISE: TISSU AU CHOIX ASIENTO: TAPIZADO A ELEGIR UPHOLSTERED SEAT

 Cf. page 508  
Ver pagina 508  
See page 508

# MINDY

De design universel italien, les chaises MINDY appartiennent à la famille Contract. Les points forts de cette série sont une grande variété de couleurs et de structures qui permettent de répondre à vos besoins les plus exigeants. Monocoque aux formes arrondies et munie d'un dossier étroit. MINDY est complémentaire de MORK.

El diseño italiano es un referente universal. Esta serie forma parte de la familia Contract en la que la variedad de colores y estructuras es el punto fuerte para poder adaptarse al máximo a todas las opciones donde se requiera un mobiliario de estas características. MINDY es la pareja ideal de MORK. Su monocarcasa tiene formas más redondeadas y el respaldo es más estrecho.

Italian design is a universal referral. This range belong to Contract chairs. A wide range of colors and frames are available to reach the most demanding expectation of the costumer. MINDY is MORK'S fiancée. Its shell is more tight and round.

Empilable  
Apilable  
Stackable



CHAISE  
PIÈTEMENT  
TRAÎNEAU

SILLA CON  
ESTRUCTURA  
PATÍN

SLED FRAME  
CHAIR



Empilable jusqu'à 6 unités.  
Apilable hasta 6 unidades.  
Stackable up to 6 chairs.



CHAISE GIRATOIRE  
SUR ROULETTES

GIRATORIA  
CON RUEDAS

SWIVEL CHAIR  
WITH WHEELS

Réglage en hauteur  
Regulación altura  
Height adjustment

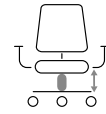

Selon la finition de la structure, le bouton décoratif du dossier sera blanc, graphite ou bleu.

El botón decorativo del respaldo puede ser blanco, grafito o azul y es muy útil para colgar objetos que así lo requieran.

The decorative bottom of the backrest is available in white, graphite or blue finishes and it's very useful for hanging objects.



Assise avec placet rembourré.  
El asiento puede tapizarse.  
Upholstered seat available.

CHAISE GIRATOIRE  
AVEC BASE PLATE  
SUR PATINS

GIRATORIA  
PLANA CON  
TOPES

4-STAR SWIVEL CHAIR  
WITH GLIDES



Bases pyramidales et plates en aluminium poli. Chaise pivotante à 360° avec un système de retour automatique.  
Tanto la base plana como la piramidal son de aluminio pulido con sistema autoretorno y rotación de 360°  
Polished aluminium swivel bases have 360° self-rotation system.

CHAISE GIRATOIRE  
AVEC BASE  
PYRAMIDALE  
SUR PATINS

GIRATORIA  
PIRAMIDAL  
CON TOPES

PYRAMIDAL  
SWIVEL CHAIR  
WITH GLIDES



| CHAISE 4 PIEDS

| SILLA CON 4 PATAS

| 4 LEGS CHAIR







Les finitions des structures 4 pieds et traîneau peuvent être blanches, graphites ou chromées.  
La estructura de 4 patas o patín puede ser en acabado blanco, grafito o cromado.  
Four legs or sled frame can be in white, graphite or chrome finish.



Empilable  
Apilable  
Stackable





# MODÈLES | VARIANTES | VERSIONS

MODÈLE / VARIANTES / VERSIONS	TYPE / TIPO / TYPE	RÉFÉRENCE / REFERENCIA / CODE		
 C	Assise et dossier: en polypropylène Asiento y respaldo: en polipropileno Polypropylene seat and backrest	 158.271.-...	 158.371.-...	 158.471.-...
 E	Assise: Tissu au choix. Dossier: en polypropylène Asiento: Tapizado a elegir. Respaldo: en polipropileno Upholstered seat. Polypropylene backrest	158.271.-...	158.371.-...	158.471.-...





**Chaise 4 pieds**  
**Silla de 4 patas**  
**4 legs**

 C	Assise et dossier: en polypropylène Asiento y respaldo: en polipropileno Polypropylene seat and backrest	158.291.-...	158.391.-...	158.491.-...
 E	Assise: Tissu au choix. Dossier: en polypropylène Asiento: Tapizado a elegir. Respaldo: en polipropileno Upholstered seat. Polypropylene backrest	158.291.-...	158.391.-...	158.491.-...

**Chaise avec pieds traîneau**  
**Sillas patin**  
**Sled base**

MODÈLE / VARIANTES / VERSIONS	TYPE / TIPO / TYPE	RÉFÉRENCE / REFERENCIA / CODE	
 C	Assise et dossier: en polypropylène Asiento y respaldo: en polipropileno Polypropylene seat and backrest		158.511.-...
 E	Assise: Tissu au choix. Dossier: en polypropylène Asiento: Tapizado a elegir. Respaldo: en polipropileno Upholstered seat. Polypropylene backrest		158.511.-...

**Giratoire sur roulettes**  
**Giratoria con ruedas**  
**Swivel base with wheels**

 C	Assise et dossier: en polypropylène Asiento y respaldo: en polipropileno Polypropylene seat and backrest	 Pyramidale / Piramidal / Pyramidal	 Plate / Plana / 4 Stars
 E	Assise: Tissu au choix. Dossier: en polypropylène Asiento: Tapizado a elegir. Respaldo: en polipropileno Upholstered seat. Polypropylene backrest	158.521.-...	158.501.-...

**Chaise giratoire sur patins**  
**Silla giratoria con conteras**  
**Swivel base with glides**

# FINITIONS | ACABADOS | FINISHES

STRUCTURE + BOUTON DOSSIER  
ESTRUCTURA + BOTÓN RESPALDO  
FRAME + BACKREST BUTTON

-  Blanche + blanc  
Blanco + blanco  
White + white
-  Graphite + graphite  
Grafito + grafito  
Graphite + graphite
-  Chromée + bleu  
Cromado + azul  
Chrome + blue

TYPE TIPO TYPE	C	ASSISE ET DOSSIER: POLYPROPYLÈNE ASIENTO Y RESPALDO: POLIPROPILENO POLYPROPYLENE SEAT AND BACKREST
TYPE TIPO TYPE	E	DOSSIER EN POLYPROPYLÈNE RESPALDO EN POLIPROPILENO POLYPROPYLENE BACKREST

**ASSISE: TISSU AU CHOIX  
ASIENTO: TAPIZADO A ELEGIR  
UPHOLSTERED SEAT**

**Cf. page 508  
Ver pagina 508  
See page 508**

# FINITIONS | ACABADOS | FINISHES

BASE + BOUTON DOSSIER  
BASE + BOTÓN RESPALDO  
BASE + BACKREST BUTTON

-  Aluminium poli + bleu  
Aluminio pulido + azul  
Polished aluminium + blue

TYPE TIPO TYPE	C	ASSISE ET DOSSIER: POLYPROPYLÈNE ASIENTO Y RESPALDO: POLIPROPILENO POLYPROPYLENE SEAT AND BACKREST
TYPE TIPO TYPE	E	DOSSIER EN POLYPROPYLÈNE RESPALDO EN POLIPROPILENO POLYPROPYLENE BACKREST

**ASSISE: TISSU AU CHOIX  
ASIENTO: TAPIZADO A ELEGIR  
UPHOLSTERED SEAT**

**Cf. page 508  
Ver pagina 508  
See page 508**



# FRILL

Au design universel italien, les chaises FRILL appartiennent à la famille Contract. Les points forts de cette série sont une grande variété de couleurs et de structures qui permettent de répondre à vos besoins les plus exigeants. Monocoque avec accoudoirs intégrés, FRILL est la soeur jumelle de NO-FRILL.

El diseño italiano es un referente universal. Esta serie forma parte de la familia Contract en la que la variedad de colores y estructuras es el punto fuerte para poder adaptarse al máximo a todas las opciones donde se requiera un mobiliario de estas características. FRILL es la melliza de NO-FRILL. Su monocarcasa plástica se caracteriza por tener los brazos integrados.

Italian design is a universal referral. This range belong to Contract chairs. A wide range of colors and frames are available to reach the most demanding expectation of the costumer. FRILL is NO-FRILL's sister. Its plastic shell has integrated arms.

Empilable  
Apilable  
Stackable



CHAISE GIRATOIRE  
SUR ROULETTES

GIRATORIA  
CON RUEDAS

SWIVEL CHAIR  
WITH WHEELS

Réglage en hauteur  
Regulación altura  
Height adjustment

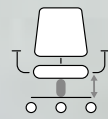

Assise avec placet rembourré.  
El asiento puede tapizarse.  
Upholstered seat available.

CHAISE  
PIÈTEMENT  
TRAÎNEAU

SILLA CON  
ESTRUCTURA  
PATÍN

SLED FRAME  
CHAIR



Les finitions des structures 4 pieds et traîneau peuvent être blanches, graphites ou chromées.  
La estructura de 4 patas o patín puede ser en acabado blanco, grafito o cromado.  
4 legs or sled frame can be in white, graphite or chrome finish.

CHAISE 4 PIEDS

SILLA CON 4 PATAS

4 LEGS CHAIR



Empilable jusqu'à 6 unités.  
Apilable hasta 6 unidades.  
Stackable up to 6 chairs.

CHAISE GIRATOIRE  
AVEC BASE  
PYRAMIDALE  
SUR PATINS

GIRATORIA  
PIRAMIDAL  
CON TOPES

PYRAMIDAL  
SWIVEL CHAIR  
WITH GLIDES



Bases pyramidales ou plates en aluminium poli. Chaise pivotante à 360° avec un système de retour automatique.  
Tanto la base plana como la piramidal son de aluminio pulido con sistema autoretorno y rotación de 360°.  
Polished aluminium swivel bases have 360° self-rotation system.

Monocoque avec accoudoirs intégrés.  
Tiene los brazos incluidos en la monocarcasa.  
Arms are integrated with the shell.





CHAISE GIRATOIRE  
AVEC BASE PLATE  
SUR PATINS



GIRATORIA  
PLANA CON  
TOPES

4-STAR SWIVEL  
CHAIR WITH  
GLIDES



## MODÈLES | VARIANTES | VERSIONS

MODÈLE / VARIANTES / VERSIONS	TYPE / TIPO / TYPE	RÉFÉRENCE / REFERENCIA / CODE		
 C	Assise et dossier: en polypropylène Asiento y respaldo: en polipropileno Polypropylene seat and backrest			
		159.272.-.-	159.372.-.-	159.472.-.-
 E	Assise: Tissu au choix. Dossier: en polypropylène Asiento: Tapizado a elegir. Respaldo: en polipropileno Upholstered seat. Polypropylene backrest			
		159.272.-.-	159.372.-.-	159.472.-.-





Chaise 4 pieds  
Silla de 4 patas  
4 legs

 C	Assise et dossier: en polypropylène Asiento y respaldo: en polipropileno Polypropylene seat and backrest	159.292.-.-	159.392.-.-	159.492.-.-
 E	Assise: Tissu au choix. Dossier: en polypropylène Asiento: Tapizado a elegir. Respaldo: en polipropileno Upholstered seat. Polypropylene backrest	159.292.-.-	159.392.-.-	159.492.-.-

Chaise avec pieds traîneau  
Sillas patin  
Sled frame

MODÈLE / VARIANTES / VERSIONS	TYPE / TIPO / TYPE	RÉFÉRENCE / REFERENCIA / CODE
 C	Assise et dossier: en polypropylène Asiento y respaldo: en polipropileno Polypropylene seat and backrest	
		159.512.-.-
 E	Assise: Tissu au choix. Dossier: en polypropylène Asiento: Tapizado a elegir. Respaldo: en polipropileno Upholstered seat. Polypropylene backrest	
		159.512.-.-

Giratoire sur roulettes  
Giratoria con ruedas  
Swivel base with wheels

MODÈLE / VARIANTES / VERSIONS	TYPE / TIPO / TYPE	RÉFÉRENCE / REFERENCIA / CODE
 C	Assise et dossier: en polypropylène Asiento y respaldo: en polipropileno Polypropylene seat and backrest	Pyramidale / Piramidal / Pyramidal 159.522.-.-
 C		Plate / Plana / 4 Stars 159.502.-.-
 E	Assise: Tissu au choix. Dossier: en polypropylène Asiento: Tapizado a elegir. Respaldo: en polipropileno Upholstered seat. Polypropylene backrest	159.522.-.-
 E		159.502.-.-

Chaise giratoire sur patins  
Silla giratoria con conteras  
Swivel base with glides

## FINITIONS | ACABADOS | FINISHES

### STRUCTURE ESTRUCTURA FRAME

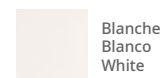

Blanche  
Blanco  
White



Graphite  
Grafito  
Graphite



Chromée  
Cromado  
Chrome

### TYPE TIPO TYPE

C ASSISE ET DOSSIER: POLYPROPYLÈNE  
ASIENTO Y RESPALDO: POLIPROPILENO  
POLYPROPYLENE SEAT AND BACKREST

341	Bleu clair Azul claro Light blue	281	Graphite Grafito Graphite	271	Blanc Blanco White	201	Orange Naranja Orange
291	Bleu foncé Azul oscuro Dark blue	241	Marron Marrón Beige	211	Jaune Amarillo Yellow		

### TYPE TIPO TYPE

E DOSSIER EN POLYPROPYLÈNE  
RESPALDO EN POLIPROPILENO  
POLYPROPYLENE BACKREST

541	Bleu clair Azul claro Light blue	881	Graphite Grafito Graphite	871	Blanc Blanco White	801	Orange Naranja Orange
891	Bleu foncé Azul oscuro Dark blue	841	Marron Marrón Beige	811	Jaune Amarillo Yellow		

ASSISE: TISSU AU CHOIX  
ASIENTO: TAPIZADO A ELEGIR  
UPHOLSTERED SEAT



Cf. page 508  
Ver pagina 508  
See page 508

## FINITIONS | ACABADOS | FINISHES

### BASE BASE BASE



Aluminium poli  
Aluminio pulido  
Polished aluminium

### TYPE TIPO TYPE

C ASSISE ET DOSSIER: POLYPROPYLÈNE  
ASIENTO Y RESPALDO: POLIPROPILENO  
POLYPROPYLENE SEAT AND BACKREST

341	Bleu clair Azul claro Light blue	281	Graphite Grafito Graphite	271	Blanc Blanco White	201	Orange Naranja Orange
291	Bleu foncé Azul oscuro Dark blue	241	Marron Marrón Beige	211	Jaune Amarillo Yellow		

### TYPE TIPO TYPE

E DOSSIER EN POLYPROPYLÈNE  
RESPALDO EN POLIPROPILENO  
POLYPROPYLENE BACKREST

541	Bleu clair Azul claro Light blue	881	Graphite Grafito Graphite	871	Blanc Blanco White	801	Orange Naranja Orange
891	Bleu foncé Azul oscuro Dark blue	841	Marron Marrón Beige	811	Jaune Amarillo Yellow		

ASSISE: TISSU AU CHOIX  
ASIENTO: TAPIZADO A ELEGIR  
UPHOLSTERED SEAT



Cf. page 508  
Ver pagina 508  
See page 508

# NO-FRILL

Au design universel italien, les chaises NO-FRILL appartiennent à la famille Contract. Les points forts de cette série sont une grande variété de couleurs et de structures qui permettent de répondre à vos besoins les plus exigeants.

Monocoque sans accoudoirs.

NO-FRILL est la soeur jumelle de FRILL.

El diseño italiano es un referente universal.

Esta serie forma parte de la familia Contract en la que la variedad de colores y estructuras es el punto fuerte para poder adaptarse al máximo a todas las opciones donde se requiera un mobiliario de estas características.

Su monocarcasa plástica no tiene brazos.

Italian design is a universal referral. This range belong to Contract chairs. A wide range of colors and frames are available to reach the most demanding expectation of the costumer.

Its plastic shell doesn't have arms.

Empilable  
Apilable  
Stackable



CHAISE  
PIÈTEMENT  
TRAÎNEAU

SILLA CON  
ESTRUCTURA  
PATÍN

SLED FRAME  
CHAIR



Empilable jusqu'à 6 unités.  
Apilable hasta 6 unidades.  
Stackable up to 6 chairs.

CHAISE GIRATOIRE  
AVEC BASE PLATE  
SUR PATINS

GIRATORIA  
PLANA CON  
TOPES

4-STAR SWIVEL  
CHAIR WITH  
GLIDES



Bases pyramidales ou plates en aluminium poli.  
Chaise pivotante à 360° avec un système de retour  
automatique.  
Tanto la base plana como la piramidal son de  
aluminio pulido con sistema autoretorno y  
rotación de 360°.  
Polished aluminium swivel bases have 360°  
self-rotation system.



Réglage en hauteur  
Regulación altura  
Height adjustment

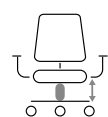

CHAISE GIRATOIRE  
SUR ROULETTES

GIRATORIA  
CON RUEDAS

SWIVEL CHAIR  
WITH WHEELS



Assise avec placet rembourré.  
El asiento puede tapizarse.  
Upholstered seat available.

CHAISE GIRATOIRE  
AVEC BASE  
PYRAMIDALE  
SUR PATINS

GIRATORIA  
PIRAMIDAL  
CON TOPES

PYRAMIDAL  
SWIVEL CHAIR  
WITH GLIDES





| CHAISE 4 PIEDS    | SILLA CON 4 PATAS    | 4 LEGS CHAIR





Les accoudoirs sont intégrés à la structure.  
No tiene los brazos incluidos en la monocarcasa pero si que puede tenerlos integrados en la estructura.  
The shell has no arms but frame can has integrated metal fixed arms.



Empilable  
Apilable  
Stackable



## MODÈLES | VARIANTES | VERSIONS

MODÈLE / VARIANTES / VERSIONS	TYPE / TIPO / TYPE	RÉFÉRENCE / REFERENCIA / CODE
 C	Assise et dossier: en polypropylène Asiento y respaldo: en polipropileno Polypropylene seat and backrest	Sans accoudoirs / Sin brazos / Without arms 160.271... 160.371... 160.471... Accoudoirs fixes / Con brazos / Fixed arms 160.272... 160.372... 160.472...
 E	Assise: Tissu au choix. Dossier: en polypropylène Asiento: Tapizado a elegir. Respaldo: en polipropileno Upholstered seat. Polypropylene backrest	Sans accoudoirs / Sin brazos / Without arms 160.271... 160.371... 160.471... Accoudoirs fixes / Con brazos / Fixed arms 160.272... 160.372... 160.472...

Chaise 4 pieds  
Silla de 4 patas  
4 legs

 C	Assise et dossier: en polypropylène Asiento y respaldo: en polipropileno Polypropylene seat and backrest	160.291... 160.391... 160.491...
 E	Assise: Tissu au choix. Dossier: en polypropylène Asiento: Tapizado a elegir. Respaldo: en polipropileno Upholstered seat. Polypropylene backrest	160.291... 160.391... 160.491...

Chaise avec pieds traîneau  
Sillas patin  
Sled frame

## FINITIONS | ACABADOS | FINISHES

### STRUCTURE ESTRUCTURA FRAME

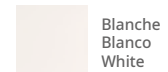

Blanche  
White



Graphite  
Grafito  
Graphite



Chromée  
Cromado  
Chrome

### TYPE TIPO TYPE

ASSISE ET DOSSIER: POLYPROPYLÈNE  
ASIENTO Y RESPALDO: POLIPROPILENO  
POLYPROPYLENE SEAT AND BACKREST

341	Bleu clair Azul claro Light blue	281	Graphite Grafito Graphite	271	Blanc Blanco White	201	Orange Naranja Orange
291	Bleu foncé Azul oscuro Dark blue	241	Marron Marrón Beige	211	Jaune Amarillo Yellow		

### TYPE TIPO TYPE



DOSSIER EN POLYPROPYLÈNE  
RESPALDO EN POLIPROPILENO  
POLYPROPYLENE BACKREST

541	Bleu clair Azul claro Light blue	881	Graphite Grafito Graphite	871	Blanc Blanco White	801	Orange Naranja Orange
891	Bleu foncé Azul oscuro Dark blue	841	Marron Marrón Beige	811	Jaune Amarillo Yellow		



ASSISE: TISSU AU CHOIX  
ASIENTO: TAPIZADO A ELEGIR  
UPHOLSTERED SEAT



Cf. page 508  
Ver pagina 508  
See page 508

MODÈLE / VARIANTES / VERSIONS	TYPE / TIPO / TYPE	RÉFÉRENCE / REFERENCIA / CODE
 C	Assise et dossier: en polypropylène Asiento y respaldo: en polipropileno Polypropylene seat and backrest	160.511...
 E	Assise: Tissu au choix. Dossier: en polypropylène Asiento: Tapizado a elegir. Respaldo: en polipropileno Upholstered seat. Polypropylene backrest	160.511...

Giratoire sur roulettes  
Giratoria con ruedas  
Swivel base with wheels

 C	Assise et dossier: en polypropylène Asiento y respaldo: en polipropileno Polypropylene seat and backrest	Pyramidale / Piramidal / Pyramidal 160.521...	Plate / Plana / 4 Stars 160.501...
 E	Assise: Tissu au choix. Dossier: en polypropylène Asiento: Tapizado a elegir. Respaldo: en polipropileno Upholstered seat. Polypropylene backrest	160.521...	160.501...

Chaise giratoire sur patins  
Silla giratoria con conteras  
Swivel base with glides

## FINITIONS | ACABADOS | FINISHES

### BASE BASE BASE



Aluminium poli  
Aluminio pulido  
Polished aluminium

### TYPE TIPO TYPE

ASSISE ET DOSSIER: POLYPROPYLÈNE  
ASIENTO Y RESPALDO: POLIPROPILENO  
POLYPROPYLENE SEAT AND BACKREST

341	Bleu clair Azul claro Light blue	281	Graphite Grafito Graphite	271	Blanc Blanco White	201	Orange Naranja Orange
291	Bleu foncé Azul oscuro Dark blue	241	Marron Marrón Beige	211	Jaune Amarillo Yellow		

### TYPE TIPO TYPE

DOSSIER EN POLYPROPYLÈNE  
RESPALDO EN POLIPROPILENO  
POLYPROPYLENE BACKREST

541	Bleu clair Azul claro Light blue	881	Graphite Grafito Graphite	871	Blanc Blanco White	801	Orange Naranja Orange
891	Bleu foncé Azul oscuro Dark blue	841	Marron Marrón Beige	811	Jaune Amarillo Yellow		

ASSISE: TISSU AU CHOIX  
ASIENTO: TAPIZADO A ELEGIR  
UPHOLSTERED SEAT



Cf. page 508  
Ver pagina 508  
See page 508

# Nut

Suivant les tendances nordiques les plus actuelles, la chaise NUT se compose d'une assise monocoque et d'une structure 4 pieds en bois naturel. Cette série se complète avec des tabourets de même esprit.

Siguiendo de cerca la tendencia escandinava más actual, NUT está compuesta por una carcasa de plástico y patas de madera. La serie también cuenta con un taburete.

Following nordic trends, NUT chair has a plastic shell with wood legs. It can also match with the stool of the same range.

CHAISE 4  
PIEDS EN BOIS

SILLA DE  
4 PATAS

4 LEGS  
CHAIR



## MODÈLES | VARIANTES | VERSIONS

MODÈLE / VARIANTES / VERSIONS	TYPE / TIPO / TYPE	RÉFÉRENCE / REFERENCIA / CODE
	4 U. / 4 U. / 4 chairs Assise et dossier en polypropylène Asiento y respaldo en polipropileno Polypropylene seat and backrest	155.671-...

Chaise 4 pieds en bois  
Silla de 4 patas  
4 wood legs

## FINITIONS | ACABADOS | FINISHES

STRUCTURE  
ESTRUCTURA  
FRAME

 Bois naturel  
Madera natural  
Natural wood

ASSISE ET DOSSIER: POLYPROPYLÈNE  
ASIENTO Y RESPALDO: POLIPROPILENO  
POLYPROPYLENE SEAT AND BACKREST

 214  
Noir  
Negro  
Black

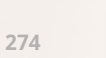
 274  
Blanc  
Blanco  
White

 264  
Gris  
Gris  
Grey

 224  
Bleu  
Azul  
Blue



# Hole

Chaise de lignes nordiques avec un design unique où les formes arrondies de l'assise sont les protagonistes.

Sillón de estilo nórdico con un diseño particular donde resaltan las líneas del respaldo.

Nordic style seating with sinuous shapes for seat and backrest.

CHAISE REMBOURRÉ  
AVEC PIÈTEMENT  
TRAÎNEAU

SILLA TAPIZADA  
CON PATÍN

UPHOLSTERED  
SLED CHAIR



CHAISE EN  
POLYPROPYLÈNE  
AVEC PIÈTEMENT  
TRAÎNEAU

SILLA DE  
POLIPROPILENO  
CON PATÍN

POLYPROPYLENE  
SLED CHAIR



Chaise originale sur structure traîneau chromée.  
Un modelo de silla muy peculiar con estructura  
patín cromada.  
An original chair with chrome sled frame.



## MODÈLES | VARIANTES | VERSIONS

MODÈLE / VARIANTES / VERSIONS	TYPE / TIPO / TYPE	RÉFÉRENCE / REFERENCIA / CODE
 A	Tissu Tapizado Upholstered	2 U. / 2 U. / 2 chairs 153.491... 4 U. / 4 U. / 4 chairs 153.491... 153.491... 153.491...
 C	Polypropylène Polipropileno Polypropylene	2 U. / 2 U. / 2 chairs 153.491... 4 U. / 4 U. / 4 chairs 153.491... 153.491... 153.491...

Chaise pieds traîneau  
Sillas patin  
Sled frame

## FINITIONS | ACABADOS | FINISHES

STRUCTURE  
ESTRUCTURA  
FRAME



TYPE  
TIPO  
TYPE

A

ASSISE ET DOSSIER EN TISSU  
ASIENTO Y RESPALDO TAPIZADOS  
UPHOLSTERED SEAT AND BACKREST

142

Noir  
Negro  
Black

152

Vert  
Verde  
Green

162

Bleu  
Azul  
Blue

172

Rose  
Rosa  
Pink

TYPE  
TIPO  
TYPE

C

ASSISE ET DOSSIER EN POLYPROPYLÈNE  
ASIENTO Y RESPALDO POLIPROPILENO  
POLYPROPYLENE SEAT AND BACKREST

214

Noir  
Negro  
Black

274

Blanc  
Blanco  
White

264

Gris  
Gris  
Grey

224

Bleu  
Azul  
Blue



# Hop

Chaise visiteur très tendance. La structure et la coque son fabriquées avec des matériaux de grande qualité.

Un diseño moderno y actual realizado con materiales de calidad tanto para la monocarcasa como para la estructura. Sorprende el acabado de sus detalles cuidados al máximo.

A trendy chair manufactured with good quality materials for shell and frame and with amazing details.





CHAISE 4  
PIEDS EN BOIS

SILLA DE  
4 PATAS

4 LEGS  
CHAIR



CHAISE AVEC  
PIÈTEMENT  
TRAÎNEAU

SILLA DE  
POLIPROPILENO  
CON PATÍN

POLYPROPYLENE  
SLED CHAIR



La structure peut être en 4 pieds en bois naturel ou en piètement traîneau chromé.

La estructura puede ser con 4 patas de madera o patín cromada.

Four wood legs or chrome sled frame.



## MODÈLES | VARIANTES | VERSIONS

MODÈLE / VARIANTES / VERSIONS	RÉFÉRENCE / REFERENCIA / CODE
 <p>Chaise pieds traîneau Sillas patin Sled frame</p>	<p>4 U. / 4 U. / 4 chairs</p> <p>154.492.---</p>
 <p>Chaise 4 pieds en bois Silla de 4 patas 4 wood legs</p>	<p>4 U. / 4 U. / 4 chairs</p> <p>154.672.---</p>

## FINITIONS | ACABADOS | FINISHES

### STRUCTURE ESTRUCTURA FRAME

Bois naturel  
Madera natural  
Natural wood



Chromée  
Cromado  
Chrome

### ASSISE ET DOSSIER: POLYPROPYLÈNE ASIENTO Y RESPALDO: POLIPROPILENO POLYPROPYLENE SEAT AND BACKREST

214 Noir Negro Black

274 Blanc Blanco White

264 Gris Gris Grey

224 Bleu Azul Blue



# Liner

Cette chaise aux formes contemporaines et aux très belles finitions, est parfaite pour l'équipement de salles d'attente, de halls, de bureaux ou de chambres d'hôtel.

Esta silla presenta muy buenos acabados y formas contemporaneas y atractivas, ideal para salas de espera, hoteles, habitaciones u oficinas.

This chair has good quality finishes and a contemporary and attractive shape. It's perfect for waiting areas, hotels, rooms or offices.

CHAISE 4  
PIEDS EN BOIS

SILLA DE  
4 PATAS  
DE MADERA

4 WOOD  
LEGS CHAIR



CHAISE 4 PIEDS  
MÉTALLIQUES

SILLA DE 4 PATAS  
METÁLICAS

4 METAL  
LEGS CHAIR



Structure 4 pieds disponible en bois naturel ou en métal.  
La estructura de la silla está disponible en 4 patas de madera o metálicas.  
Four metal or wood legs frame.



CHAISE 4  
PIEDS EN BOIS

SILLA DE  
4 PATAS  
DE MADERA

4 WOOD  
LEGS CHAIR

## MODÈLES | VARIANTES | VERSIONS

MODÈLE / VARIANTES / VERSIONS	TYPE / TIPO / TYPE	RÉFÉRENCE / REFERENCIA / CODE
 A	Tissu Tapizado Upholstered	2 U. / 2 U. / 2 chairs  156.672.-.-
 C	Polypropylène Polipropileno Polypropylene	4 U. / 4 U. / 4 chairs  156.672.-.-

Chaise 4 pieds en bois  
Silla de 4 patas  
4 wood legs



C

Polypropylène  
Polipropileno  
Polypropylene

4 U. / 4 U. / 4 chairs

156.472.-.-

Chaise 4 pieds  
Silla de 4 patas  
4 chrome legs

## FINITIONS | ACABADOS | FINISHES

STRUCTURE  
ESTRUCTURA  
FRAME



Chromée  
Cromado  
Chrome



Bois naturel  
Madera natural  
Natural wood

TYPE  
TIPO  
TYPE

A

ASSISE ET DOSSIER EN TISSU  
ASIENTO Y RESPALDO TAPIZADOS  
UPHOLSTERED SEAT AND BACKREST

142

Noir  
Negro  
Black

152

Vert  
Verde  
Green

162

Bleu  
Azul  
Blue

172

Rose  
Rosa  
Pink

TYPE  
TIPO  
TYPE

C

ASSISE ET DOSSIER EN POLYPROPYLÈNE  
ASIENTO Y RESPALDO POLIPROPILENO  
POLYPROPYLENE SEAT AND BACKREST

214

Noir  
Negro  
Black

274

Blanc  
Blanco  
White

264

Gris  
Gris  
Grey

224

Bleu  
Azul  
Blue



COLLECTIVITÉS  
AUXILIARES  
VISITOR



262 | TOM



272 | MARCO



282 | REPLAY



290 | HITO



296 | PLYS



302 | VIENA



310 | TEMA



316 | RED



322 | RODANO



330 | SPLIT



336 | NAVIA



344 | LARA

# Tom

Chaise aux lignes pures et minimalistes, la chaise TOM s'adapte à tous les espaces grâce à ces nombreuses versions.

Capaz de integrarse en cualquier espacio. La silla TOM se caracteriza por un estilo muy personal de líneas esbeltas y continuas, capaz de evolucionar en materiales, personalización y opciones.

Multipurpose chair with an elegant timeless style and shape.

Empilable  
Apilable  
Stackable





CHAISE  
4 PIEDS

SILLA CON  
4 PATAS

4 LEGS  
CHAIR

CHAISE SANS  
ACCOUDOIRS

SILLA 4 PATAS  
SIN BRAZOS

4 LEGS CHAIR  
WITHOUT ARMS

Coque en polypropylène disponible en noir,  
blanc, bleu, rouge ou gris.

Carcasa de polipropileno disponible en  
5 colores: negro, blanco, azul, rojo o gris.

Five shell colors available: black, white, blue, red  
or grey.



CHAISE AVEC  
ACCOUDOIRS

SILLA 4 PATAS  
CON BRAZOS

4 LEGS CHAIR  
WITH ARMS



CHAISE AVEC  
TABLETTE ÉCRITOIRE

SILLA CON PALA  
ESCRIBANÍA

CHAIR WITH  
WRITING TABLET



Tablette écrite pour gauchers ou pour droitiers.  
Escribanía para diestros o para zurdos.  
Right or left hand writing tablet.







La structure peut être en noir, argent ou chromé.

La estructura puede ser acabada en: negro, plata o cromado.



Available frame finishes: black, silver or chrome.



# MODÈLES | VARIANTES | VERSIONS

MODÈLE / VARIANTES / VERSIONS	TYPE / TIPO / TYPE	RÉFÉRENCE / REFERENCIA / CODE
 <p><b>B</b> Assise et dossier: Tissu. Asiento y respaldo: Tapizado. Upholstered seat and backrest</p>	Sans accoudoirs / Sin brazos / Without arms	 142.071.101  142.171.101  142.471.101
	Avec accoudoirs / Con brazos / With arms	142.072.101    142.172.101    142.472.101
 <p><b>C</b> Assise et dossier: en polypropylène Asiento y respaldo: en polipropileno Polypropylene seat and backrest</p>	Sans accoudoirs / Sin brazos / Without arms	142.071.-.-    142.171.-.-    142.471.-.-
	Avec accoudoirs / Con brazos / With arms	142.072.-.-    142.172.-.-    142.472.-.-
 <p><b>E</b> Assise: Tissu au choix. Dossier: en polypropylène Asiento: Tapizado a elegir. Respaldo: en polipropileno Upholstered seat. Polypropylene backrest</p>	Sans accoudoirs / Sin brazos / Without arms	142.071.-.-    142.171.-.-    142.471.-.-
	Avec accoudoirs / Con brazos / With arms	142.072.-.-    142.172.-.-    142.472.-.-

Chaise 4 pieds  
Silla de 4 patas  
4 legs













 <p><b>B</b> Assise et dossier: Tissu. Asiento y respaldo: Tapizado. Upholstered seat and backrest</p>	Tablette écrivain à droite / Escribanía derecha / Writing tablet right	142.075.101    142.175.101    142.475.101
	Tablette écrivain à gauche / Escribanía izquierda / Writing tablet left	142.076.101    142.176.101    142.476.101
 <p><b>C</b> Assise et dossier: en polypropylène Asiento y respaldo: en polipropileno Polypropylene seat and backrest</p>	Tablette écrivain à droite / Escribanía derecha / Writing tablet right	142.075.-.-    142.175.-.-    142.475.-.-
	Tablette écrivain à gauche / Escribanía izquierda / Writing tablet left	142.076.-.-    142.176.-.-    142.476.-.-
 <p><b>E</b> Assise: Tissu au choix. Dossier: en polypropylène Asiento: Tapizado a elegir. Respaldo: en polipropileno Upholstered seat. Polypropylene backrest</p>	Tablette écrivain à droite / Escribanía derecha / Writing tablet right	142.075.-.-    142.175.-.-    142.475.-.-
	Tablette écrivain à gauche / Escribanía izquierda / Writing tablet left	142.076.-.-    142.176.-.-    142.476.-.-

Visiteur 4 pieds, avec tablette écrivain (noire)  
Silla 4 patas con brazos y escribanía (negro)  
4 legs with writing tablet (black)

# FINITIONS | ACABADOS | FINISHES

## STRUCTURE ESTRUCTURA FRAME

-  Noire  
Negro  
Black  
RAL 9005
-  Argentée  
Plata  
Silver  
RAL 9006
-  Chromée  
Cromado  
Chrome

TYPE TIPO TYPE	<b>B</b>	ASSISE ET DOSSIER: TISSU AU CHOIX ASIENTO Y RESPALDO: TAPIZADO A ELEGIR UPHOLSTERED SEAT AND BACKREST	 Cf. page 508 Ver pagina 508 See page 508	 101 Tissu Tela Fabric
TYPE TIPO TYPE	<b>C</b>	POLYPROPYLÈNE POLIPROPILENO POLYPROPYLENE	 211 Noir Negro Black  271 Blanc Blanco White  221 Bleu Azul Blue  241 Rouge Rojo Red  261 Gris Gris Grey	
TYPE TIPO TYPE	<b>E</b>	DOSSIER: POLYPROPYLÈNE RESPALDO: POLIPROPILENO POLYPROPYLENE BACKREST	 Cf. page 508 Ver pagina 508 See page 508	 811 Noir Negro Black  871 Blanc Blanco White  821 Bleu Azul Blue   841 Rouge Rojo Red  861 Gris Gris Grey

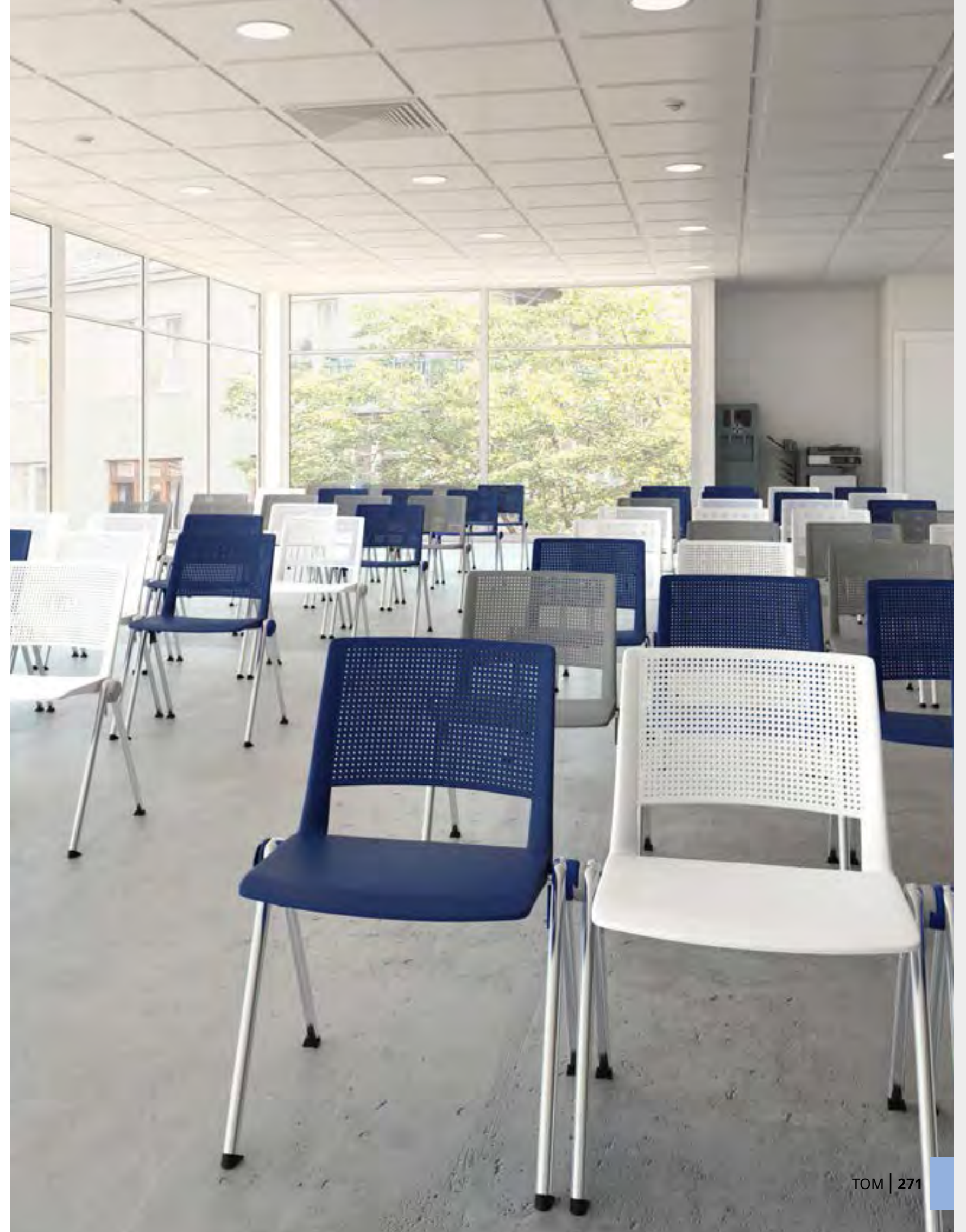

# Marco

Dans son segment, ce modèle est le numéro un des ventes. Proposée dans de nombreuses versions, cette famille de chaises est complétée par de nombreuses options vous permettant ainsi d'adapter cette chaise à chaque utilisation.

En su segmento, es el número uno de ventas y es el modelo que más versiones ofrece. Además tiene una serie de complementos para optimizar el uso de las sillas.

MARCO chair is a best seller seating product and has largest versions available. A range of accessories can also be chosen to optimise every-day use of the chair.

Empilable  
Apilable  
Stackable



CHAISE AVEC  
TABLETTE ÉCRITOIRE

SILLA CON PALA  
ESCRIBANÍA

CHAIR WITH  
WRITING TABLET



Tablette écrite rabattable renforcée, à droite ou à gauche en melamine.  
Escribanía derecha o izquierda y abatible en melamina.  
Folding right or left hand writing melamine tablet.



CHAISE VISITEUR 4  
PIEDS POLYPROPYLENE

SILLA 4 PATAS  
POLIPROPILENO

POLYPROPYLENE  
4 LEGS



Chaises facilement empilables.  
Se pueden apilar fácilmente.  
Easily stackable.

CHAISE AVEC  
ASSISE ET DOSSIER  
EN BOIS

ASIENTO Y  
RESPALDO EN  
MADERA

WOOD SEAT  
AND BACKREST



CHAISE VISITEUR  
4 PIEDS  
REMOURRÉ

SILLA 4 PATAS  
TAPIZADA

UPHOLSTERED  
4 LEGS



Mixte: dossier perforé en polypropylène  
noir et assise en tissu au choix.  
Mixta: respaldo negro perforado  
y asiento tapizado.  
Mixed: black drilled backrest and  
upholstered seat.



CHAISE VISITEUR  
4 PIEDS MIXTE

SILLA CON  
4 PATAS MIXTA

MIXED 4 LEGS  
CHAIR



## MODÈLES | VARIANTES | VERSIONS

MODÈLE / VARIANTES / VERSIONS	TYPE / TIPO / TYPE	RÉFÉRENCE / REFERENCIA / CODE
	Sans accoudoirs / Sin brazos / Without arms Avec accoudoirs / Con brazos / With arms	87.711.-.- 87.261.001
	Sans accoudoirs / Sin brazos / Without arms	87.711.-.-

Visiteur 4 pieds  
Confidente 4 patas  
4 Legs

MODÈLE / VARIANTES / VERSIONS	TYPE / TIPO / TYPE	RÉFÉRENCE / REFERENCIA / CODE
	À droite / Derecha / Right hand	87.716.-.-

Visiteur 4 pieds avec tablette écritoire en polypropylène noir  
Confidente 4 patas con escribanía en polipropileno negro  
4 legs chairs with black polypropylene writing tablet

## FINITIONS | ACABADOS | FINISHES

### STRUCTURE ESTRUCTURA FRAME

	Noir Negro Black RAL 9005
	Argentée Plata Silver RAL 9006
	Graphite Grafito Graphite RAL 7022

### B ASSISE ET DOSSIER: TISSU AU CHOIX ASIENTO Y RESPALDO: TAPIZADO A ELEGIR UPHOLSTERED SEAT AND BACKREST

	101 Tissu Tela Fabric
	105 Tissu Tela Fabric
	107 Tissu Tela Fabric

Cf. page 508  
Ver pagina 508  
See page 508

### C ASSISE ET DOSSIER EN POLYPROPYLÈNE ASIENTO Y RESPALDO EN POLIPROPILENO POLYPROPYLENE SEAT AND BACKREST

	211 Noir Negro Black		221 Bleu Azul Blue		231 Vert Vedre Green		241 Rouge Rojo Red		251 Jaune Amarillo Yellow
	215 Noir Negro Black		225 Bleu Azul Blue		235 Vert Vedre Green		245 Rouge Rojo Red		255 Jaune Amarillo Yellow
	217 Noir Negro Black		227 Bleu Azul Blue		237 Vert Vedre Green		247 Rouge Rojo Red		257 Jaune Amarillo Yellow

### STRUCTURE ESTRUCTURA FRAME

	Noir Negro Black RAL 9005
	Argentée Plata Silver RAL 9006
	Graphite Grafito Graphite RAL 7022

### E ASSISE: TISSU AU CHOIX + DOSSIER EN POLYPROPYLÈNE ASIENTO: TAPIZADO A ELEGIR + RESPALDO POLIPROPILENO UPHOLSTERED SEAT + POLYPROPYLENE BACKREST

	301 Tissu Tela Fabric
	305 Tissu Tela Fabric
	307 Tissu Tela Fabric

Cf. page 508  
Ver pagina 508  
See page 508

### I ASSISE ET DOSSIER CONTRE-PLAQUÉ ASIENTO Y RESPALDO: MADERA LAMINADA WOOD SEAT AND BACKREST

	411 Hêtre Naturel Haya natural Natural beech		421 Poirier Peral Pear		431 Vert Vedre Green		441 Bleu Azul Blue
	415 Hêtre Naturel Haya natural Natural beech		425 Poirier Peral Pear		435 Vert Vedre Green		445 Bleu Azul Blue
	417 Hêtre Naturel Haya natural Natural beech		427 Poirier Peral Pear		437 Vert Vedre Green		447 Bleu Azul Blue

## MODÈLES | VARIANTES | VERSIONS

MODÈLE / VARIANTES / VERSIONS	TYPE / TIPO / TYPE	RÉFÉRENCE / REFERENCIA / CODE
	À droite / Derecha / Right hand	87.712.-.-
	À gauche / Izquierda / Left hand	87.713.-.-

Visiteur 4 pieds avec tablette écritoire en melamine  
Confidente 4 patas con escribanía en melamina  
4 legs with melamine writing tablet

## FINITIONS | ACABADOS | FINISHES

### STRUCTURE ESTRUCTURA FRAME

	Noir Negro Black RAL 9005
	Argentée Plata Silver RAL 9006
	Graphite Grafito Graphite RAL 7022

### Tablette écritoire Escribanía Writing tablet

	Melamine Melamina Melamine
--	----------------------------------

### B ASSISE ET DOSSIER: TISSU AU CHOIX ASIENTO Y RESPALDO: TAPIZADO A ELEGIR UPHOLSTERED SEAT AND BACKREST

	101 Tissu Tela Fabric
	102 Tissu Tela Fabric
	105 Tissu Tela Fabric
	106 Tissu Tela Fabric
	107 Tissu Tela Fabric
	108 Tissu Tela Fabric

Cf. page 508  
Ver pagina 508  
See page 508

### C ASSISE ET DOSSIER EN POLYPROPYLÈNE ASIENTO Y RESPALDO EN POLIPROPILENO POLYPROPYLENE SEAT AND BACKREST

	211 Noir Negro Black		221 Bleu Azul Blue		231 Vert Vedre Green		241 Rouge Rojo Red		251 Jaune Amarillo Yellow
	212 Noir Negro Black		222 Bleu Azul Blue		232 Vert Vedre Green		242 Rouge Rojo Red		252 Jaune Amarillo Yellow
	215 Noir Negro Black		225 Bleu Azul Blue		235 Vert Vedre Green		245 Rouge Rojo Red		255 Jaune Amarillo Yellow
	216 Noir Negro Black		226 Bleu Azul Blue		236 Vert Vedre Green		246 Rouge Rojo Red		256 Jaune Amarillo Yellow
	217 Noir Negro Black		227 Bleu Azul Blue		237 Vert Vedre Green		247 Rouge Rojo Red		257 Jaune Amarillo Yellow
	218 Noir Negro Black		228 Bleu Azul Blue		238 Vert Vedre Green		248 Rouge Rojo Red		258 Jaune Amarillo Yellow

### STRUCTURE ESTRUCTURA FRAME

	Noir Negro Black RAL 9005
	Argentée Plata Silver RAL 9006
	Graphite Grafito Graphite RAL 7022

### Tablette écritoire Escribanía Writing tablet

	Melamine Melamina Melamine
--	----------------------------------

### E ASSISE: TISSU AU CHOIX + DOSSIER EN POLYPROPYLÈNE ASIENTO: TAPIZADO A ELEGIR + RESPALDO POLIPROPILENO UPHOLSTERED SEAT + POLYPROPYLENE BACKREST

	301 Tissu Tela Fabric
	302 Tissu Tela Fabric
	305 Tissu Tela Fabric
	306 Tissu Tela Fabric
	307 Tissu Tela Fabric
	308 Tissu Tela Fabric

Cf. page 508  
Ver pagina 508  
See page 508

### I ASSISE ET DOSSIER CONTRE-PLAQUÉ ASIENTO Y RESPALDO: MADERA LAMINADA WOOD SEAT AND BACKREST

	411 Hêtre Naturel Haya natural Natural beech		421 Poirier Peral Pear		431 Vert Vedre Green		441 Bleu Azul Blue
	412 Hêtre Naturel Haya natural Natural beech		422 Poirier Peral Pear		432 Vert Vedre Green		442 Bleu Azul Blue
	415 Hêtre Naturel Haya natural Natural beech		425 Poirier Peral Pear		435 Vert Vedre Green		445 Bleu Azul Blue
	416 Hêtre Naturel Haya natural Natural beech		426 Poirier Peral Pear		436 Vert Vedre Green		446 Bleu Azul Blue
	417 Hêtre Naturel Haya natural Natural beech		427 Poirier Peral Pear		437 Vert Vedre Green		447 Bleu Azul Blue
	418 Hêtre Naturel Haya natural Natural beech		428 Poirier Peral Pear		438 Vert Vedre Green		448 Bleu Azul Blue

## MODÈLES | VARIANTES | VERSIONS

MODÈLE / VARIANTES / VERSIONS	TYPE / TIPO / TYPE	RÉFÉRENCE / REFERENCIA / CODE
	Sans accoudoirs / Sin brazos / Without arms	87.111.001
	Avec accoudoirs / Con brazos / With arms	87.211.001

Chaise giratoire  
Sillas giratoria  
Swivel chairs

Cf. page 508  
Ver pagina 508  
See page 508

# Replay

Simplicité et design. La chaise REPLAY est très polyvalente et s'adapte à tout type d'ambiance.

La silla REPLAY sigue una estética atemporal indiferente a estilos y a tendencias.

Replay chair has a timeless style and matches with any trend.

Empilable  
Apilable  
Stackable



CHAISE 4 PIEDS  
AVEC SYSTÈME  
D'UNION

SILLA CON 4 PATAS  
CON GANCHO DE  
UNIÓN

4 LEGS CHAIR  
WITH LINKING  
BRACKET

Possibilité d'avoir un système d'union pour unir les chaises entre elles.  
Con herraje de unión opcional para unir las sillas entre sí.  
With joining fitting to join chairs in a row.

CHAISE  
4 PIEDS AVEC  
ACCOUDOIRS

SILLA CON  
4 PATAS Y  
BRAZOS

4 LEGS CHAIR  
WITH ARMS

Disponible avec ou sans accoudoirs.  
Disponible con o sin brazos.  
Frame available with or without arms.



Coque en polypropylène avec le dossier micro perforé  
disponible en noir, blanc, bleu, rouge ou gris.  
Carcasa plástica con el respaldo perforado en distintos  
colores: negro, blanco, azul, rojo o gris.  
Plastic drilled backrest in different finishes: black, white,  
blue, red or grey.

CHAISE  
4 PIEDS

SILLA CON  
4 PATAS

4 LEGS  
CHAIR



La structure peut être noire, argentée ou chromée.  
Acabados de la estructura en negro, plata o cromado.  
Frame finishes: black, silver or chrome.

## MODÈLES | VARIANTES | VERSIONS

MODÈLE / VARIANTES / VERSIONS	TYPE / TIPO / TYPE	RÉFÉRENCE / REFERENCIA / CODE			
	Assise et dossier: en polypropylène Asiento y respaldo: en polipropileno Polypropylene seat and backrest	Sans accoudoirs / Sin brazos / Without arms Avec accoudoirs / Con brazos / With arms	143.071.-.- 143.072.-.-	143.171.-.- 143.172.-.-	143.471.-.- 143.472.-.-
Chaise 4 pieds Silla de 4 patas 4 legs					





	Assise et dossier: en polypropylène Asiento y respaldo: en polipropileno Polypropylene seat and backrest	Sans accoudoirs / Sin brazos / Without arms Avec accoudoirs / Con brazos / With arms	143.079.-.- 143.074.-.-	143.179.-.- 143.174.-.-	143.479.-.- 143.474.-.-
Chaise 4 pieds, avec système d'union Silla de 4 patas, con sistema de unión entre sillas 4 legs with linking bracket					

## FINITIONS | ACABADOS | FINISHES

### STRUCTURE ESTRUCTURA FRAME

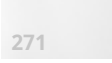
	Noire Negro Black RAL 9005
	Argentée Plata Silver RAL 9006
	Chromée Cromado Chrome

### ASSISE ET DOSSIER: POLYPROPYLÈNE ASIENTO Y RESPALDO: POLIPROPILENO POLYPROPYLENE SEAT AND BACKREST

	Noir Negro Black		Blanc Blanco White		Bleu Azul Blue
	Rouge Rojo Red		Gris Gris Grey		



# Hito

Chaise résistante et manéable pour les espaces communautaires. La coque caractéristique en différentes couleurs renforce sa présence partout où elle passe.

Carácter, durabilidad y todo terreno para espacios de colectividades. Su característica carcasa y su variedad de acabados realzan su presencia vaya donde vaya.

Character, flexibility and all-terrain for community spaces. Its characteristic seat-shell and its variety of finishes enhance its presence wherever it goes.



Empilable  
Apilable  
Stackable



CHAISE SANS  
ACCOUDOIRS

SILLA 4 PATAS  
SIN BRAZOS

4 LEGS CHAIR  
WITHOUT ARMS





Coque en polypropylène disponible en noir, bleu, vert ou anthracite.  
Carcasa de polipropileno disponible en 4 colores: negro, azul, verde o grafito  
Four shell colors available: black, blue, green or graphite



Empilable  
Apilable  
Stackable























# MODÈLES | VARIANTES | VERSIONS

MODÈLE / VARIANTES / VERSIONS	TYPE / TIPO / TYPE	RÉFÉRENCE / REFERENCIA / CODE			
	Sans accoudoirs / Sin brazos / Without arms				
Visiteur 4 pieds Confidente 4 patas 4 legs		66.711.---	66.711.---	66.711.---	66.711.---
	Sans accoudoirs / Sin brazos / Without arms	66.811.---	66.811.---	66.811.---	66.811.---
Chaise appui sur table - acier Balancín inverso - acero Inverted cantilever - steel					
	Sans accoudoirs / Sin brazos / Without arms	66.911.---	66.911.---	66.911.---	
Chaise appui sur table - aluminium Balancín inverso - aluminio Inverted cantilever - aluminium					
	Sans accoudoirs / Sin brazos / Without arms				
Giratoire Silla giratoria Conference chairs					66.111.---

# FINITIONS | ACABADOS | FINISHES

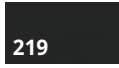
STRUCTURE  
ESTRUCTURA  
FRAME

ASSISE ET DOSSIER: POLYPROPYLÈNE  
ASIENTO Y RESPALDO: POLIPROPILENO  
POLYPROPYLENE SEAT AND BACKREST

 Noire Negro Black <small>RAL 9005</small>	 211 Noire Negro Black	 221 Bleu Azul Blue	 231 Vert Verde Green	 281 Graphite Grafito Graphite
 Argentée Plata Silver <small>RAL 9006</small>	 215 Noire Negro Black	 225 Bleu Azul Blue	 235 Vert Verde Green	 285 Graphite Grafito Graphite
 Graphite Grafito Graphite <small>RAL 7022</small>	 217 Noire Negro Black	 227 Bleu Azul Blue	 237 Vert Verde Green	 287 Graphite Grafito Graphite
 Chromée Cromado Chrome	 219 Noire Negro Black	 229 Bleu Azul Blue	 239 Vert Verde Green	 289 Graphite Grafito Graphite





# Plys

Plys est synonyme de praticité et de mobilité.  
Une chaise avec assise rabattable idéale pour  
les réunions informelles et pour formations.

Plys es sinónimo de practicidad y movilidad. Una  
silla plegable ideal para reuniones informales y  
formaciones.

Plys is synonymous with practicality and  
mobility. A folding chair ideal for informal  
meetings and training.

Assise rabattable  
Asiento abatible  
Foldable seat



VISITEUR 4  
PIEDS SUR  
ROULETTES

SILLA CON 4  
PATAS Y CON  
RUEDAS

4 LEGS  
CHAIR WITH  
CASTORS



Dossier en résille noire et structure blanche.  
Respaldo en rejilla negra y estructura blanca.  
Black backrest mesh and white frame.



## MODÈLES | VARIANTES | VERSIONS

MODÈLE / VARIANTES / VERSIONS	TYPE / TIPO / TYPE	RÉFÉRENCE / REFERENCIA / CODE
	Avec accoudoirs fixes / Con brazos fijos / With fixed arms	1 U. / 1 U. / 1 Item <span style="float: right;">170.102.321</span> 4 U. / 4 U. / 4 Items <span style="float: right;">170.102.325</span>
	Avec accoudoirs fixes / Con brazos fijos / With fixed arms	1 U. / 1 U. / 1 Item <span style="float: right;">170.102.322</span> 4 U. / 4 U. / 4 Items <span style="float: right;">170.102.326</span>

Visiteur 4 pieds avec roulettes  
4 patas con ruedas  
4 leg visitor chair with casters

## FINITIONS | ACABADOS | FINISHES

STRUCTURE  
ESTRUCTURA  
FRAME



Noire  
Negro  
Black



Blanche  
Blanco  
White

ASSISE  
ASIENTO  
SEAT



Noir  
Negro  
Black

DOSSIER  
RESPALDO  
BACKREST



Résille noire  
Rejilla negra  
Black mesh



# Vienna

Chaises à quatre pieds avec roulettes et assise rabattable, idéales pour les tables NET.

Les chaises VIENA sont parfaites pour les salles polyvalentes.

Silla con 4 patas y ruedas complementaria a la serie de mesas NET ideales para equipar salas con diferentes usos o distribuciones muy cambiantes.

Four legs chair with wheels that matches with NET desk range. These chairs are perfect for multipurpose rooms.



Assise rabattable  
Asiento abatible  
Foldable seat



Dossier réglable  
Inclinación respaldo  
Backrest adjustment

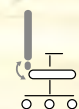

CHAISE VISITEUR  
4 PIEDS SUR  
ROULETTES

SILLA CON 4  
PATAS Y CON  
RUEDAS

4 LEGS  
CHAIR WITH  
CASTORS

Chaise confortable, légère et très fonctionnelle.

Una silla ligera, funcional y cómoda.

This chair is comfortable, light and very functional.

| CHAISE VISITEUR  
| LUGE

| SILLA BALANCÍN

| CANTILEVER CHAIR



Structure argentée, dossier en résille  
noire et assise en tissu noir.

Respaldo en rejilla negra, balancín  
acabado plata y asiento con tela  
transpirable negra.

Black mesh backrest, black breathable  
seat fabric and silver frame.



## MODÈLES | VARIANTES | VERSIONS

MODÈLE / VARIANTES / VERSIONS	TYPE / TIPO / TYPE	RÉFÉRENCE / REFERENCIA / CODE	
 <p>Visiteur 4 pieds avec roulettes 4 patas con ruedas 4 legs with wheels</p>	Avec accoudoirs fixes / Con brazos fijos / With fixed arms	1 U. / 1 U. / 1 chairs	4 U. / 4 U. / 4 chairs
		126.102.321	126.102.325
 <p>Luge Balancín Cantilever</p>	Avec accoudoirs fixes / Con brazos fijos / With fixed arms	1 U. / 1 U. / 1 chairs	3 U. / 3 U. / 3 chairs
		126.802.321	126.802.323

## FINITIONS | ACABADOS | FINISHES

STRUCTURE  
ESTRUCTURA  
FRAME



Argentée  
Plata  
Silver

ASSISE  
ASIENTO  
SEAT



Noire  
Negro  
Black

DOSSIER  
RESPALDO  
BACKREST



Résille noire  
Rejilla negra  
Black mesh



# Tema

Une chaise qui s'adapte à divers environnements de travail. Avec un dossier en polypropylène noir perforé et recouvert d'une maille noire.

Una única silla para dar respuesta a entornos de trabajo diversos. TEMA se configura con un respaldo perforado de polipropileno negro y cubierto por una red también en color negro.

A single chair to respond to diverse work environments. TEMA visitor chair is configured with a black polypropylene reinforced mesh backrest.

Empilable  
Apilable  
Stackable

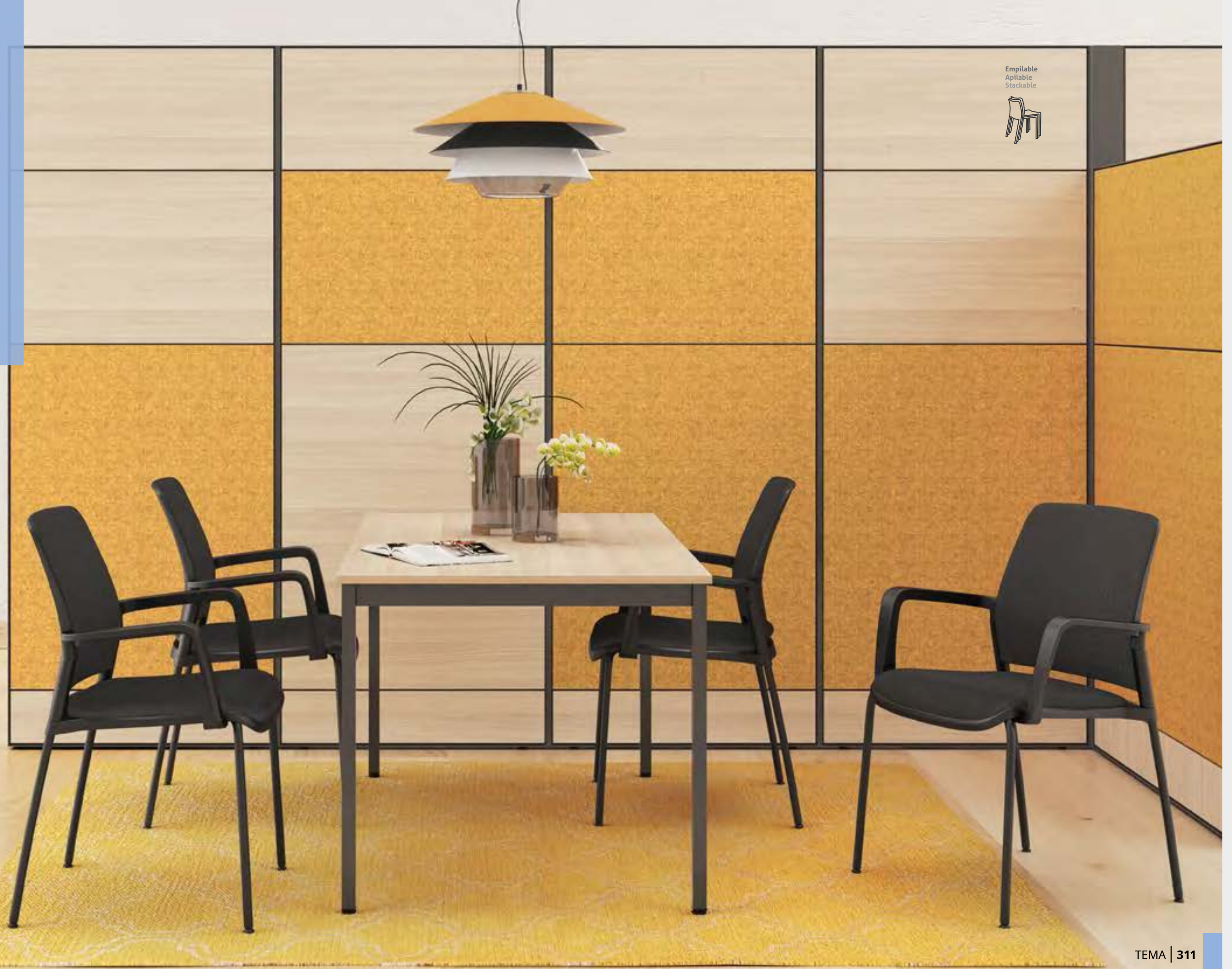



CHAISE 4 PIEDS  
AVEC ACCOUDOIRS

SILLA 4 PATAS  
CON BRAZOS

4 LEGS CHAIR  
WITH ARMS



Dossier en résille noire et assise rembourrée en tissu noir.  
Respaldo en rejilla negra y asiento tapizado negro.  
Black mesh backrest and black upholstered seat.



## MODÈLES | VARIANTES | VERSIONS

MODÈLE / VARIANTES / VERSIONS	TYPE / TIPO / TYPE	RÉFÉRENCE / REFERENCIA / CODE
 <p>Visiteur 4 pieds Confidente 4 patas 4 legs</p>	Avec accoudoirs / Con brazos / With arms	1 U. / 1 U. / 1 chair 166.712.322
		4 U. / 4 U. / 4 chairs 166.712.329

## FINITIONS | ACABADOS | FINISHES

STRUCTURE / ASSISE  
ESTRUCTURA / ASIENTO  
FRAME / SEAT

 Noir  
Negro  
Black  
RAL 9005

DOSSIER  
RESPALDO  
BACKREST

 Résille noire  
Rejilla negra  
Black mesh



# Red

Chaise élégante avec grandes prestations. La qualité de l'assise et sa finition chromée donnent à cette chaise une touche de sophistication.

Silla elegante y de grandes prestaciones. La calidad del asiento y de su acabado cromado le dan a esta silla un toque de sofisticación.

Elegant visitor chair and great performance. The quality of the seat and its chrome finish give this chair a touch of sophistication.



Empilable  
Apilable  
Stackable





Dossier en résille noire.  
Respaldo en rejilla negra.  
Black mesh backrest.

Accoudoirs fixes fabriqués en polypropylène noir.  
Brazos fijos fabricados con polipropileno negro.  
Fixed arms manufactured in black polypropylene.



Modèle empilable, maximum 5 sièges.  
Modo apilable en un máximo de 5 sillas.  
Stackable up to 5 chairs.



# MODÈLES | VARIANTES | VERSIONS

MODÈLE / VARIANTES / VERSIONS	TYPE / TIPO / TYPE	RÉFÉRENCE / REFERENCIA / CODE
 Chaise 4 pieds Silla de 4 patas 4 legs	Accoudoirs fixes / Brazos fijos / Fixed arms	1 U. / 1 U. / 1 chair
		5 U. / 5 U. / 5 chairs
		125.712.322
		125.712.329

# FINITIONS | ACABADOS | FINISHES

STRUCTURE  
ESTRUCTURA  
FRAME



Chromée  
Cromado  
Chrome

ASSISE  
ASIENTO  
SEAT



Noir  
Negro  
Black

DOSSIER  
RESPALDO  
BACKREST



Résille noire  
Rejilla negra  
Black mesh



# Ródano

Chaise avec une trajectoire très consolidée sur le marché. Elle vous offre un grand nombre de finitions de structure avec accoudoirs intégrés.

Il vous suffira de choisir le coloris de tissu adapté à l'environnement que vous souhaitez créer.

Esta silla tiene una trayectoria muy consolidada en el mercado y una amplia gama de acabados para la estructura. Se puede escoger cualquier tela o piel del catálogo de tapizados.

This chair has a very consolidated background in the furniture market and a wide range of finishes for its structure. Any finish of the fabric and leather folder is suitable.

Empilable  
Apilable  
Stackable



CHAISE VISITEUR  
4 PIEDS

SILLA CON 4  
PATAS

4 LEGS  
CHAIR

Structure avec accoudoirs intégrés disponible en coloris noir, argent, graphite ou chromé.  
Estructura disponible en negro, plata, grafito o cromada.  
Frame available finishes: black, silver, graphite or chrome.



CHAISE VISITEUR  
4 PIEDS

SILLA 4 PATAS

4 LEGS CHAIR

CHAISE AVEC  
TABLETTE  
ÉCRITOIRE

SILLA  
CON PALA  
ESCRIBANÍA

CHAIR WITH  
WRITING TABLET



Assise et dossier en tissu.  
Asiento y respaldó tapizados.  
Upholstered back and seat.







Tablette écrioire à droite en option.  
Con escribanía a la derecha opcional.  
Optional right writing tablet.





## MODÈLES | VARIANTES | VERSIONS

MODÈLE / VARIANTES / VERSIONS	RÉFÉRENCE / REFERENCIA / CODE			
				
	89.261.001	89.265.001	89.267.001	89.269.001

Visiteur 4 pieds  
Confidente 4 patas  
4 Legs

	89.251.001	89.255.001	89.257.001	89.259.001
---	------------	------------	------------	------------

Visiteur 4 pieds avec tablette écriroire en polypropylène noire  
Confidente 4 patas con escribanía en polipropileno negro  
4 legs chairs with black polypropylene writing tablet

## FINITIONS | ACABADOS | FINISHES

STRUCTURE  
ESTRUCTURA  
FRAME

 Noire  
Negro  
Black  
RAL 9005

 Argentée  
Plata  
Silver  
RAL 9006

 Graphite  
Grafito  
Graphite  
RAL 7022

 Chromée  
Cromado  
Chrome

ASSISE ET DOSSIER: TISSU AU CHOIX  
ASIENTO Y RESPALDO: TAPIZADO A ELEGIR  
UPHOLSTERED SEAT AND BACKREST

 Cf. page 508  
Ver pagina 508  
See page 508



# Split

L'élégance de son design et le détail de ses finitions constituent une gamme de sièges qui vous donnera pleine satisfaction pendant de nombreuses années.

La elegancia de sus líneas y el detalle de los acabados constituyen un modelo que dará plena satisfacción durante muchos años.

Chair with an elegant design and high-quality finishes that guarantees user comfort for a long period of time.

CHAISE VISITEUR  
4 PIEDS

SILLA CON 4  
PATAS

4 LEGS  
CHAIR



Empilable  
Apilable  
Stackable



CHAISE VISITEUR  
AVEC ACCOUDOIRS

SILLA CON  
BRAZOS





CHAIR WITH  
ARMS



La structure peut être en noir, argent, graphite ou chromé.  
La estructura puede ser en acabado negro, plata, grafito o cromado.  
Available finishes for the frame are: black, silver, graphite or chrome.



## MODÈLES | VARIANTES | VERSIONS

MODÈLE / VARIANTES / VERSIONS	RÉFÉRENCE / REFERENCIA / CODE			
				
	98.712.101	98.712.105	98.712.107	98.712.109

Visiteur 4 pieds  
Confidente 4 patas  
4 Legs

## FINITIONS | ACABADOS | FINISHES

STRUCTURE  
ESTRUCTURA  
FRAME

  
Noire  
Negro  
Black  
RAL 9005

  
Argentée  
Plata  
Silver  
RAL 9006

  
Graphite  
Grafito  
Graphite  
RAL 7022

  
Chromée  
Cromado  
Chrome

ASSISE ET DOSSIER: TISSU AU CHOIX  
ASIENTO Y RESPALDO: TAPIZADO A ELEGIR  
UPHOLSTERED SEAT AND BACKREST

  
Cf. page 508  
Ver pagina 508  
See page 508



# Navia

NAVIA est une série de chaises polyvalentes, fabriquée en bois, au design moderne disponible en deux versions. Cette chaise est déclinée soit avec une structure à quatre pieds, soit avec une structure prévue pour un appui sur table, en acier ou en aluminium, recommandée pour les locaux qui ont besoin d'un nettoyage quotidien.

El encanto de la madera presentada en colores contribuye a la gran versatilidad de esta silla. Este modelo está en versión cuatro patas o balancín inverso. En los locales que requieren una manipulación diaria, por motivos de limpieza, se aconseja que se elija el modelo con armazón de aluminio.

NAVIA is a versatile product range with charming wood finishes. The product is available in two versions: Four legs frame or inverted cantilever frame. Aluminium frame version is highly recommended in case is used in rooms where is done daily maintenance or cleaning.



Empilable  
Apilable  
Stackable



CHAISE VISITEUR  
4 PIEDS

SILLA CON 4  
PATAS

4 LEGS  
CHAIR



Finitions disponibles de la coque en bois:  
hêtre naturel, poirier, vert ou bleu.  
Los acabados de madera son: haya  
natural, peral, verde o azul.  
Wood finishes are: natural beech, pear,  
green or blue.

CHAISE VISITEUR  
4 PIEDS

SILLA CON 4  
PATAS

4 LEGS  
CHAIR

La structure peut être noire, argentée,  
graphite ou chromée.  
Estructura disponible en negro, plata,  
grafito o cromado.  
Available frame finishes: black, silver,  
graphite or chrome.



Dossier avec un design exclusif.  
Respaldo con un diseño exclusivo.  
Exclusive backrest design.



CHAISE APPUI  
SUR TABLE

SILLA CON  
BALANCÍN  
INVERSO

INVERSE  
CANTILEVER CHAIR





















## MODÈLES | VARIANTES | VERSIONS

MODÈLE / VARIANTES / VERSIONS	RÉFÉRENCE / REFERENCIA / CODE
 Visiteur 4 pieds Confidente 4 patas 4 Legs	 88.711.-.-      88.711.-.-

## FINITIONS | ACABADOS | FINISHES

STRUCTURE  
ARMAZÓN  
FRAME

ASSISE ET DOSSIER: CONTRE-PLAQUÉ  
ASIENTO Y RESPALDO: MADERA LAMINADA  
WOOD SEAT AND BACKREST

 Noire Negro Black <small>RAL 9005</small>	 411 Hêtre Naturel Haya natural Natural beech	 421 Poirier Peral Pear	 431 Vert Verde Green	 441 Bleu Azul Blue
 Argentée Plata Silver <small>RAL 9006</small>	 415 Hêtre Naturel Haya natural Natural beech	 425 Poirier Peral Pear	 435 Vert Verde Green	 445 Bleu Azul Blue
 Graphite Grafito Graphite <small>RAL 7022</small>	 417 Hêtre Naturel Haya natural Natural beech	 427 Poirier Peral Pear	 437 Vert Verde Green	 447 Bleu Azul Blue
 Chromée Cromado Chrome	 419 Hêtre Naturel Haya natural Natural beech	 429 Poirier Peral Pear	 439 Vert Verde Green	 449 Bleu Azul Blue









## MODÈLES | VARIANTES | VERSIONS

 Chaise appui sur table Balancín inverso Inverted cantilever	 Acier / Acero / Steel 88.811.-.-      88.811.-.-
--	---

## FINITIONS | ACABADOS | FINISHES

STRUCTURE  
ARMAZÓN  
FRAME

ASSISE ET DOSSIER: CONTRE-PLAQUÉ  
ASIENTO Y RESPALDO: MADERA LAMINADA  
WOOD SEAT AND BACKREST

 Noire Negro Black <small>RAL 9005</small>	 411 Hêtre Naturel Haya natural Natural beech
 Argentée Plata Silver <small>RAL 9006</small>	 415 Hêtre Naturel Haya natural Natural beech
 Graphite Grafito Graphite <small>RAL 7022</small>	 417 Hêtre Naturel Haya natural Natural beech
 Chromée Cromado Chrome	 419 Hêtre Naturel Haya natural Natural beech





# Lara

Chaise pliante. Son chariot de transport, avec une capacité allant jusqu'à 72 unités, facilitera le stockage et les déplacements.

Silla plegable, le recomendamos el carro de transporte con capacidad para hasta 72 unidades que facilitará el almacenamiento y los traslados de sus sillas.

If a large number of these foldable chairs are required, a storage trolley of 72 unit capacity is recommended for storage and transportation.



Empilable  
Apilable  
Stackable



CHAISE VISITEUR 4  
PIEDS POLYPROPYLENE

SILLA 4 PATAS  
POLIPROPILENO

POLYPROPYLENE  
4 LEGS



Empilable.  
Apilable.  
Stackable.



## MODÈLES | VARIANTES | VERSIONS

MODÈLE / VARIANTES / VERSIONS	TYPE / TIPO / TYPE	RÉFÉRENCE / REFERENCIA / CODE
	Sans accoudoirs / Sin brazos / Without arms	
Visiteur 4 pieds Confidente 4 patas 4 Legs	1 U. / 1 U. / 1 chairs	90.711.219
	6 U. / 6 U. / 6 chairs	90.715.219
		90.002.001
Chairot de transport Carro para transportar sillas Trolley		

## FINITIONS | ACABADOS | FINISHES

STRUCTURE  
ARMAZÓN  
FRAME



Chromée  
Cromado  
Chrome

ASSISE ET DOSSIER: POLYPROPYLÈNE  
ASIENTO Y RESPALDO: POLIPROPILENO  
POLYPROPYLENE SEAT AND BACKREST



211  
Noir  
Negro  
Black



TABOURETS  
TABURETES  
STOOLS



352 | NO FRILL



358 | NUT

# NO-FRILL

Les tabourets NO FRILL élargissent la dimension des espaces conçus avec des tables hautes, donnant la possibilité de nouvelles applications dans le bureau.

Los taburetes NO FRILL amplían la dimensión de los espacios diseñados con mesas altas dando la posibilidad a nuevas aplicaciones en la oficina.

NO FRILL is a stool with a comfortable seat-shell, with high back to do tasks at a high table placed in informal working spaces.



| TABOURET GIRATOIRE  
| SUR ROULETTES

| GIRATORIO  
| CON RUEDAS

| SWIVEL STOOL  
| WITH WHEELS











| TABOURET 4 PIEDS

| TABURETE  
| CON 4 PATAS





| 4 LEGS STOOL







## MODÈLES | VARIANTES | VERSIONS

MODÈLE / VARIANTES / VERSIONS	TYPE / TIPO / TYPE	RÉFÉRENCE / REFERENCIA / CODE		
 C	Assise et dossier: en polypropylène Asiento y respaldo: en polipropileno Polypropylene seat and backrest	 160.201.-.-	 160.301.-.-	 160.401.-.-
 E	Assise: Tissu au choix. Dossier: en polypropylène Asiento: Tapizado a elegir. Respaldo: en polipropileno Upholstered seat. Polypropylene backrest	 160.201.-.-	 160.301.-.-	 160.401.-.-

Chaise 4 pieds  
Silla de 4 patas  
4 legs

MODÈLE / VARIANTES / VERSIONS	TYPE / TIPO / TYPE	RÉFÉRENCE / REFERENCIA / CODE		
 C	Assise et dossier: en polypropylène Asiento y respaldo: en polipropileno Polypropylene seat and backrest	 160.504.-.-		
 E	Assise: Tissu au choix. Dossier: en polypropylène Asiento: Tapizado a elegir. Respaldo: en polipropileno Upholstered seat. Polypropylene backrest	 160.504.-.-		

Giratoire sans accoudoirs, sur roulettes et avec repose-pieds.  
Giratoria sin brazos con ruedas y reposapiés  
Swivel stool without arms, with wheels and footrest.

MODÈLE / VARIANTES / VERSIONS	TYPE / TIPO / TYPE	RÉFÉRENCE / REFERENCIA / CODE		
 C	Assise et dossier: en polypropylène Asiento y respaldo: en polipropileno Polypropylene seat and backrest	 160.505.-.-		
 E	Assise: Tissu au choix. Dossier: en polypropylène Asiento: Tapizado a elegir. Respaldo: en polipropileno Upholstered seat. Polypropylene backrest	 160.505.-.-		

Giratoire sans accoudoirs, sur roulettes  
Giratoria sin brazos con ruedas  
Swivel stool without arms

## FINITIONS | ACABADOS | FINISHES

### STRUCTURE ESTRUCTURA FRAME

 Blanche  
Blanco  
White

 Graphite  
Grafito  
Graphite

 Chromée  
Cromado  
Chrome

### BASE BASE BASE

 Aluminium poli  
Aluminio pulido  
Polished aluminium

### TYPE TIPO TYPE

C

ASSISE ET DOSSIER: POLYPROPYLÈNE  
ASIENTO Y RESPALDO: POLIPROPILENO  
POLYPROPYLENE SEAT AND BACKREST

341 Bleu clair / Azul claro / Light blue  
281 Graphite / Grafito / Graphite  
271 Blanc / Blanco / White  
201 Orange / Naranja / Orange  
291 Bleu foncé / Azul oscuro / Dark blue  
241 Marron / Marrón / Beige  
211 Jaune / Amarillo / Yellow

### TYPE TIPO TYPE

E

DOSSIER EN POLYPROPYLÈNE  
RESPALDO EN POLIPROPILENO  
POLYPROPYLENE BACKREST

541 Bleu clair / Azul claro / Light blue  
881 Graphite / Grafito / Graphite  
871 Blanc / Blanco / White  
801 Orange / Naranja / Orange  
891 Bleu foncé / Azul oscuro / Dark blue  
841 Marron / Marrón / Beige  
811 Jaune / Amarillo / Yellow

ASSISE: TISSU AU CHOIX  
ASIENTO: TAPIZADO A ELEGIR  
UPHOLSTERED SEAT

 Cf. page 508  
Ver pagina 508  
See page 508

# Nut

Le tabouret NUT s'adapte à différents styles de bureau, idéal pour des espaces collectifs avec tables hautes.

El taburete NUT se adapta a diferentes estilos de oficina, de los más nórdicos a los más industriales. Son el aliado perfecto para espacios colectivos con mesas altas.

The NUT stool is suitable to many working environments, from the most Nordic to the most industrial. They are the perfect ally for collective spaces with high tables, for short meetings or for lunch.





STRUCTURE  
TRAÎNEAU EN  
BOIS NATUREL

ESTRUCTURA  
PATÍN EN HAYA  
NATURAL

WOODEN SLED  
FRAME STOOL







TABOURET  
PIÈTEMENT  
TRAÎNEAU CHROMÉ

TABURETE CON  
ESTRUCTURA  
PATÍN CROMADA

CHROME SLED  
FRAME STOOL



## MODÈLES | VARIANTES | VERSIONS

MODÈLE / VARIANTES / VERSIONS	TYPE / TIPO / TYPE	RÉFÉRENCE / REFERENCIA / CODE
	4 U. / 4 U. / 4 chairs Assise et dossier en polypropylène Asiento y respaldo en polipropileno Polypropylene seat and backrest	155.401. . . .
	4 U. / 4 U. / 4 chairs Assise et dossier seulement en polypropylène blanc Asiento y respaldo en polipropileno blanco White polypropylene seat and backrest	155.601.274

Tabouret  
Taburete  
Stool

## FINITIONS | ACABADOS | FINISHES

STRUCTURE  
ESTRUCTURA  
FRAME

ASSISE ET DOSSIER: POLYPROPYLÈNE  
ASIENTO Y RESPALDO: POLIPROPILENO  
POLYPROPYLENE SEAT AND BACKREST

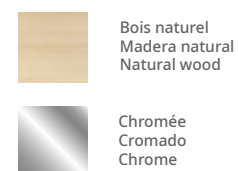

POUTRES  
BANCADAS  
BEAMS



368 | LED



372 | BROS



376 | TOM



380 | MARCO



384 | HITO



388 | NAVIA

# Led







Les poutres sont une solution efficace pour les centres de santé, les aéroports, les réceptions et les petites salles d'attente. Chaque poutre a une structure linéaire à laquelle s'ajoutent les assises et/ou table pour répondre aux besoins de l'espace.

Las bancadas son una solución eficaz para centros de salud, aeropuertos, recepciones y pequeñas salas de espera. Cada bancada dispone de una estructura lineal a la que se le añaden sus asientos y/o mesa para satisfacer las necesidades del espacio.





Benches are an effective solution for health centers, airports, reception areas and waiting rooms. Each bench has a beam on which the seats and / or table are fixed and so meet the needs of the space.



## MODÈLES | VARIANTES | VERSIONS

MODÈLE / VARIANTES / VERSIONS	TYPE / TIPO / TYPE	RÉFÉRENCE / REFERENCIA / CODE	
 A	Assise et dossier en tissu / Asiento y respaldo tapizado / Upholstered single shell	Sans accoudoirs / Sin brazos / Without arms Avec accoudoirs / Con brazos / Fixed arms	   67.611.-- 67.611.-- 67.611.-- 67.612.-- 67.612.-- 67.612.--
 C	Assise et dossier en polypropylène / Asiento y respaldo polipropilieno / Single shell polypropylene	Sans accoudoirs / Sin brazos / Without arms Avec accoudoirs / Con brazos / Fixed arms	67.611.-- 67.611.-- 67.611.-- 67.612.-- 67.612.-- 67.612.--
 G	Assise tissu et dossier en résille / Asiento tapizado y respaldo rejilla / Seat upholstered fabric and backrest black mesh	Sans accoudoirs / Sin brazos / Without arms Avec accoudoirs / Con brazos / Fixed arms	67.611.-- 67.611.-- 67.611.-- 67.612.-- 67.612.-- 67.612.--
 M	Assise tissu et dossier en flexpu / Asiento tapizado y respaldo flexpu / Seat upholstered fabric and backrest flexpu	Sans accoudoirs / Sin brazos / Without arms Avec accoudoirs / Con brazos / Fixed arms	67.611.-- 67.611.-- 67.611.-- 67.612.-- 67.612.-- 67.612.--

Assise et dossier  
Asiento y respaldo  
Seat and backrest

	2 places / 2 plazas / 2 seats 3 places / 3 plazas / 3 seats 4 places / 4 plazas / 4 seats 5 places / 5 plazas / 5 seats	  67.003.124 67.003.131 67.005.124 67.005.131 67.007.124 67.007.131 67.009.124 67.009.131	
	Structure poutre visée sol / Atornillada al suelo / Metal beam frame fixed to the floor	2 places / 2 plazas / 2 seats 3 places / 3 plazas / 3 seats 4 places / 4 plazas / 4 seats 5 places / 5 plazas / 5 seats	67.004.124 67.004.131 67.006.124 67.006.131 67.008.124 67.008.131 67.010.124 67.010.131

Structure poutre  
Estructura para bancadas  
Metal beam frame

## FINITIONS | ACABADOS | FINISHES

STRUCTURE  
ESTRUCTURA  
FRAME

	Noire Negro Black RAL 9005
	Argentée Plata Silver RAL 9006
	Chromée Chromado Chrome

TYPE A / TIPO A / TYPE A  
TYPE G / TIPO G / TYPE G  
TYPE M / TIPO M / TYPE M





















Cf. page 508  
Ver página 508  
See page 508

TYPE A / TIPO A / TYPE A	111	117	119
TYPE G / TIPO G / TYPE G	321	327	329
TYPE M / TIPO M / TYPE M	711	717	719

TYPE  
TIPO  
TYPE C

ASSISE ET DOSSIER: POLYSTYRÈNE  
ASIENTO Y RESPALDO: POLIESTIRENO  
SINGLE SHELL: POLYSTYRENE

 551	 655	 559	Jaune / Amarillo / Yellow
 541	 645	 549	Rouge / Rojo / Red
 521	 625	 529	Bleu / Azul / Blue
 531	 635	 539	Vert / Verde / Green
 581	 685	 589	Graphite / Grafito / Graphite
 571	 675	 579	Blanc / Blanco / White



# BROS

Les poutres sont une solution efficace pour les centres de santé, les aéroports, les réceptions et les petites salles d'attente. Chaque poutre a une structure linéaire à laquelle s'ajoutent les assises et/ou table pour répondre aux besoins de l'espace.





Las bancadas son una solución eficaz para centros de salud, aeropuertos, recepciones y pequeñas salas de espera. Cada bancada dispone de una estructura lineal a la que se le añaden sus asientos y/o mesa para satisfacer las necesidades del espacio.

Benches are an effective solution for health centers, airports, reception areas and waiting rooms. Each bench has a beam on which the seats and / or table are fixed and so meet the needs of the space.







# MODÈLES | VARIANTES | VERSIONS

MODÈLE / VARIANTES / VERSIONS	TYPE / TIPO / TYPE	RÉFÉRENCE / REFERENCIA / CODE
 N	Assise et dossier en tissu / Asiento y respaldo tapizado / Upholstered seat and backrest	 57.065.101
 O	Assise et dossier en PC+ABS/ Asiento y respaldo en PC+ABS / PC+ABS seat and backrest	57.064.---
 P	Assise tissu et dossier en PC+ABS / Asiento tapizado y respaldo en PC+ABS/ Upholstered seat and PC+ABS backrest	57.064.---

Assise et dossier  
Asiento y respaldo  
Seat and backrest

				
	2 places / 2 plazas / 2 seats	57.060.124	57.160.111	57.460.120
	3 places / 3 plazas / 3 seats	57.061.124	57.161.111	57.461.120
	4 places / 4 plazas / 4 seats	57.062.124	57.162.111	57.462.120
	5 places / 5 plazas / 5 seats	57.063.124	57.163.111	57.463.120
	2 places / 2 plazas / 2 seats			
	3 places / 3 plazas / 3 seats			
	4 places / 4 plazas / 4 seats			
	5 places / 5 plazas / 5 seats			
	2 places / 2 plazas / 2 seats			
	3 places / 3 plazas / 3 seats			
	4 places / 4 plazas / 4 seats			
	5 places / 5 plazas / 5 seats			

Structure poutre  
Estructura para bancadas  
Metal beam frame

				
	Jeu d'accoudoirs / Juego de brazos / Arm set	57.067.124	57.167.111	57.467.131
	Accoudoir droit / Brazo derecho / Right arm	57.068.124	57.168.111	57.468.131
	Accoudoir gauche / Brazo izquierdo / Left arm	57.069.124	57.169.111	57.469.131

Accoudoirs pour poutres  
Brazos para bancadas  
Armrests

# FINITIONS | ACABADOS | FINISHES

## STRUCTURE ESTRUCTURA FRAME

-  Noire + noir  
Negro + negro  
Black + black  
RAL 9005
-  Argentée + argent  
Plata + plata  
Silver + silver  
RAL 9006
-  Argentée + chromé  
Plata + cromado  
Silver + chrome

## TYPE TIPO TYPE

N







ASSISE ET DOSSIER: TISSU AU CHOIX  
ASIENTO Y RESPALDO: TAPIZADO A ELEGIR  
UPHOLSTERED SEAT AND BACKREST

 Cf. page 508  
Ver página 508  
See page 508

## TYPE TIPO TYPE

O







ASSISE ET DOSSIER EN PC+ABS  
ASIENTO Y RESPALDO EN PC+ABS  
PC+ABS SEAT AND BACKREST

-  211 Noir  
Negro  
Black
-  271 Blanc  
Blanco  
White
-  221 Bleu  
Azul  
Blue
-  241 Rouge  
Rojo  
Red
-  231 Vert pistache  
Verde pistacho  
Pistachio green
-  281 Graphite  
Grafito  
Graphite
-  461 Imitation Chêne  
Imitación Roble  
Maple imitation

## TYPE TIPO TYPE

P

DOSSIER EN PC+ABS  
RESPALDO EN PC+ABS  
PC+ABS BACKREST

-  811 Noir  
Negro  
Black
-  871 Blanc  
Blanco  
White
-  821 Bleu  
Azul  
Blue
-  841 Rouge  
Rojo  
Red
-  831 Vert pistache  
Verde pistacho  
Pistachio green
-  881 Graphite  
Grafito  
Graphite
-  471 Imitation Chêne  
Imitación Roble  
Maple imitation

ASSISE: TISSU AU CHOIX  
ASIENTO: TAPIZADO A ELEGIR  
UPHOLSTERED SEAT

 Cf. page 508  
Ver página 508  
See page 508





# Tom



Les poutres sont une solution efficace pour les centres de santé, les aéroports, les réceptions et les petites salles d'attente. Chaque poutre a une structure linéaire à laquelle s'ajoutent les assises et/ou table pour répondre aux besoins de l'espace.

Las bancadas son una solución eficaz para centros de salud, aeropuertos, recepciones y pequeñas salas de espera. Cada bancada dispone de una estructura lineal a la que se le añaden sus asientos y/o mesa para satisfacer las necesidades del espacio.

Benches are an effective solution for health centers, airports, reception areas and waiting rooms. Each bench has a beam on which the seats and / or table are fixed and so meet the needs of the space.



# MODÈLES | VARIANTES | VERSIONS

MODÈLE / VARIANTES / VERSIONS	TYPE / TIPO / TYPE	RÉFÉRENCE / REFERENCIA / CODE
 B	Assise et dossier en tissu / Asiento y respaldo tapizados / Upholstered seat and backrest	142.061.---
 C	Assise et dossier en polypropylène / Asiento y respaldo polipropileno / Single shell polypropylene	142.061.---
 E	Assise tissu et dossier en polypropylène / Asiento tapizado y respaldo polipropileno / Seat upholstered fabric and backrest: polypropylene	142.061.---

Assise et dossier  
Asiento y respaldo  
Seat and backrest

	2 places / 2 plazas / 2 seats 3 places / 3 plazas / 3 seats 4 places / 4 plazas / 4 seats 5 places / 5 plazas / 5 seats	Sans accoudoirs / Sin brazos / Without arms	142.621.120 142.631.120 142.641.120 142.651.120
	2 places / 2 plazas / 2 seats 3 places / 3 plazas / 3 seats 4 places / 4 plazas / 4 seats 5 places / 5 plazas / 5 seats	Accoudoirs fixes / Con brazos / Fixed arms	142.622.120 142.632.120 142.642.120 142.652.120

Structure poutre  
Estructura para bancadas  
Metal beam frame



# FINITIONS | ACABADOS | FINISHES

## STRUCTURE ESTRUCTURA FRAME

 Noire + noir  
Negro + negro  
Black + black  
RAL 9005

 Noire + chromé  
Negro + cromado  
Black + chrome

TYPE  
TIPO  
TYPE

B

ASSISE ET DOSSIER: TISSU AU CHOIX  
ASIENTO Y RESPALDO: TAPIZADO A ELEGIR  
UPHOLSTERED SEAT AND BACKREST

101



Cf. page 508  
Ver página 508  
See page 508

TYPE  
TIPO  
TYPE

C

ASSISE ET DOSSIER: POLYPROPYLÈNE  
ASIENTO Y RESPALDO: POLIPROPILENO  
POLYPROPYLENE SEAT AND BACKREST

211 Noir  
Negro  
Black

271 Blanc  
Blanco  
White

221 Bleu  
Azul  
Blue

241 Rouge  
Rojo  
Red

281 Gris  
Gris  
Grey

TYPE  
TIPO  
TYPE

E

DOSSIER: POLYPROPYLÈNE  
RESPALDO: POLIPROPILENO  
POLYPROPYLENE BACKREST

811 Noir  
Negro  
Black

871 Blanc  
Blanco  
White

821 Bleu  
Azul  
Blue

841 Rouge  
Rojo  
Red

861 Gris  
Gris  
Grey

ASSISE: TISSU AU CHOIX  
ASIENTO: TAPIZADO A ELEGIR  
UPHOLSTERED SEAT



Cf. page 508  
Ver página 508  
See page 508

# Marco





Les poutres sont une solution efficace pour les centres de santé, les aéroports, les réceptions et les petites salles d'attente. Chaque poutre a une structure linéaire à laquelle s'ajoutent les assises et/ou table pour répondre aux besoins de l'espace.

Las bancadas son una solución eficaz para centros de salud, aeropuertos, recepciones y pequeñas salas de espera. Cada bancada dispone de una estructura lineal a la que se le añaden sus asientos y/o mesa para satisfacer las necesidades del espacio.





Benches are an effective solution for health centers, airports, reception areas and waiting rooms. Each bench has a beam on which the seats and / or table are fixed and so meet the needs of the space.



# MODÈLES | VARIANTES | VERSIONS

MODÈLE / VARIANTES / VERSIONS	TYPE / TIPO / TYPE	RÉFÉRENCE / REFERENCIA / CODE
 B	Assise et dossier en tissu / Asiento y respaldo tapizados / Upholstered single shell	87.611.--
 C	Assise et dossier en polypropylène / Asiento y respaldo polipropileno / Single shell polypropylene	87.611.--
 E	Assise tissu et dossier en polypropylène / Asiento tapizado y respaldo polipropileno / Seat upholstered fabric and backrest polypropylene	87.611.--
 I	Contre-plaqué / Madera laminada / Single shell wood	87.611.--





Assise et dossier  
Asiento y respaldo  
Seat and backrest

		2 places / 2 plazas / 2 seats 3 places / 3 plazas / 3 seats 4 places / 4 plazas / 4 seats 5 places / 5 plazas / 5 seats	 66.631.124 66.631.131 66.641.124 66.641.131 66.651.124 66.651.131 66.661.124 66.661.131
	Structure poutre visée sol/ Atornillada al suelo / Metal beam frame fixed to the floor	2 places / 2 plazas / 2 seats 3 places / 3 plazas / 3 seats 4 places / 4 plazas / 4 seats 5 places / 5 plazas / 5 seats	 66.632.124 66.632.131 66.642.124 66.642.131 66.652.124 66.652.131 66.662.124 66.662.131

Structure poutre  
Estructura para bancadas  
Metal beam frame



# FINITIONS | ACABADOS | FINISHES

STRUCTURE ESTRUCTURA FRAME	TYPE TIPO TYPE	ASSISE ET DOSSIER: TISSU AU CHOIX ASIENTO Y RESPALDO: TAPIZADO A ELEGIR UPHOLSTERED SEAT AND BACKREST		Cf. page 508 Ver pagina 508 See page 508	<b>101</b>
 Noire + noir Negro + negro Black + black RAL 9005	TYPE TIPO TYPE	ASSISE ET DOSSIER: POLYPROPYLÈNE ASIENTO Y RESPALDO: POLIPROPILENO SINGLE SHELL: POLYPROPYLENE	<b>211</b> Noir Negro Black	<b>221</b> Bleu Azul Blue	<b>231</b> Vert Verde Green
 Noire + chromé Negro + cromado Black + chrome	TYPE TIPO TYPE	ASSISE: TISSU AU CHOIX ASIENTO: TAPIZADO A ELEGIR UPHOLSTERED SEAT		Cf. page 508 Ver pagina 508 See page 508	<b>301</b>
	TYPE TIPO TYPE	ASSISE ET DOSSIER CONTRE-PLAQUÉ ASIENTO Y RESPALDO MADERA LÁMINADA SINGLE SHELL WOOD	<b>411</b> Hêtre Naturel Haya natural Natural beech	<b>421</b> Poirier Peral Pear	<b>431</b> Vert Verde Green
			<b>441</b> Bleu Azul Blue		

DOSSIER EN POLYPROPYLÈNE NOIRE  
RESPALDO EN POLIPROPILENO NEGRO  
BACKREST: POLYPROPYLENE

# Hito

Les poutres sont une solution efficace pour les centres de santé, les aéroports, les réceptions et les petites salles d'attente. Chaque poutre a une structure linéaire à laquelle s'ajoutent les assises et/ou table pour répondre aux besoins de l'espace.

Las bancadas son una solución eficaz para centros de salud, aeropuertos, recepciones y pequeñas salas de espera. Cada bancada dispone de una estructura lineal a la que se le añaden sus asientos y/o mesa para satisfacer las necesidades del espacio.

Benches are an effective solution for health centers, airports, reception areas and waiting rooms. Each bench has a beam on which the seats and / or table are fixed and so meet the needs of the space.





## MODÈLES | VARIANTES | VERSIONS

MODÈLE / VARIANTES / VERSIONS	TYPE / TIPO / TYPE	RÉFÉRENCE / REFERENCIA / CODE												
 C Assise et dossier Asiento y respaldo Seat and backrest	Assise et dossier en polypropylène / Asiento y respaldo polipropileno / Single shell polypropylene	66.611.--												
 Structure poutre Estructura para bancadas Metal beam frame	Structure poutre visée sol/ Atornillada al suelo / Metal beam frame fixed to the floor	<table border="0"> <tr> <td>2 places / 2 plazas / 2 seats</td> <td>66.631.124</td> <td>66.631.131</td> </tr> <tr> <td>3 places / 3 plazas / 3 seats</td> <td>66.641.124</td> <td>66.641.131</td> </tr> <tr> <td>4 places / 4 plazas / 4 seats</td> <td>66.651.124</td> <td>66.651.131</td> </tr> <tr> <td>5 places / 5 plazas / 5 seats</td> <td>66.661.124</td> <td>66.661.131</td> </tr> </table>	2 places / 2 plazas / 2 seats	66.631.124	66.631.131	3 places / 3 plazas / 3 seats	66.641.124	66.641.131	4 places / 4 plazas / 4 seats	66.651.124	66.651.131	5 places / 5 plazas / 5 seats	66.661.124	66.661.131
2 places / 2 plazas / 2 seats	66.631.124	66.631.131												
3 places / 3 plazas / 3 seats	66.641.124	66.641.131												
4 places / 4 plazas / 4 seats	66.651.124	66.651.131												
5 places / 5 plazas / 5 seats	66.661.124	66.661.131												

## FINITIONS | ACABADOS | FINISHES

### STRUCTURE ESTRUCTURA FRAME

 Noire + noir  
 Negro + negro  
 Black + black  
RAL 9005

 Noire + chromé  
 Negro + cromado  
 Black + chrome

### ASSISE ET DOSSIER EN POLYPROPYLÈNE ASIENTO Y RESPALDO POLIPROPILENO POLYPROPYLENE SEAT AND BACKREST

 211 Noir  
 Negro Black

 221 Bleu  
 Azul Blue

 231 Vert  
 Verde Green

 281 Graphite  
 Grafito Graphite

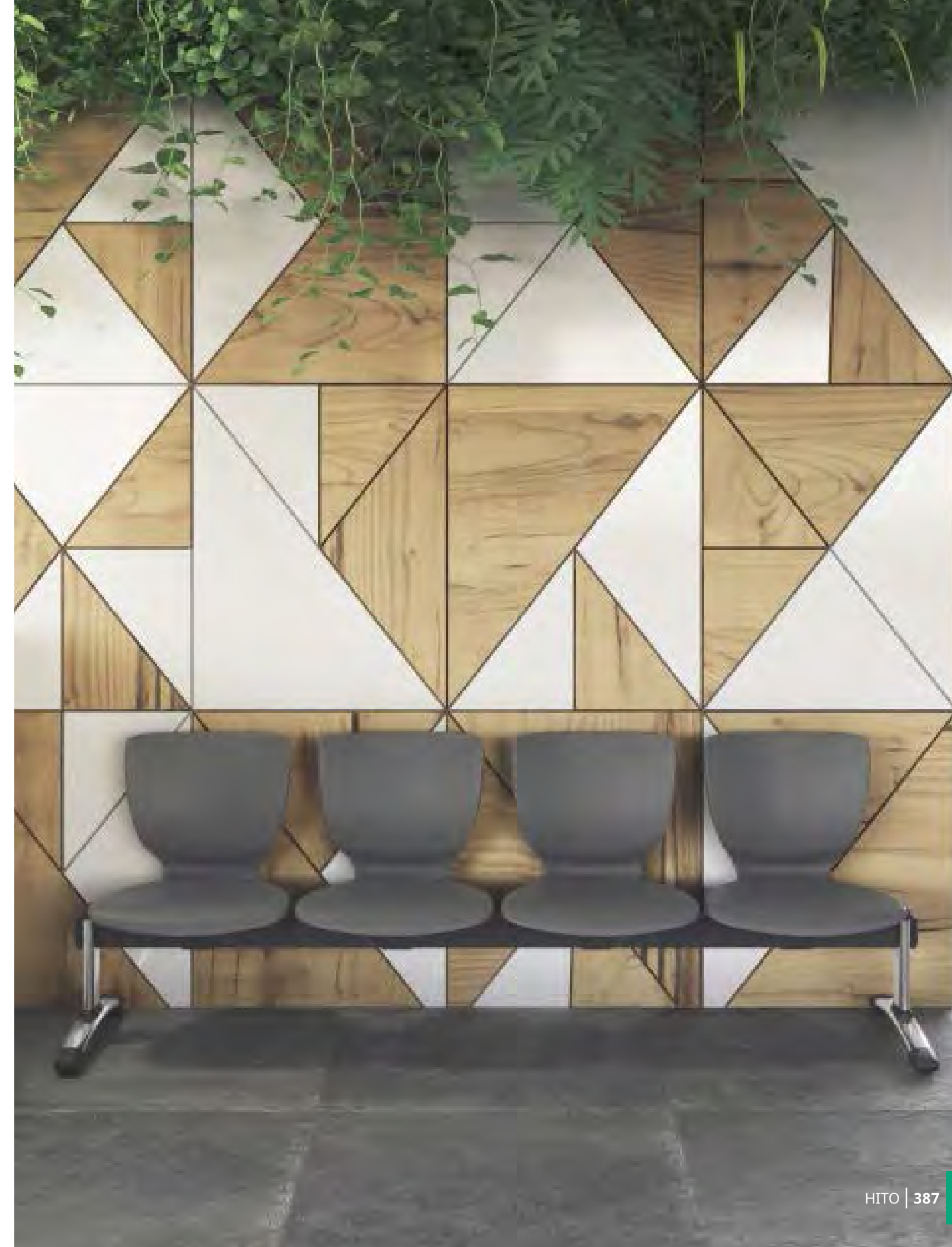

# Navia

Les poutres sont une solution efficace pour les centres de santé, les aéroports, les réceptions et les petites salles d'attente. Chaque poutre a une structure linéaire à laquelle s'ajoutent les assises et/ou table pour répondre aux besoins de l'espace.

Las bancadas son una solución eficaz para centros de salud, aeropuertos, recepciones y pequeñas salas de espera. Cada bancada dispone de una estructura lineal a la que se le añaden sus asientos y/o mesa para satisfacer las necesidades del espacio.

Benches are an effective solution for health centers, airports, reception areas and waiting rooms. Each bench has a beam on which the seats and / or table are fixed and so meet the needs of the space.



## MODÈLES | VARIANTES | VERSIONS

MODÈLE / VARIANTES / VERSIONS	TYPE / TIPO / TYPE	RÉFÉRENCE / REFERENCIA / CODE
 C	Contre-plaqué / Madera laminada / Single shell wood	88.611.-

Assise et dossier  
Asiento y respaldo  
Seat and backrest

Structure poutre Estructura para bancadas Metal beam frame	Structure poutre visée sol/ Atornillada al suelo / Metal beam frame fixed to the floor		
		2 places / 2 plazas / 2 seats 3 places / 3 plazas / 3 seats 4 places / 4 plazas / 4 seats 5 places / 5 plazas / 5 seats	2 places / 2 plazas / 2 seats 3 places / 3 plazas / 3 seats 4 places / 4 plazas / 4 seats 5 places / 5 plazas / 5 seats

## FINITIONS | ACABADOS | FINISHES

STRUCTURE  
ESTRUCTURA  
FRAME

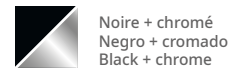
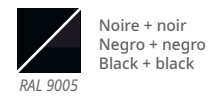

ASSISE ET DOSSIER CONTRE-PLAQUÉ  
ASIENTO Y RESPALDO MADERA LAMINADA  
WOOD SHELL





MOBILIER D'AMPHITHÉÂTRE  
PUPITRES  
CLASSROOM BENCH



394 | IVOK

# ivok

Pupitres multifonctions conçus pour plusieurs espaces de travail comme les universités, salles de conférences, etc...

Pupitres multifuncionales destinados a diferentes espacios de trabajo. Con ellos podemos instalar tanto centros Universitarios como salas de conferencias.

Classroom bench for different spaces: lecture and auditorium halls, conference rooms in universities and educational centers.





Plateau droit rabattable  
Sobre recto abatible  
Straight folding desktop



Plateau postformé rabattable  
Sobre post-formado abatible  
Post-formed folding desktop

PLATEAU  
RABATTABLE

SOBRE  
ABATIBLE

FOLDING  
DESKTOP



POUR PERSONNES  
À MOBILITÉ  
RÉDUITE (PMR)

PARA PERSONAS  
CON MOVILIDAD  
REDUCIDA

WHEELCHAIR  
ACCESS





| PLATEAU FIXE

| SOBRE FIJO

| FIXED DESKTOP



Plateau droit fixe  
Sobre recto fijo  
Straight fixed desktop



Plateau postformé fixe  
Sobre post-formado fijo  
Fixed post-formed desktop



POUTRE  
INDIVIDUELLE

PUPITRE  
INDIVIDUAL

SINGLE  
CHAIR



Élément final individuel  
Final individual  
End-individual single chair

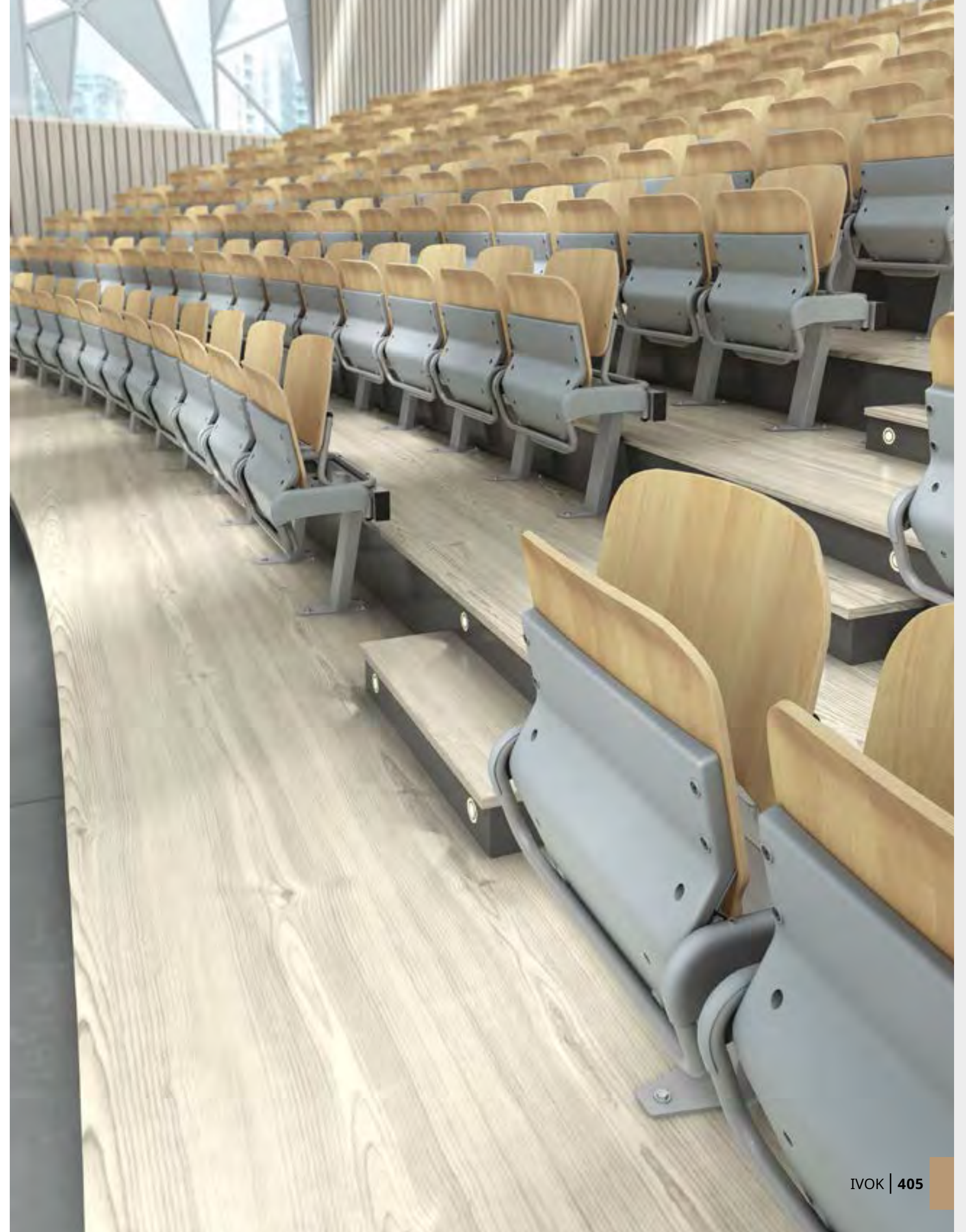

# MODÈLES | VARIANTES | VERSIONS

## PLATEAU FIXE / SOBRES FIJO / FIXED DESK TOP

MODÈLE / VARIANTES / VERSIONS	TYPE / TIPO / TYPE	RÉFÉRENCE / REFERENCIA / CODE
	Élément final	2 places / 2 plazas / 2 seats 581.112.111
	Pupitre final	3 places / 3 plazas / 3 seats 581.111.111
	End table	4 places / 4 plazas / 4 seats 581.110.111
	Élément intermédiaire	2 places / 2 plazas / 2 seats 581.108.-.-
	Pupitre intermedio	3 places / 3 plazas / 3 seats 581.107.-.-
	Middle table	4 places / 4 plazas / 4 seats 581.106.-.-
	Élément départ	2 places / 2 plazas / 2 seats 581.104.-.-
	Pupitre inicial	3 places / 3 plazas / 3 seats 581.103.-.-
	Start table	4 places / 4 plazas / 4 seats 581.102.-.-

**Poutre terminale**  
**Pupitres terminales**  
**End tables**

	Élément final	5 places / 5 plazas / 5 seats 581.136.111
	Pupitre final	6 places / 6 plazas / 6 seats 581.135.111
	End table	8 places / 8 plazas / 8 seats 581.134.111
	Élément intermédiaire	5 places / 5 plazas / 5 seats 581.132.-.-
	Pupitre intermedio	6 places / 6 plazas / 6 seats 581.131.-.-
	Middle table	8 places / 8 plazas / 8 seats 581.130.-.-
	Élément départ	5 places / 5 plazas / 5 seats 581.128.-.-
	Pupitre inicial	6 places / 6 plazas / 6 seats 581.127.-.-
	Start table	8 places / 8 plazas / 8 seats 581.126.-.-

**Poutre double**  
**Pupitres doubles**  
**Side by side tables**

	Élément final	2 places / 2 plazas / 2 seats 581.148.111
	Pupitre final	3 places / 3 plazas / 3 seats 581.147.111
	End table	4 places / 4 plazas / 4 seats 581.146.111
	Élément intermédiaire	2 places / 2 plazas / 2 seats 581.144.-.-
	Pupitre intermedio	3 places / 3 plazas / 3 seats 581.143.-.-
	Middle table	4 places / 4 plazas / 4 seats 581.142.-.-
	Élément départ	2 places / 2 plazas / 2 seats 581.140.-.-
	Pupitre inicial	3 places / 3 plazas / 3 seats 581.139.-.-
	Start table	4 places / 4 plazas / 4 seats 581.138.-.-

**Poutre centrale**  
**Pupitres centrales**  
**Add-on tables**

## FINITIONS | ACABADOS | FINISHES

### STRUCTURE ESTRUCTURA FRAME

	Noire Negro Black
	Argentée Plata Silver

### ASSISE ASIENTO SEAT

	Blanc Blanco White		Gris Gris Grey		Hêtre Haya Beech		Chêne Moyen Roble Maple
	Poirier Peral Pear		Wengué Wengue Wengue		Acacia Clair Acacia Clara Light Acacia		Acacia Foncé Acacia Oscura Dark Acacia

# MODÈLES | VARIANTES | VERSIONS

## PLATEAU RABATTABLE / SOBRES ABATIBLE / FOLDING DESK TOP

MODÈLE / VARIANTES / VERSIONS	TYPE / TIPO / TYPE	RÉFÉRENCE / REFERENCIA / CODE
	Élément final	2 places / 2 plazas / 2 seats 581.112.111
	Pupitre final	3 places / 3 plazas / 3 seats 581.111.111
	End table	4 places / 4 plazas / 4 seats 581.110.111
	Élément intermédiaire	2 places / 2 plazas / 2 seats 581.120.-.-
	Pupitre intermedio	3 places / 3 plazas / 3 seats 581.119.-.-
	Middle table	4 places / 4 plazas / 4 seats 581.118.-.-
	Élément départ	2 places / 2 plazas / 2 seats 581.116.-.-
	Pupitre inicial	3 places / 3 plazas / 3 seats 581.115.-.-
	Start table	4 places / 4 plazas / 4 seats 581.114.-.-

**Poutre terminale**  
**Pupitres terminales**  
**End tables**

	Élément final	5 places / 5 plazas / 5 seats 581.136.111
	Pupitre final	6 places / 6 plazas / 6 seats 581.135.111
	End table	8 places / 8 plazas / 8 seats 581.134.111
	Élément intermédiaire	5 places / 5 plazas / 5 seats 581.156.-.-
	Pupitre intermedio	6 places / 6 plazas / 6 seats 581.155.-.-
	Middle table	8 places / 8 plazas / 8 seats 581.154.-.-
	Élément départ	5 places / 5 plazas / 5 seats 581.152.-.-
	Pupitre inicial	6 places / 6 plazas / 6 seats 581.151.-.-
	Start table	8 places / 8 plazas / 8 seats 581.150.-.-

**Poutre double**  
**Pupitres doubles**  
**Side by side tables**

	Élément final	2 places / 2 plazas / 2 seats 581.148.111
	Pupitre final	3 places / 3 plazas / 3 seats 581.147.111
	End table	4 places / 4 plazas / 4 seats 581.146.111
	Élément intermédiaire	2 places / 2 plazas / 2 seats 581.168.-.-
	Pupitre intermedio	3 places / 3 plazas / 3 seats 581.167.-.-
	Middle table	4 places / 4 plazas / 4 seats 581.166.-.-
	Élément départ	2 places / 2 plazas / 2 seats 581.164.-.-
	Pupitre inicial	3 places / 3 plazas / 3 seats 581.163.-.-
	Start table	4 places / 4 plazas / 4 seats 581.162.-.-

**Poutre centrale**  
**Pupitres centrales**  
**Add-on tables**

## FINITIONS | ACABADOS | FINISHES

### STRUCTURE ESTRUCTURA FRAME

	Noire Negro Black
	Argentée Plata Silver

### ASSISE ASIENTO SEAT

	Blanc Blanco White		Gris Gris Grey		Hêtre Haya Beech		Chêne Moyen Roble Maple
	Poirier Peral Pear		Wengué Wengue Wengue		Acacia Clair Acacia Clara Light Acacia		Acacia Foncé Acacia Oscura Dark Acacia



# MODÈLES | VARIANTES | VERSIONS

PLATEAU RABATTABLE / SOBRE ABATIBLE / FOLDING DESK TOP

MODÈLE / VARIANTES / VERSIONS	TYPE / TIPO / TYPE	RÉFÉRENCE / REFERENCIA / CODE
-------------------------------	--------------------	-------------------------------



1 places / 1 plazas / 1 seats

581.073.111

581.073.124

Poutre individuelle  
Pupitre individual  
Single chair



Élément départ  
Pupitre inicial  
Start table

1 places / 1 plazas / 1 seats  
2 places / 2 plazas / 2 seats  
3 places / 3 plazas / 3 seats

581.172.---

581.072.---

581.171.---

581.071.---

581.170.---

581.070.---

Gamme PMR  
Gama movilidad reducida  
For wheelchair access

# FINITIONS | ACABADOS | FINISHES

STRUCTURE  
ESTRUCTURA  
FRAME

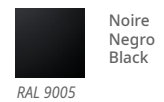

Noire  
Negro  
Black

RAL 9005



Argentée  
Plata  
Silver

RAL 9006

ASSISE  
ASIENTO  
SEAT



053 Blanc  
Blanco  
White



054 Gris  
Gris  
Grey



055 Hêtre  
Haya  
Beech



061 Chêne Moyen  
Roble  
Maple



062 Poirier  
Pera  
Pear



116 Wengué  
Wengue  
Wengue



103 Acacia Clair  
Acacia Clara  
Light Acacia



104 Acacia Foncé  
Acacia Oscura  
Dark Acacia



SOFT SEATING  
SOFT SEATING  
SOFT SEATING



412 | PUSH



426 | PLANER



442 | SF 1



446 | SF 2



450 | SF 3



456 | MR. JONES



464 | NEST



472 | RAN



484 | STORN



496 | TILOS

# PUSH

Une nouvelle tendance de canapés avec une capacité d'absorption acoustique fournit non seulement une isolation acoustique à l'intérieur de la capsule, mais contribue également à une meilleure acoustique de la pièce lorsqu'elle est stratégiquement placée.

Push vous permet de jouer avec ses options pour renforcer la marque et donner une touche sophistiquée au bureau.

Una nueva tendencia de soft seating ha venido para quedarse. Su capacidad fonoabsorbente no solo aísla acústicamente en el interior de la cápsula, también contribuye a una mejor acústica de la sala cuando se coloca de forma estratégica.

Este sofá permite jugar con sus opciones de tapicería para reforzar la marca y darle un toque sofisticado a la oficina.

By being able to focus and concentrate in open spaces, PUSH sofa and its sound absorption capabilities not only insulate acoustically within the pod, but also contribute to better room acoustics when strategically placed.

With a big number of color combinations, the high and low back Push sofa will always fit perfectly into the company environment.

CANAPÉS  
ACOUSTIQUES

SOFÁS  
ACÚSTICOS

ACOUSTIQUE  
SOFAS

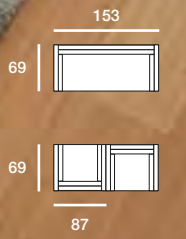



ENSEMBLE DE  
4 PLACES

CONJUNTO  
4 PLAZAS

4 SEATS  
MEETING POD

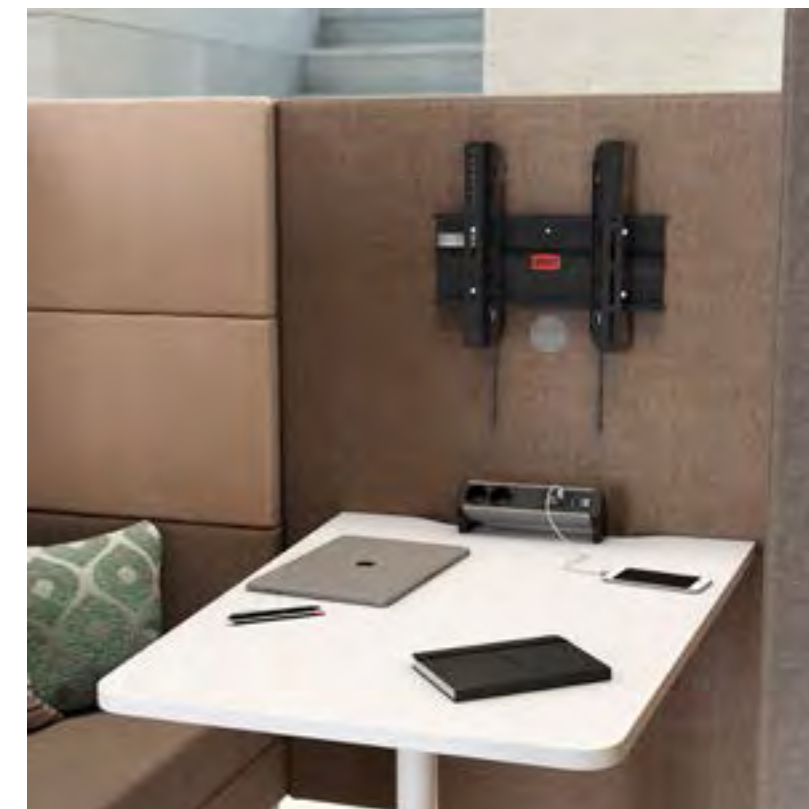

Complément: Support écran.  
Complemento: Soporte pantalla.  
Complement: TV support.

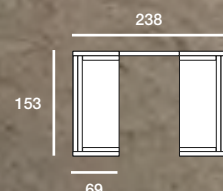

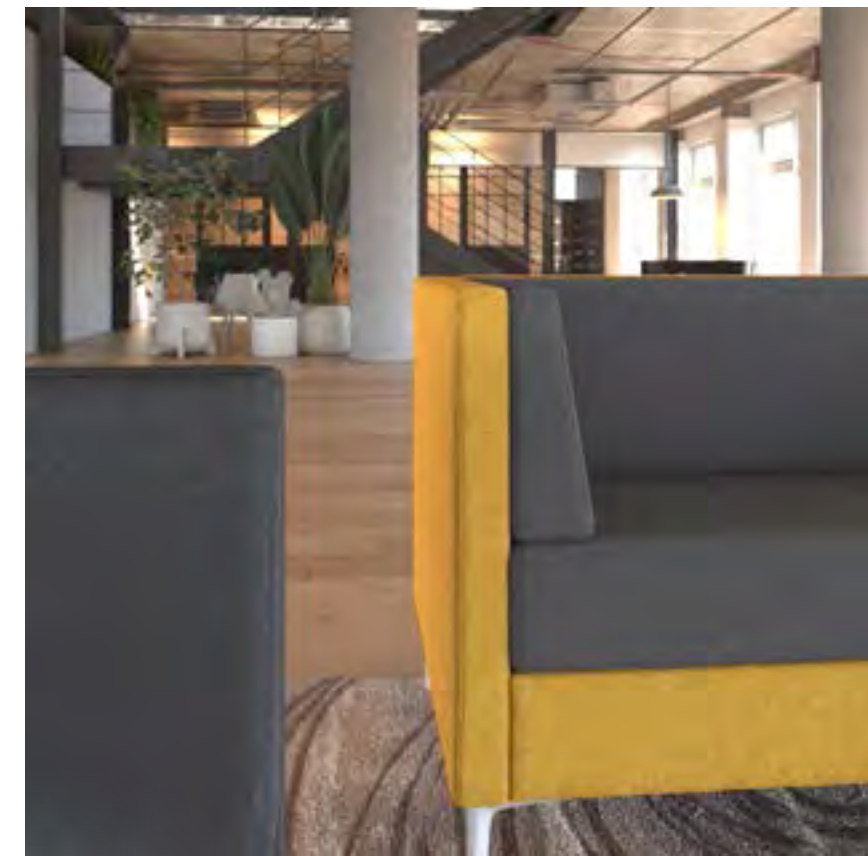

Option CONFORT.  
Opción CONFORT.  
COMFORT type.



Option BASIC.  
Opción BASIC.  
BASIC type.

| CANAPÉS

| SOFÁS

| SOFAS

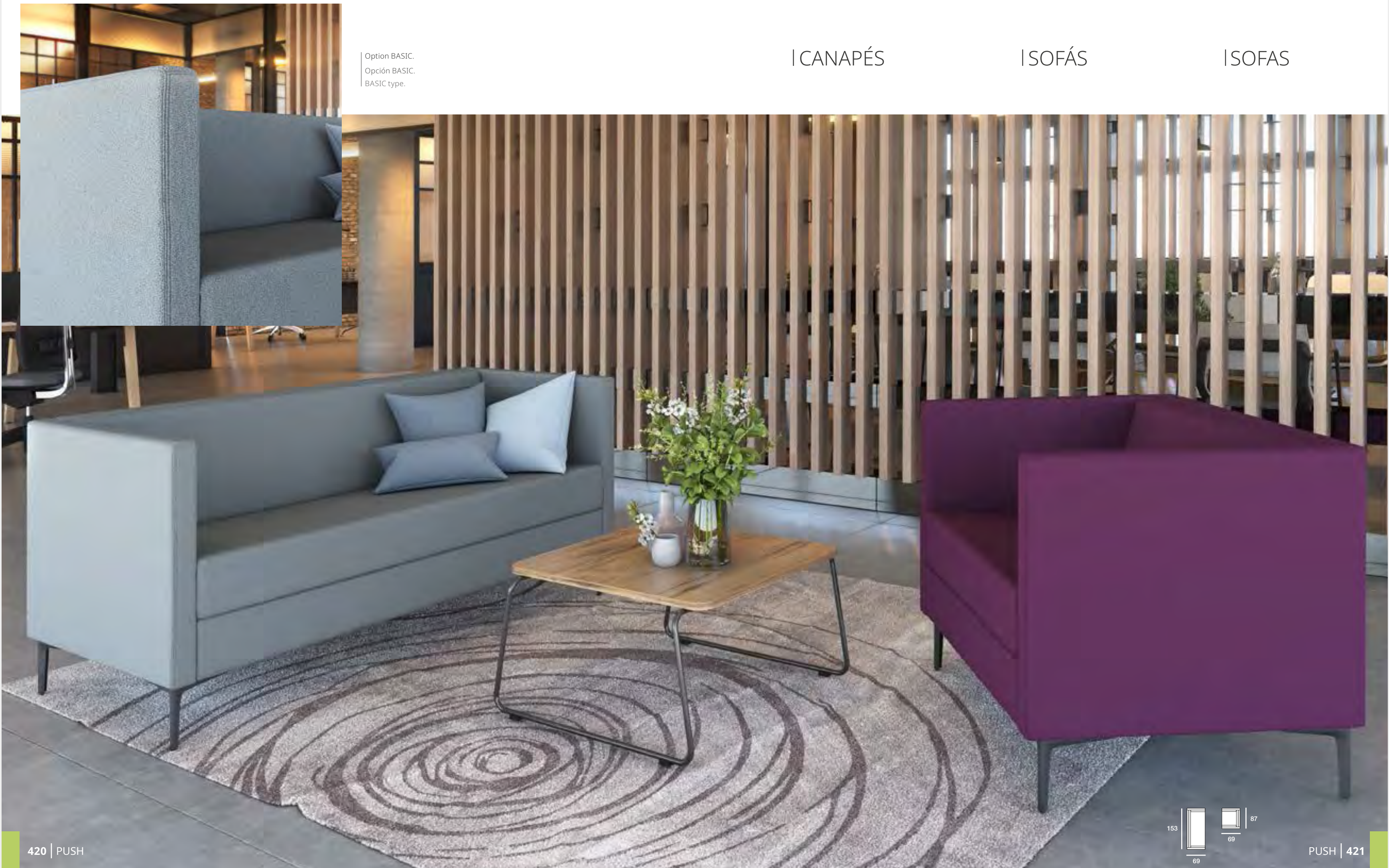

# MODÈLES | VARIANTES | VERSIONS

## CANAPÉ CONFORT / SOFÁ CONFORT / BASIC COMFORT

MODÈLE / VARIANTES / VERSIONS	DIMENSIONS / MEDIDAS / MEASUREMENTS	RÉFÉRENCE / REFERENCIA / CODE
	Prof./ Depth. 69 cm    L.87 H.71 cm	174.607.100   174.607.101   174.607.102   174.607.703
1 place 1 plaza 1 seat		

	Prof./ Depth. 69 cm    L.153 H.71 cm	174.608.100   174.608.101   174.608.102   174.608.703
2 places 2 plazas 2 seater		

## CANAPÉ BASIC / SOFÁ BASIC / BASIC SEATER

MODÈLE / VARIANTES / VERSIONS	DIMENSIONS / MEDIDAS / MEASUREMENTS	RÉFÉRENCE / REFERENCIA / CODE
	Prof./ Depth. 69 cm    L.87 H.71 cm	174.602.100   174.602.101   174.602.102   174.602.703
1 place 1 plaza 1 seat		

	Prof./ Depth. 69 cm    L.153 H.71 cm	174.603.100   174.603.101   174.603.102   174.603.703
2 places 2 plazas 2 seater		

## CANAPÉ HAUT CONFORT / SOFÁ ALTO CONFORT / HIGH BASIC COMFORT

MODÈLE / VARIANTES / VERSIONS	DIMENSIONS / MEDIDAS / MEASUREMENTS	RÉFÉRENCE / REFERENCIA / CODE
	Prof./ Depth. 69 cm    L.87 H.149 cm	174.617.100   174.617.101   174.617.102   174.617.703
1 place 1 plaza 1 seat		

	Prof./ Depth. 69 cm    L.153 H.149 cm	174.618.100   174.618.101   174.618.102   174.618.703
2 places 2 plazas 2 seater		

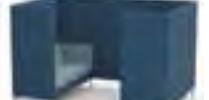
	Prof./ Depth. 153 cm    L.149 H.238 cm	174.632.100   174.632.101   174.632.102   174.632.703
Ensemble 4 places Conjunto 4 plazas Meeting pod (4 seats)		

## CANAPÉ HAUT BASIC / SOFÁ ALTO BASIC / HIGH BASIC SEATER

MODÈLE / VARIANTES / VERSIONS	DIMENSIONS / MEDIDAS / MEASUREMENTS	RÉFÉRENCE / REFERENCIA / CODE
	Prof./ Depth. 69 cm    L.87 H.149 cm	174.612.100   174.612.101   174.612.102   174.612.703
1 place 1 plaza 1 seat		

	Prof./ Depth. 69 cm    L.153 H.149 cm	174.613.100   174.613.101   174.613.102   174.613.703
2 places 2 plazas 2 seater		

	Prof./ Depth. 153 cm    L.149 H.238 cm	174.630.100   174.630.101   174.630.102   174.630.703
Ensemble 4 places Conjunto 4 plazas Meeting pod (4 seats)		



# MODÈLES | VARIANTES | VERSIONS

## CANAPÉ HAUT ACOUSTIQUE / SOFÁ ALTO ACÚSTICO / HIGH SEATER ACOUSTIC

MODÈLE / VARIANTES / VERSIONS	DIMENSIONS / MEDIDAS / MEASUREMENTS	RÉFÉRENCE / REFERENCIA / CODE
 1 place 1 plaza 1 seat	Prof./ Depth. 69 cm      L.87 H.149 cm	 174.627.100   174.627.101   174.627.102   174.627.703
 2 places 2 plazas 2 seater	Prof./ Depth. 69 cm      L.153 H.149 cm	174.628.100   174.628.101   174.628.102   174.628.703
 Ensemble 4 places Conjunto 4 plazas Meeting pod (4 seats)	Prof./ Depth. 153 cm      L.149 H.238 cm	174.634.100   174.634.101   174.634.102   174.634.703

## COUSSINS SUPÉRIEURS / COJINES SUPERIORES / UPHOLSTERED PANELS

MODÈLE / VARIANTES / VERSIONS	DIMENSIONS / MEDIDAS / MEASUREMENTS	RÉFÉRENCE / REFERENCIA / CODE
 1 place 1 plaza 1 seat	Prof./ Depth. 69 cm      L.87 H.149 cm	1.174.650.000
 2 places 2 plazas 2 seater	Prof./ Depth. 69 cm      L.153 H.149 cm	1.174.651.000
 Ensemble 4 places Conjunto 4 plazas Meeting pod (4 seats)	Prof./ Depth. 153 cm      L.149 H.238 cm	174.652.000

# FINITIONS | ACABADOS | FINISHES

## FINITION PIEDS ACABADO PIES LEG FINISHES

 Noire  
Negro  
Black  
RAL 9005

 Argentée  
Plata  
Silver  
RAL 9006



 Blanc  
Blanco  
White  
RAL 9016

 Graphite  
Grafito  
Graphite  
RAL 7022

## TISSU AU CHOIX TAPIZADO A ELEGIR UPHOLSTERED

 Cf. page 508  
Ver pagina 508  
See page 508

# COMPLÉMENTS | COMPLEMENTOS | COMPLEMENTS

MODÈLE / VARIANTES / VERSIONS	DIMENSIONS / MEDIDAS / MEASUREMENTS	RÉFÉRENCE / REFERENCIA / CODE - PVP / PVP / RRP
 Table Mesa Table	Prof./ Depth. 100 cm      L.75 H.75 cm	 174.080.---   174.180.---   174.280.---   174.380.---
 Table auxiliaire Mesa auxiliar Laptop table	Prof./ Depth. 45 cm      L.60 H.73 cm	174.083.---   174.183.---   174.283.---   174.383.---

# FINITIONS | ACABADOS | FINISHES

## PLATEAU / SOBRES / TOP

 007 Graphite  
Grafito  
Graphite

 051 Argent  
Plata  
Silver

 053 Blanc  
Blanco  
White

 054 Gris  
Gris  
Grey

 055 Hêtre  
Haya  
Beech

 061 Chêne Moyen  
Roble  
Maple

 062 Poirier  
Peral  
Pear

 116 Wengué  
Wengue  
Wengue

 103 Acacia Clair  
Acacia Clara  
Light Acacia

 104 Acacia Foncé  
Acacia Oscura  
Dark Acacia

 272 Chêne Veiné  
Castaño Claro  
Oak

 273 Chêne Grisé  
Castaño Oscuro  
Dark Oak

# PLANER

Dynamique, flexible et connecté. Le canapé modulaire PLANER s'adapte aux besoins de chaque espace et contribue à la création d'espaces résilients, ouverts et de relax où les réunions informelles peuvent être favorisées dans l'environnement de travail.

Dinámico, flexible y conectado. El sofá modular PLANER se adapta a las necesidades de cada espacio y contribuye a la creación de espacios resilientes, abiertos y de descanso donde fomentar encuentros informales en el entorno de trabajo.

Dynamism, flexibility, and comfort. PLANER modular sofa adapts needs of waiting areas or informal meeting spaces and contributes to a resilient, open, and restful work environment.

CANAPÉS  
MODULABLES

SOFÁ  
MODULAR

MODULAR  
SOFA

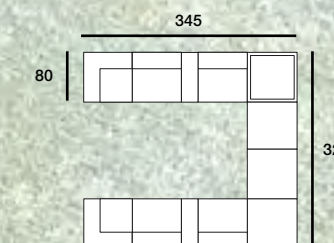

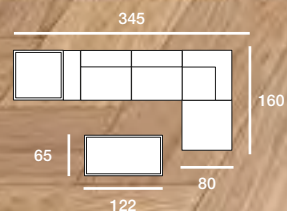



CANAPÉS  
MODULABLES

SOFÁ  
MODULAR

MODULAR  
SOFA



Connexion USB.  
Conexión USB para carga.  
USB charger connected to the electric current.

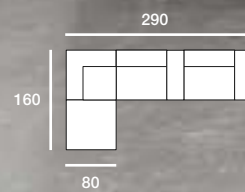

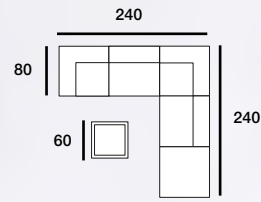

Table basse carrée.  
Mesa de centro cuadrada  
Square coffee table.



Coins en onglet.  
Costura de pestanya.  
Piped seam.



CANAPÉS  
MODULABLES

SOFÁ  
MODULAR

MODULAR  
SOFA

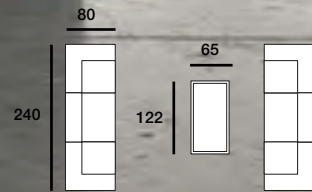





# MODÈLES | VARIANTES | VERSIONS

## MODULES CANAPÉ / MÓDULOS SOFÁ / MODULAR SOFA

MODÈLE / VARIANTES / VERSIONS	DIMENSIONS / MEDIDAS / MEASUREMENTS		RÉFÉRENCE / REFERENCIA / CODE
	Prof./ Depth. 80 cm	L.71 H.80 cm	119.620.000
Individuel d'angle Individual rincón Individual corner			
	Prof./ Depth. 80 cm	L.71 H.80 cm	119.621.000
Terminal droite d'angle Terminal derecho rincón Right corner			
	Prof./ Depth. 80 cm	L.71 H.80 cm	119.622.000
Terminal gauche d'angle Terminal izquierdo rincón Left corner			
	Prof./ Depth. 80 cm	L.71 H.80 cm	119.623.000
Central d'angle Central rincón Add-on corner			
	Prof./ Depth. 80 cm	L.71 H.80 cm	119.610.000
Individuel Individual Individual			
	Prof./ Depth. 80 cm	L.71 H.80 cm	119.611.000
Terminal droite Terminal derecho Right			
	Prof./ Depth. 80 cm	L.71 H.80 cm	119.612.000
Terminal gauche Terminal izquierdo Left			



MODÈLE / VARIANTES / VERSIONS	DIMENSIONS / MEDIDAS / MEASUREMENTS		RÉFÉRENCE / REFERENCIA / CODE
	Prof./ Depth. 80 cm	L.71 H.80 cm	119.613.000
Central Central Add-on			

## MODULES POUF / MÓDULOS PUF / OTTOMAN MODULE



MODÈLE / VARIANTES / VERSIONS	DIMENSIONS / MEDIDAS / MEASUREMENTS		RÉFÉRENCE / REFERENCIA / CODE
	Prof./ Depth. 80 cm	L.71 H.80 cm	119.600.000
Individuel Individual Individual			
	Prof./ Depth. 80 cm	L.71 H.80 cm	119.601.000
Terminal droite Terminal derecho Right			
	Prof./ Depth. 80 cm	L.71 H.80 cm	119.602.000
Terminal gauche Terminal izquierdo Left			
	Prof./ Depth. 80 cm	L.71 H.80 cm	119.603.000
Central Central Add-on			
	Prof./ Depth. 80 cm	L.71 H.80 cm	119.604.000
Individuel petit Individual pequeño Small individual			

## MODÈLES | VARIANTES | VERSIONS

MODULES AUXILIAIRES CONNEXION USB / MÓDULOS AUXILIARES CONEXIÓN USB / AUXILIARY MODULES USB CONNECTION

MODÈLE / VARIANTES / VERSIONS	DIMENSIONS / MEDIDAS / MEASUREMENTS		RÉFÉRENCE / REFERENCIA / CODE
	Prof./ Depth. 80 cm	L.61 H.25 cm	119.634.000
Terminal droite haut Terminal derecho alto High right			
	Prof./ Depth. 80 cm	L.61 H.25 cm	119.635.000
Terminal gauche haut Terminal izquierdo alto High left			
	Prof./ Depth. 80 cm	L.61 H.25 cm	119.636.000
Central haut Central alto High add-on			

MODULES AUXILIAIRES SANS CONNEXION USB / MÓDULOS AUXILIARES SIN CONEXIÓN USB / AUXILIARY MODULES WITHOUT USB CONNECTION

MODÈLE / VARIANTES / VERSIONS	DIMENSIONS / MEDIDAS / MEASUREMENTS		RÉFÉRENCE / REFERENCIA / CODE
	Prof./ Depth. 80 cm	L.61 H.25 cm	119.631.000
Terminal droite haut Terminal derecho alto High right			
	Prof./ Depth. 80 cm	L.61 H.25 cm	119.632.000
Terminal gauche haut Terminal izquierdo alto High left			
	Prof./ Depth. 80 cm	L.61 H.25 cm	119.633.000
Central haut Central alto High add-on			

## FINITIONS | ACABADOS | FINISHES



TISSU AU CHOIX  
TAPIZADO A ELEGIR  
UPHOLSTERED





Cf. page 508  
Ver pagina 508  
See page 508

## MODÈLES | VARIANTES | VERSIONS

MODULES AUXILIAIRES CONNEXION USB / MÓDULOS AUXILIARES CONEXIÓN USB / AUXILIARY MODULES USB CONNECTION

MODÈLE / VARIANTES / VERSIONS	DIMENSIONS / MEDIDAS / MEASUREMENTS		RÉFÉRENCE / REFERENCIA / CODE
	Prof./ Depth. 80 cm	L.39,5 H.25 cm	119.644.000
Terminal droite bas Terminal derecho bajo Low right			
	Prof./ Depth. 80 cm	L.39,5 H.25 cm	119.645.000
Terminal gauche bas Terminal izquierdo bajo Low left			
	Prof./ Depth. 80 cm	L.39,5 H.25 cm	119.646.000
Central bas Central bajo Low add-on			

MODULES AUXILIAIRES SANS CONNEXION USB / MÓDULOS AUXILIARES SIN CONEXIÓN USB / AUXILIARY MODULES WITHOUT USB CONNECTION

MODÈLE / VARIANTES / VERSIONS	DIMENSIONS / MEDIDAS / MEASUREMENTS		RÉFÉRENCE / REFERENCIA / CODE
	Prof./ Depth. 80 cm	L.39,5 H.25 cm	119.641.000
Terminal droite bas Terminal derecho bajo Low right			
	Prof./ Depth. 80 cm	L.39,5 H.25 cm	119.642.000
Terminal gauche bas Terminal izquierdo bajo Low left			
	Prof./ Depth. 80 cm	L.39,5 H.25 cm	119.643.000
Central bas Central bajo Low add-on			



## FINITIONS | ACABADOS | FINISHES

007	Graphite Grafito Graphite	051	Argent Plata Silver	053	Blanc Blanco White	054	Gris Gris Grey	055	Hêtre Haya Beech	061	Chêne Moyen Roble Maple	062	Poirier Peral Pear
116	Wengué Wengue Wengue	103	Acacia Clair Acacia Clara Light Acacia	104	Acacia Foncé Acacia Oscura Dark Acacia	272	Chêne Veiné Castaño Claro Oak	273	Chêne Grisé Castaño Oscuro Dark Oak				



## MODÈLES | VARIANTES | VERSIONS

TABLE BASSES EN TISSU / MESAS TAPIZADAS / UPHOLSTERED TABLES

MODÈLE / VARIANTES / VERSIONS	DIMENSIONS / MEDIDAS / MEASUREMENTS		RÉFÉRENCE / REFERENCIA / CODE
	Prof./ Depth. 80 cm	L.45,5 H.80 cm	119.651.000
Tables pour composition Mesas para composición Table for composition			
 	Prof./ Depth. 65 cm	L.45,5 H.65 cm L.45,5 H.122 cm	119.652.000 119.653.000
Tables basses Mesas de centro Coffe table			

## FINITIONS | ACABADOS | FINISHES

TISSU AU CHOIX  
TAPIZADO A ELEGIR  
UPHOLSTERED

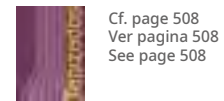

Cf. page 508  
Ver pagina 508  
See page 508



sf

Canapé au design sobre et luxueux aux dimensions généreuses.

Líneas de sofás que abarcan un amplio abanico de posibilidades, en función de su volumen, diseño y calidad.

Sofa to fulfill a wide range of possibilities, given the size, design and quality options.



| CANAPÉS SF1

| SOFÁS SF1

| SF1 SOFAS

| CANAPÉS SF1

| SOFÁS SF1

| SF1 SOFAS



Canapé de dimensions généreuses disponible en fauteuil et canapé deux ou trois places. Il est conçu pour apporter un grand confort aux espaces de travail et de détente.

Sofá de medidas generosas que cuenta con un asiento amplio de una, dos y tres plazas. Diseñados para la comodidad y adaptación en espacios de trabajo.

Executive sofa with wide dimensions of one, two and three seaters. Designed to make more comfortable office workplaces.



| CANAPÉS SF2

| SOFÁS SF2

| SF2 SOFAS

Canapé aux lignes élégantes et fluides, disponible en fauteuil et canapé deux ou trois places.  
Sofás con formas elegantes y rectas de una, dos y tres plazas.  
One, two and three seater sofas with straight and elegant shapes.

| CANAPÉS SF2

| SOFÁS SF2

| SF2 SOFAS

Pieds chromés aux formes modernes.  
Las patas tienen forma triangular y cromadas.  
Triangular chrome legs.



| CANAPÉS SF3

| SOFÁS SF3

| SF3 SOFAS



| CANAPÉS SF3

| SOFÁS SF3

| SF3 SOFAS





Canapé avec un design austère, pratique et de lignes carrées, disponible en une ou deux places.

Sofá de una y dos plazas con un diseño austero y práctico. De forma moderna y sencilla que se adapta a cualquier ambiente.



One and two seater sofas with a stark and useful design.

# MODÈLES | VARIANTES | VERSIONS





## SF1

MODÈLE / VARIANTES / VERSIONS	DIMENSIONS / MEDIDAS / MEASUREMENTS		RÉFÉRENCE / REFERENCIA / CODE
	Prof./ Depth. 96 cm	L.120 H.85 cm	110.612.000
1 place 1 plaza 1 seat			
	Prof./ Depth. 96 cm	L.171 H.85 cm	110.632.000
2 places 2 plazas 2 seater			
	Prof./ Depth. 96 cm	L.228 H.85 cm	110.642.000
3 places 3 plazas 3 seater			

## SF2

MODÈLE / VARIANTES / VERSIONS	DIMENSIONS / MEDIDAS / MEASUREMENTS		RÉFÉRENCE / REFERENCIA / CODE
	Prof./ Depth. 87 cm	L.106 H.73 cm	111.612.000
1 place 1 plaza 1 seat			
	Prof./ Depth. 88 cm	L.157 H.73 cm	111.632.000
2 places 2 plazas 2 seater			
	Prof./ Depth. 88 cm	L.210 H.73 cm	111.642.000
3 places 3 plazas 3 seater			

## SF3

MODÈLE / VARIANTES / VERSIONS	DIMENSIONS / MEDIDAS / MEASUREMENTS		RÉFÉRENCE / REFERENCIA / CODE
	Prof./ Depth. 68,5 cm	L.78 H.79 cm	112.612.000
1 place 1 plaza 1 seat			
	Prof./ Depth. 68,5 cm	L.134 H.79 cm	112.632.000
2 places 2 plazas 2 seater			
	H. 39 cm	65 x 65 cm	112.690.000
		122 x 65 cm	112.680.000
Tables basses Mesas de centro Coffee tables			

## COUSSINS / COJINES / CUSHIONS

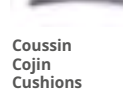
MODÈLE / VARIANTES / VERSIONS	DIMENSIONS / MEDIDAS / MEASUREMENTS		RÉFÉRENCE / REFERENCIA / CODE
	40 x 40 cm		110.050.000
	40 x 25 cm		110.051.000
Coussin Cojín Cushions			

## FINITIONS | ACABADOS | FINISHES

TISSU AU CHOIX  
TAPIZADO A ELEGIR  
UPHOLSTERED

 Cf. page 508  
Ver pagina 508  
See page 508



# MR. JONES

Au design universel italien, les fauteuils et canapés MR.JONES appartiennent à la famille Contract. Les points forts de cette série sont une grande variété de couleurs et de structures qui permettent de répondre à vos besoins les plus exigeants. Les canapés et modules MR.JONES sont ambitieux et confortables.

El diseño italiano es un referente universal. Esta serie forma parte de la familia Contract. El punto fuerte de MR. JONES es la combinación de tapizados para adaptarse al máximo a las opciones que requieran un mobiliario de estas características. MR JONES es nuestro soft seating más atrevido. Su diseño y sistema de módulos no están reñidos con la comodidad.

Italian design is a universal referral. MR. JONES belongs to Contract range. The combination of different fabrics and a wide range of colors are available to reach the most demanding expectation of the customer. MR JONES soft seating is fresh, sassy and very comfortable.

CANAPÉS  
MODULABLES

SOFA  
MODULAR

MODULAR  
SOFA



CANAPÉ  
1 PLACE

SOFA  
1 PLAZA

1 SEAT  
SOFA



Conception innovante et fonctionnelle.  
Un diseño innovador maximizando el  
confort sin abandonar el buen gusto.  
Innovative design with comfort and  
great style.

CANAPÉ 2 PLACES

SOFA 2 PLAZAS

2 SEATER SOFA



Gamme de canapés rembourrés en une ou deux  
teintes différentes dans la même gamme de tissu.  
Se puede tapizar con dos colores distintos de la  
misma serie de tela.  
Can be upholstered with two different colors from  
the same fabric.



FAUTEUIL  
GIRATOIRE

BUTACA  
GIRATORIA

SWIVEL  
ARMCHAIR



Base plate en aluminium poli. Fauteuil pivotant à 360° avec un système de retour automatique.

La base plana es de aluminio pulido con sistema autoretorno y rotación de 360°  
Polished aluminium swivel base have 360° self-rotation system.

## MODÈLES | VARIANTES | VERSIONS

MODÈLE / VARIANTES / VERSIONS	DIMENSIONS / MEDIDAS / MEASUREMENTS	RÉFÉRENCE / REFERENCIA / CODE
 <p>Canapé 1 place Sofa 1 plaza Single seater sofa</p>	Prof./ Depth. 72,5 cm L.83 H.78 cm	163.071.108
 <p>Canapé 2 places Sofa 2 plazas 2 seater sofa</p>	Prof./ Depth. 72,5 cm L.150 H.78 cm	163.070.108
 <p>Modules 1 place Modulos 1 plaza Modular seat</p>	Prof./ Depth. 72 cm L.61 H.78 cm	163.072.108
 <p>Modules 1 place Modulos 1 plaza Modular seat</p>		163.073.108
 <p>Modules angulaires 1 place Modulos angulares Modular angle seat</p>	Prof./ Depth. 80,5 cm L.80,5 H.78 cm	163.074.108
 <p>Modules angulaires 1 place Modulos angulares Modular angle seat</p>		163.076.108
 <p>Module droit 1 place Modulo 1 plaza recto Modular seat (add-on)</p>	Prof./ Depth. 72 cm L.60 H.78 cm	163.075.108

MODÈLE / VARIANTES / VERSIONS	DIMENSIONS / MEDIDAS / MEASUREMENTS	RÉFÉRENCE / REFERENCIA / CODE
 <p>Pouf Pouf Pouf</p>	Prof./ Depth. 51 cm L.77 H.43,5 cm	163.079.108

## FINITIONS | ACABADOS | FINISHES

TISSU AU CHOIX  
TAPIZADO A ELEGIR  
UPHOLSTERED



Cf. page 508  
Ver pagina 508  
See page 508

## MODÈLES | VARIANTES | VERSIONS

MODÈLE / VARIANTES / VERSIONS	DIMENSIONS / MEDIDAS / MEASUREMENTS	RÉFÉRENCE / REFERENCIA / CODE
 <p>Fauteuil giratoire Butaca giratoria Swivel base armchair</p>	Prof./ Depth. 49 cm L.63,5 H.80 cm	163.068.104

## FINITIONS | ACABADOS | FINISHES

BASE  
BASE  
BASE



Aluminium poli  
Aluminio pulido  
Polished aluminium

ASSISE: TISSU AU CHOIX  
ASIENTO: TAPIZADO A ELEGIR  
SEAT: UPHOLSTERED



Cf. page 508  
Ver pagina 508  
See page 508

# NEST

Au design universel italien, les fauteuils NEST appartiennent à la famille Contract. Les points forts de cette série sont une grande variété de couleurs et de structures qui permettent de répondre à vos besoins les plus exigeants. Une conception innovante et confortable sans oublier l'esthétique!

El diseño italiano es un referente universal. Esta serie forma parte de la familia Contract. El punto fuerte de NEST es la combinación de tapizados para adaptarse al máximo a las opciones que requieran un mobiliario de estas características. NEST ayuda que los ambientes sean más acogedores y es una alternativa original a las sillas comunes.

Italian design is a universal referral. NEST belongs to Contract range. The combination of different fabrics and a wide range of colors are available to reach the most demanding expectation of the customer. Create a cozy and friendly room with NEST chair.

FAUTEUIL  
PIÈTEMENT  
TRAÎNEAU

BUTACA CON  
ESTRUCTURA  
PATÍN

SLED FRAME  
ARMCHAIR



| FAUTEUIL  
| PLIANT

| SILLÓN  
| PLEGABLE

| FOLDING  
| ARMCHAIR



Parfait pour être stocké sans perdre de place.  
Ils sont équipés de deux roulettes et deux patins.  
Perfecto para guardarlo sin ocupar espacio.  
It can be stored in tiny corners.

NEST peut être rembourré en une ou deux  
teintes différentes dans la même gamme de  
tissu.  
Se puede tapizar con dos colores distintos de la  
misma tela.  
Can be upholstered with two different colors  
from the same fabric.

| FAUTEUIL FIXE

| SILLÓN FIJO

| FIXED ARMCHAIR





FAUTEUIL  
GIRATOIRE



BUTACA  
GIRATORIA

SWIVEL  
ARMCHAIR



Bases pyramidales ou plates en aluminium poli. Fauteuil pivotant à 360° avec un système de retour automatique.  
Base plana de aluminio pulido con rotación de 360°.  
360° rotation polished aluminium swivel base.



## MODÈLES | VARIANTES | VERSIONS

MODÈLE / VARIANTES / VERSIONS	RÉFÉRENCE / REFERENCIA / CODE
 <p>Fauteuil fixe Sillón fijo Fixed chair</p>	162.060.108
 <p>Fauteuil pliant Sillón plegable Folding chair</p>	162.061.108

## FINITIONS | ACABADOS | FINISHES

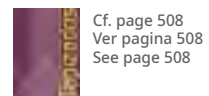
TISSU AU CHOIX  
TAPIZADO A ELEGIR  
UPHOLSTERED



MODÈLE / VARIANTES / VERSIONS	RÉFÉRENCE / REFERENCIA / CODE				
 <p>Fauteuil avec traîneau Butaca con patín Sled frame armchair</p>	162.062.104				
 <p>Fauteuil giratoire avec patins Butaca giratoria con conteras Swivel base armchair</p>	<table border="0"> <tr> <td>Pyramidale / Piramidal / Pyramidal</td> <td>Plate / Plana / Flat</td> </tr> <tr> <td>162.067.104</td> <td>162.068.104</td> </tr> </table>	Pyramidale / Piramidal / Pyramidal	Plate / Plana / Flat	162.067.104	162.068.104
Pyramidale / Piramidal / Pyramidal	Plate / Plana / Flat				
162.067.104	162.068.104				

## FINITIONS | ACABADOS | FINISHES

STRUCTURE  
ESTRUCTURA  
FRAME



BASE  
BASE  
BASE



ASSISE: TISSU AU CHOIX  
ASIENTO: TAPIZADO A ELEGIR  
SEAT: UPHOLSTERED





# RAN

Fauteuil caractérisée par ses formes fluides et légères et par son design intemporel. Un fauteuil qui exalte la créativité, qui permet de créer des espaces de réunion élégants, et qui s'adapte très bien en tant que fauteuil visiteur.

Silla individual caracterizada por sus formas fluidas y ligeras gracias a su diseño atemporal. Su calidad de silla la capacita para crear espacios de reunión elegantes, acompañar como silla confidente y enaltecer la creatividad.

Comfortable and timeless individual chair with an organic shape and a wide selection of upholstery fabrics. Two backrest sizes with moulded foam to achieve comfort and durability that complements practically any interior.



| FAUTEUILS

| SILLONES

| SEATING







Grâce à ses formes et son design élégant,  
le fauteuil RAN assure le meilleur confort.  
Gracias a sus formas y volúmenes el sillón RAN  
te ofrecerá una gran comodidad.  
Chair design offers back support and  
a comfortable feeling.



Avec un design original des accoudoirs.  
Con un diseño de reposabrazos muy original.  
With an original armrest design.





| FAUTEUILS

| SILLONES

| SEATING



## MODÈLES | VARIANTES | VERSIONS

MODÈLE / VARIANTES / VERSIONS	DIMENSIONS / MEDIDAS / MEASUREMENTS		RÉFÉRENCE / REFERENCIA / CODE
 Grand Grande Big	Prof./ Depth. 62 cm	L.69 H.88 cm	1 U. / 1 U. / 1 chairs <b>175.621.100</b>
		L.69 H.88 cm	2 U. / 2 U. / 2 chairs <b>175.622.100</b>
 Petit Pequeño Small	Prof./ Depth. 56 cm	L.57,5 H.79 cm	1 U. / 1 U. / 1 chairs <b>175.611.100</b>
		L.57,5 H.79 cm	2 U. / 2 U. / 2 chairs <b>175.612.100</b>

## FINITIONS | ACABADOS | FINISHES

STRUCTURE  
ESTRUCTURA  
FRAME

 Hêtre  
Haya  
Beech veneer

ASSISE: TISSU AU CHOIX  
ASIENTO: TAPIZADO A ELEGIR  
SEAT: UPHOLSTERED

 Cf. page 508  
Ver pagina 508  
See page 508



# STORN

Grand fauteuil avec une silhouette qui rappelle celle d'un coquillage. Grâce à ses 3 tailles, ce fauteuil s'intègre parfaitement dans une grande variété d'environnements.

Sillón de grandes dimensiones, su silueta nos recuerda a la de una concha de mar. Gracias a sus 3 tamaños, este sillón encaja a la perfección en una gran variedad de ambientes.

Lounge chair Storn, a real eyecatcher, with design and presence which comes in three backrest versions and designed to fit perfectly into a variety of spaces.



Réglage en hauteur  
Regulación altura  
Height adjustment



| FAUTEUILS

| SILLONES

| SEATING





| FAUTEUILS

| SILLONES

| SEATING



Fauteuils avec coussin extra sur l'assise pour un meilleur confort.  
Sillones con cojín extra en el asiento para un mejor confort.  
Lounge chairs with an extra cushion.







Tissu avec zip décoratif.  
Tapizado con cremallera decorativa..  
Upholstered with ornamental zippers.



## MODÈLES | VARIANTES | VERSIONS

MODÈLE / VARIANTES / VERSIONS	DIMENSIONS / MEDIDAS / MEASUREMENTS		RÉFÉRENCE / REFERENCIA / CODE
 <p>Grand Grande Big</p>	Prof./ Depth. 80 cm	L.100 H.100,5 cm	178.122.104
 <p>Moyen Mediano Lounge armchair</p>	Prof./ Depth. 80 cm	L.100 H.88 cm	178.102.104
 <p>Petit Pequeño Small</p>	Prof./ Depth. 72 cm	L.80 H.72 cm	178.112.104

## FINITIONS | ACABADOS | FINISHES

BASE  
BASE  
BASE

Aluminium poli  
Aluminio pulido  
Polished aluminium

ASSISE: TISSU AU CHOIX  
ASIENTO: TAPIZADO A ELEGIR  
SEAT: UPHOLSTERED



Cf. page 508  
Ver pagina 508  
See page 508



# TILOS

La silhouette de ce fauteuil vous invite à vous recueillir et à accueillir le corps. Grâce à son design enveloppant et frais, il peut occuper aussi bien des espaces de rencontre et de collaboration que des espaces de détente et de concentration individuelle.

La silueta de esta butaca invita a recogerse y a acomodar el cuerpo. Gracias a su diseño envolvente y fresco podrá ocupar tanto zonas de reunión y de colaboración como espacios de relax y de concentración individual.

The openness and intimacy of this armchair invites you to sit down and accommodate your body. Lounge chair with an organic shape, various base options, and sizes. For meeting and collaboration areas as well as spaces for relaxation and individual concentration.



Réglage en hauteur  
Regulación altura  
Height adjustment

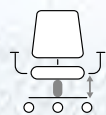

| FAUTEUILS

| SILLONES

| SEATING





| FAUTEUILS | SILLONES | SEATING



Tissu avec zip décoratif.  
Tapizado con cremallera decorativa.  
Upholstered with ornamental zippers.

Réglage en hauteur  
Regulación altura  
Height adjustment

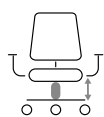









Confort et design au bureau.  
Aporta funcionalidad y diseño en tu oficina  
Round shapes that give a surrounding feeling.

## MODÈLES | VARIANTES | VERSIONS

MODÈLE / VARIANTES / VERSIONS	DIMENSIONS / MEDIDAS / MEASUREMENTS		RÉFÉRENCE / REFERENCIA / CODE
 Fauteuil fixe - Grand Sillón fijo - Grande 4 legs frame - Big	Prof./ Depth. 71 cm	L.79 H.84 cm	1 U. / 1 U. / 1 chairs <b>176.621.100</b>
		L.79 H.84 cm	2 U. / 2 U. / 2 chairs <b>176.622.100</b>
 Fauteuil fixe - Petit Sillón fijo - Pequeño 4 legs frame - Small	Prof./ Depth. 62 cm	L.64 H.80 cm	1 U. / 1 U. / 1 chairs <b>176.611.100</b>
		L.64 H.80 cm	2 U. / 2 U. / 2 chairs <b>176.612.100</b>

 Fauteuil giratoire - Grand Sillón giratorio - Grande Swivel base - Big	Prof./ Depth. 71 cm	L.79 H.96 cm	1 U. / 1 U. / 1 chairs <b>176.121.104</b>
		L.79 H.96 cm	2 U. / 2 U. / 2 chairs <b>176.122.104</b>
 Fauteuil giratoire - Petit Sillón giratorio - Pequeño Swivel base - Small	Prof./ Depth. 62 cm	L.64 H.82 cm	1 U. / 1 U. / 1 chairs <b>176.111.104</b>
		L.64 H.82 cm	2 U. / 2 U. / 2 chairs <b>176.112.104</b>

## FINITIONS | ACABADOS | FINISHES

STRUCTURE  
ESTRUCTURA  
FRAME

 Hêtre  
 Haya  
 Beech veneer

BASE  
BASE  
BASE

 Aluminium poli  
 Aluminio pulido  
 Polished aluminium

ASSISE: TISSU AU CHOIX  
ASIENTO: TAPIZADO A ELEGIR  
SEAT: UPHOLSTERED



Cf. page 508  
Ver pagina 508  
See page 508

# TISSUS TAPIZADOS UPHOLSTERY

Les procédés d'impression ne permettent pas une reproduction exacte des tonalités originales. Pour plus de fiabilité, veuillez consulter le nuancier tissu.

Los procedimientos de impresión no permiten una reproducción exacta de las tonalidades originales. Para una máxima fiabilidad consultar el catálogo de telas.

Printing procedures do not provide an exact reproduction of original colour tones. Please check the fabric sample book.

Série 1 / Serie 1 / Serie 1

ONE



Série 1 / Serie 1 / Serie 1

PUMA



Série 1 / Serie 1 / Serie 1

ARAN



Série 1 / Serie 1 / Serie 1



Série 1 / Serie 1 / Serie 1



Série 1 / Serie 1 / Serie 1



Série 1 / Serie 1 / Serie 1

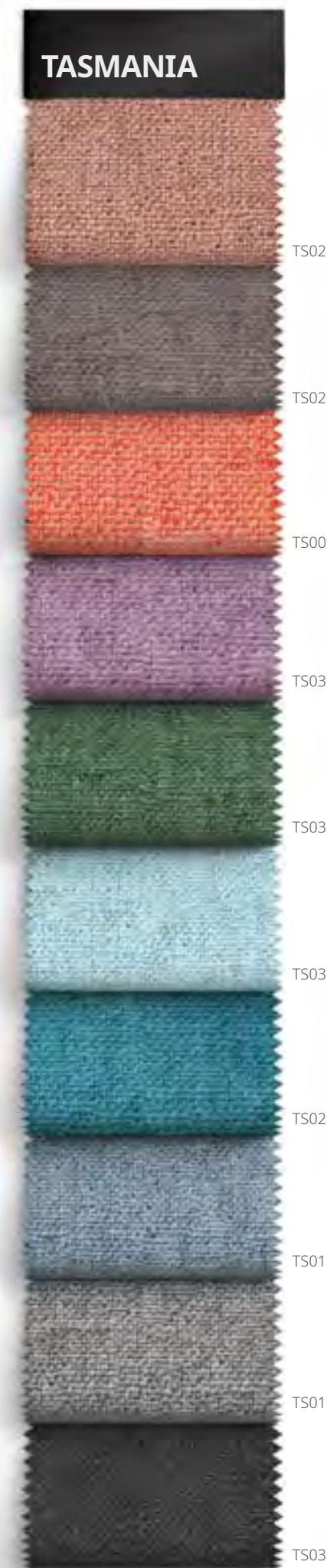

Série 1 / Serie 1 / Serie 1

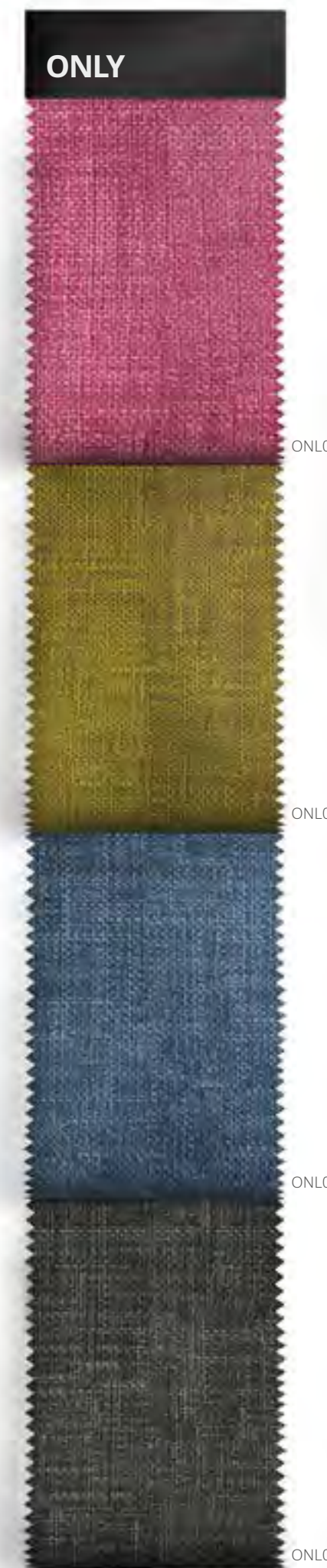

Série 4 / Serie 4 / Serie 4



Série 4 / Serie 4 / Serie 4



**DANZICA**

DA054

DA008

DA063

DA034

DA041

DA046

DA048

DA042

DA064

DA023

Série 4 / Serie 4 / Serie 4



**GRAVITY**

GRA21

GRA12

GRA25

GRA01

GRA28

GRA29

GRA07

GRA17

GRA31

Série 4 / Serie 4 / Serie 4



**RAM**

RAM32

RAM49

RAM34

RAM41

RAM19

RAM75

RAM74

RAM67

RAM03

RAM35

Série 4 / Serie 4 / Serie 4



**SILVERTEX**

S0002

S4024

S0013

S2012

S2064

S5008

S3001

S4001

S4003

S9003

Série 4 / Serie 4 / Serie 4



**EVOLVE**

EVO00

EVO77

EVO21

EVO28

EVO90

Série 7 / Serie 7 / Serie 7



**PIEL**

P.179

P.129

P.102

P.115

P.103

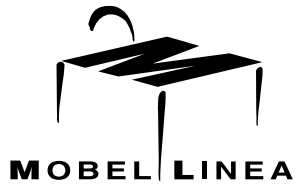

Mobel Linea, S.L. se réserve le droit de modifier les caractéristiques techniques des produits sans préavis en les adaptant au progrès technique. Les procédés d'impression ne permettent pas une reproduction exacte des tonalités originales. Pour plus de fiabilité, veuillez consulter le nuancier finitions. Textes, photos et illustrations non contractuels. / Mobel Linea, S.L. se reserva el derecho a introducir en estos productos sin previo aviso, las mejoras técnicas derivadas de su constante investigación. Los procedimientos de impresión no permiten una reproducción exacta de las tonalidades originales. Para una máxima fiabilidad consultar los catálogos de acabados. / Mobel Linea, S.L. reserves all rights to make technical changes and improvements at any time resulting from his ongoing research, without previous notice. Please bear in mind the actual finish may be slightly different. Since the printing does not show 100% the real colors. To make sure please look at